

BROADCAST NEWS

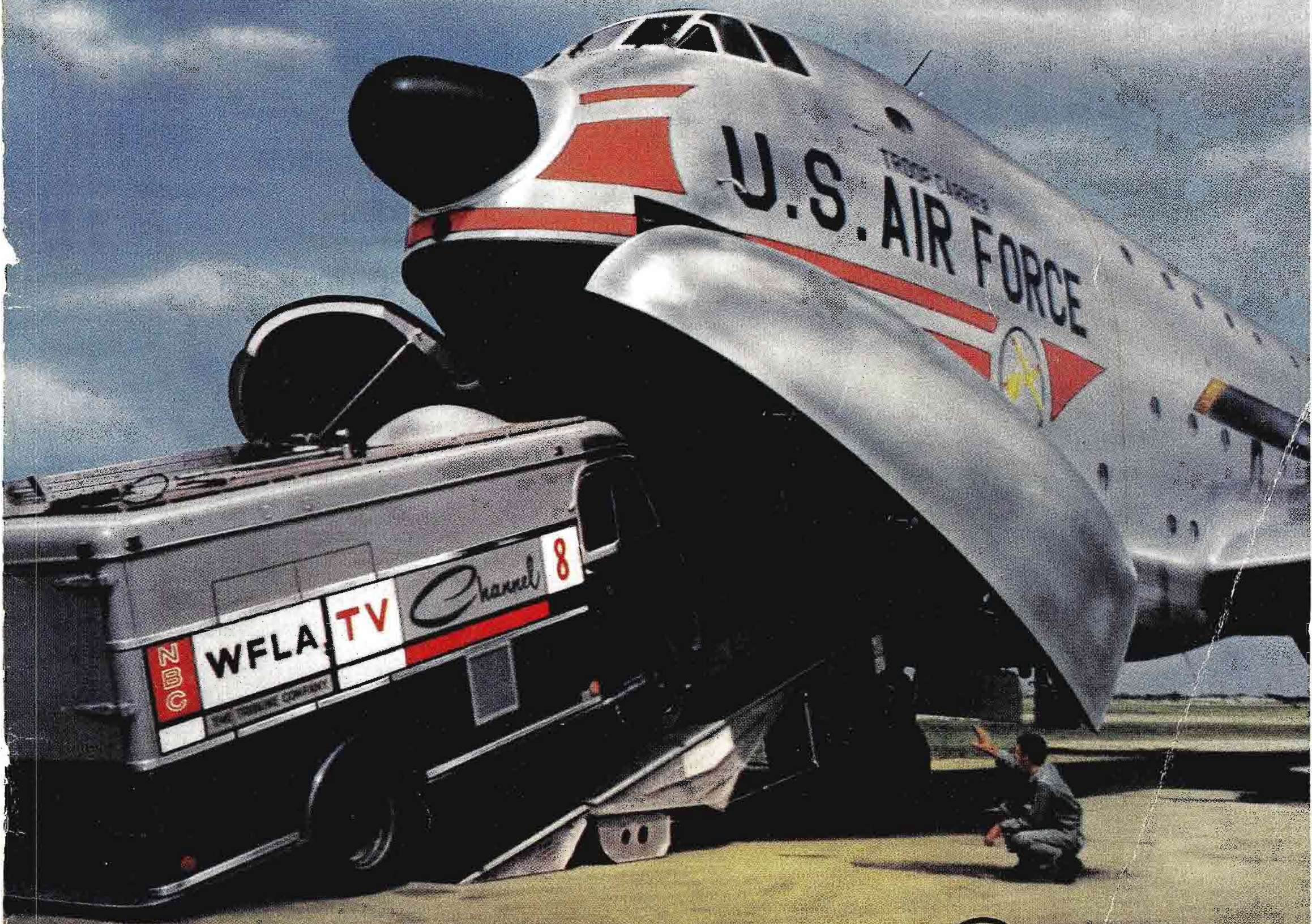

VOL. No. 92 DECEMBER, 1956



Planning a Radio Station ?



***Here's a helpful folder that shows
AT A GLANCE just what you'll need!***
.....

The main equipment items that go into the assembly of a radio broadcast station are represented on this see-at-a-glance "pull-out" display folder. Graphic pictures and descriptions of RCA equipments, with their related system functions, are connected by arrows. The signal path is traced from pickup source to antenna radiation, showing equipment require-

ments at every step. Reduce your station planning to its simplest form with this graphic guide.

Ask your RCA Broadcast Representative to show you this new display folder of Radio Broadcast Equipment (form 3J-2832).



RADIO CORPORATION of AMERICA
Broadcast and Television Equipment Camden, N. J.

Vol. No. 92

December, 1956

BROADCAST NEWS

published by

RADIO CORPORATION OF AMERICA
BROADCAST & TELEVISION EQUIPMENT DEPARTMENT
CAMDEN, NEW JERSEY

PRICE *In continental U.S.A. --- \$4.00 for 12 issues*
In other countries - - - - - \$5.00 for 12 issues

CONTENTS

NEW WMCA STUDIOS TYPIFY TODAY'S RESURGENT RADIO STATION	10
RADIO STATION ON WHEELS	16
NEW RCA CONELRAD RADIO RECEIVER AUTOMATICALLY WARNS OF AIR ALERTS	19
MAKING THE MICROPHONE A MORE VERSATILE ACOUSTIC TOOL	20
A MOBILE TEST AND MEASURING UNIT FOR AUDIENCE RESEARCH	26
HIGHLIGHTS OF HOW NBC COVERED THE 1956 POLITICAL CONVENTIONS	30
WFLA TELEVISION AND RADIO FACILITIES	32
WCAU MODIFIES 3-V SYSTEM FOR LIVE COLOR COMMERCIALS	50
RAI — RADIO TELEVISIONE ITALIANA	56
HOW SK&F USES COLOR TV	64
TV PROJECTION SYSTEM FOR COLOR AND MONOCHROME	72

*Let's
Finish
the Job!*



**Join
THE MARCH
OF DIMES
IN JANUARY**

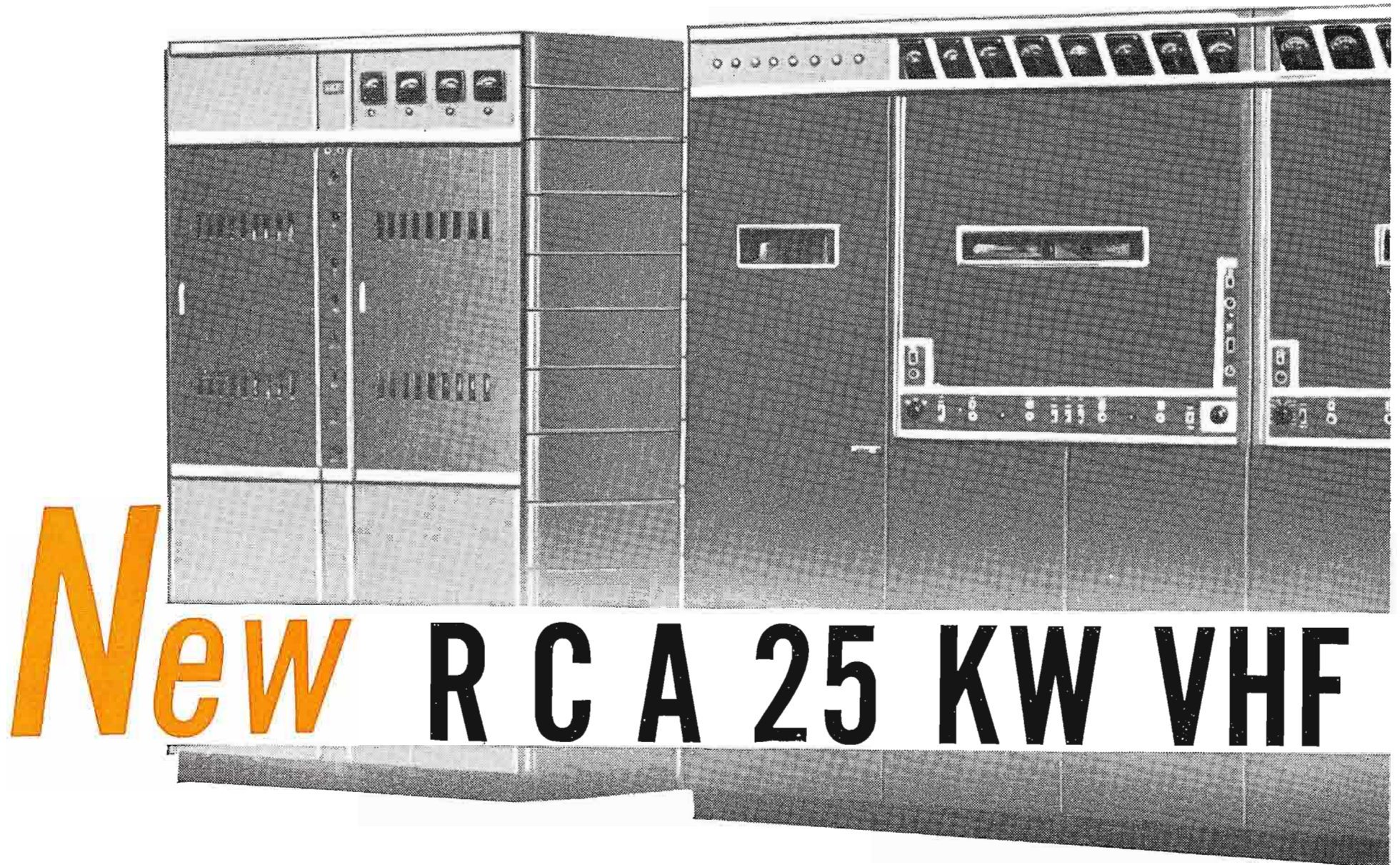

Assures flexible arrangement for economical floor plan

Combining all the newest design features of the recently announced RCA 6 KW TV transmitter and the enviable performance record of RCA's famous 25 KW power amplifiers, the new TT-25CL is today's best value! No other transmitter in this power class embraces so many advantages... advantages that engineers and station managers have asked to have incorporated in a single transmitter.

● **FLEXIBLE FLOOR PLAN**—The "block build" design of the TT-25CL permits several combination arrangements. The layout may be as illustrated in the accompanying floor plan, or a modification of this general plan. The 6 KW Driver and P.A. Rectifier and Control Cabinets can be arranged in "U" fashion with the P.A. tanks moved forward and the driver power supply enclosure placed at a remote location to further conserve space.

● **PRECISE COLOR PERFORMANCE**—Built-in linearity correction circuits and intercarrier frequency control, which accurately maintains frequency separation between aural and visual carriers, assure excellent color signal transmission.

● **EXCELLENT ACCESSIBILITY**—Broadband tuning controls in the 6 KW Driver are accessible without opening any doors. All important driver circuits are adjusted from

the front of the unit. Exciter and modulator units have "tilt-out" construction for quick, complete accessibility.

● **THERMOSTATICALLY CONTROLLED HEATERS**—for rectifier tubes are suited to ambient temperatures as low as 0° C. Designed for attended or remote-control operation.

● **ECONOMICAL OPERATION**—A well-chosen tube complement affords lower power costs. Complete overload protection with "grouped" indicator lights makes troubleshooting quick and certain.

● **TIME-PROVED TUBES**—Long life RCA 5762 tubes in both P.A.'s and Driver. Many broadcasters using other RCA transmitters which employ the 5762 tubes report "extra dividends" due to their long-life, economical operation. Over 100 RCA 25 KW amplifiers have been in continuous service to date—each employs the famous 5762.

PLUS . . . OTHER ADVANCED FEATURES—too numerous to mention here! Get the complete story from your RCA Broadcast Sales Representative or write for descriptive literature (Catalog Bulletin B-4011). In Canada, write RCA VICTOR Company Limited, Montreal.



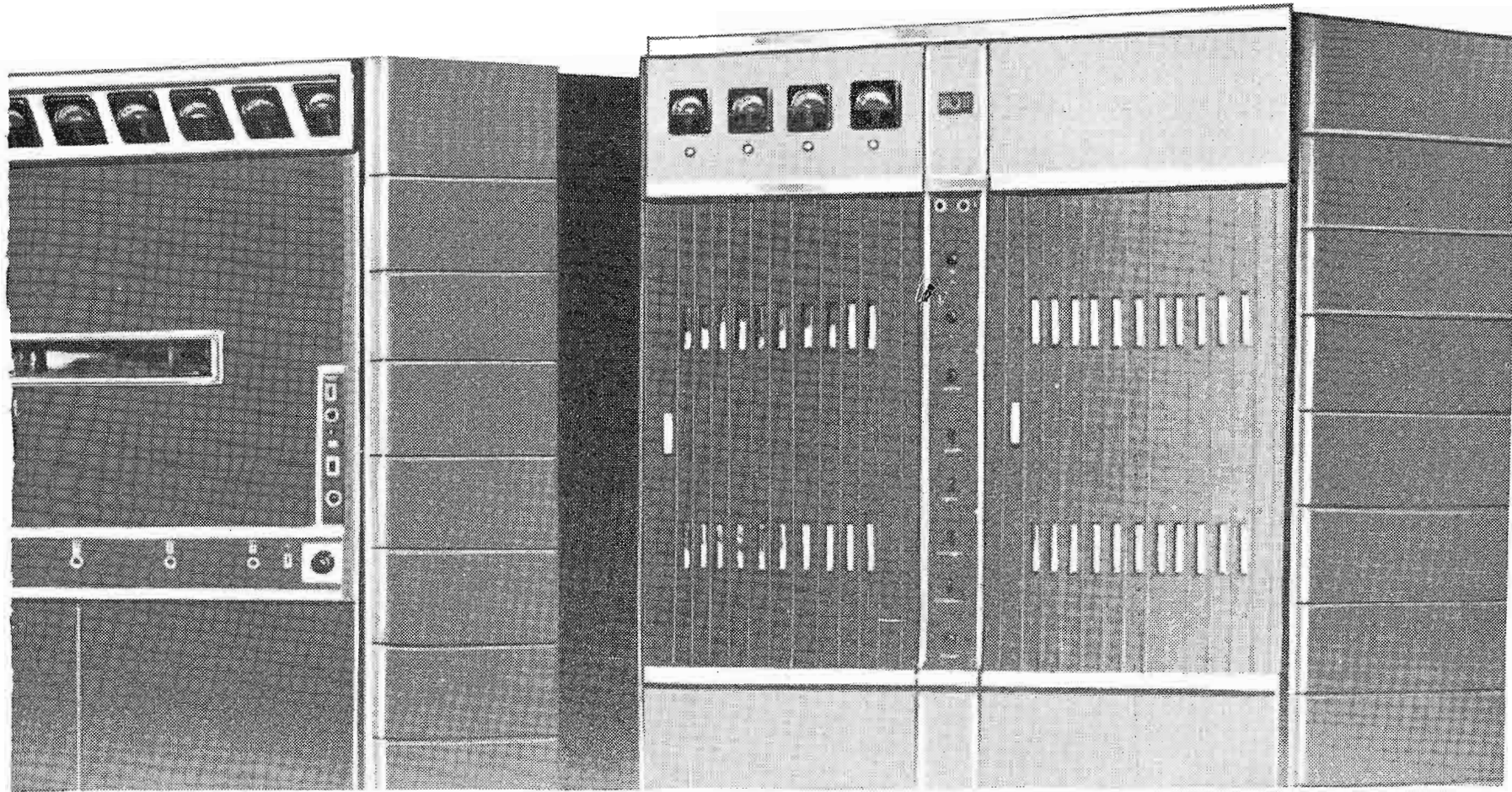

TELEVISION TRANSMITTER

**NOW "ON-AIR"
AT WRGP-TV**

CHATTANOOGA, TENN.

WRGP is receiving excellent reports on transmission since putting the TT-25CL "on-air." Particularly gratifying comments came from color program viewers who are impressed with the fidelity of WRGP color transmission.

(Type TT-25CL, Low Band)

FLOOR PLAN

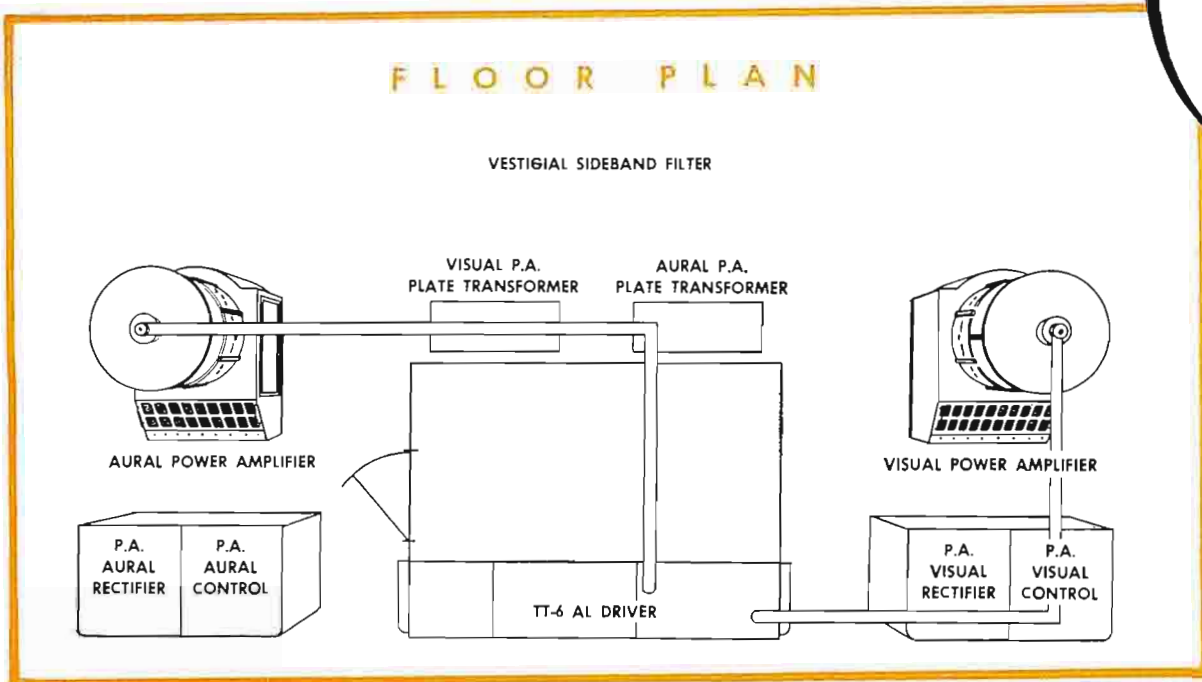

DRIVER PORTION OF THE ABOVE 25 KW TRANSMITTER (LESS AMPLIFIERS) IS AVAILABLE AS A COMPLETE 6 KW TRANSMITTER

Where floor area is at a premium...

such as in "down-town" buildings, or where space must be yielded to other equipment, the TT-25CL is highly adaptable. When new transmitter buildings are contemplated, the space-saving TT-25CL helps to save building costs. The rectifier sections of both the 6 KW Driver and also the Aural and Visual Amplifier Rectifiers can be separated and placed in an adjacent room or basement. This is an added feature that saves valuable operating area.



RADIO CORPORATION of AMERICA

BROADCAST AND TELEVISION EQUIPMENT • CAMDEN, NEW JERSEY

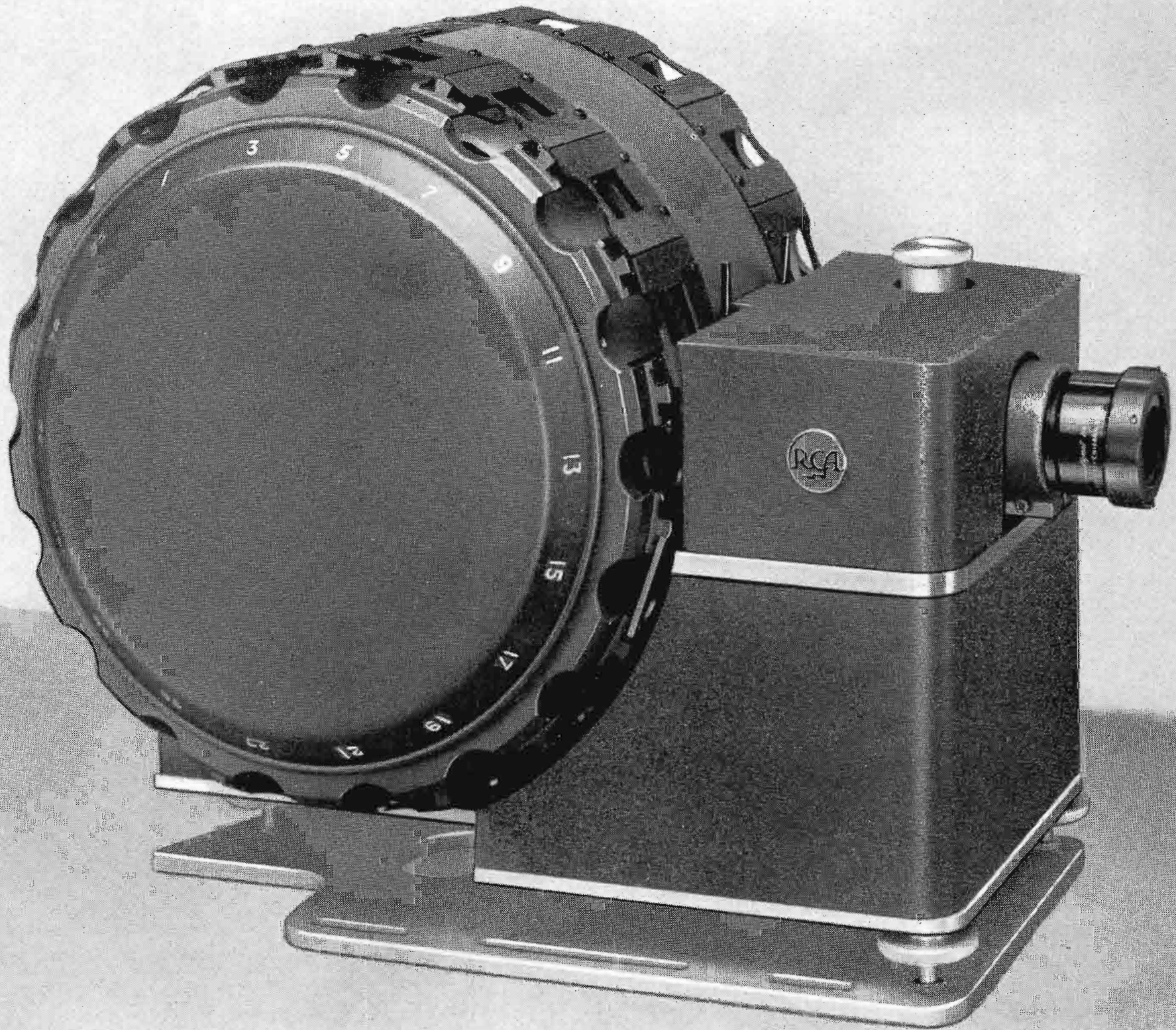

New High-Capacity TP-7 Slide Projector. Dual drums hold a total of 36 slides. For top performance in color and monochrome.

REMARKABLE NEW FEATURES ASSURE

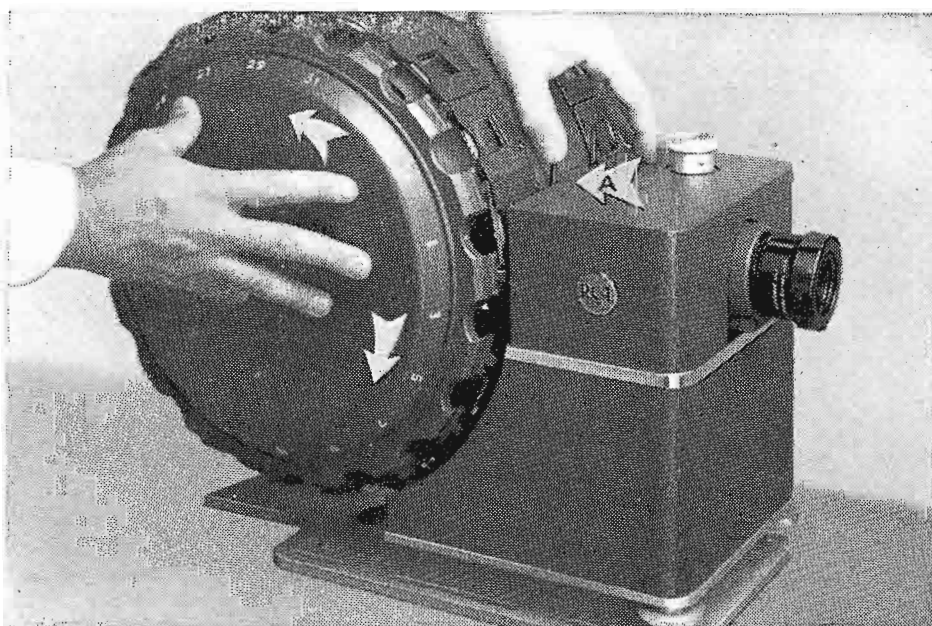

MECHANICAL VERSATILITY

"Free wheeling" principle, with simple lever release (A), permits either drum to be twirled for easy inspection and slide changing. Slides move smoothly and lock securely in show position. Each drum can be operated independently of the other.

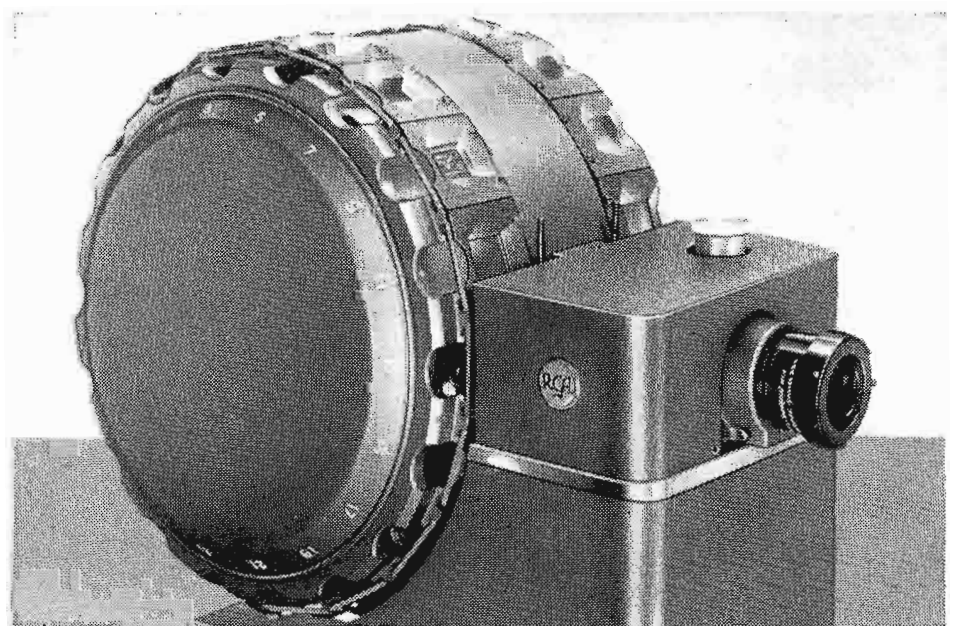

PREVIEW CONVENIENCE

All slides are illuminated for easy viewing making it easy for projectionist to preview them. Last-minute changes can be made before they reach the "show" position.

You told us what you wanted . . . we listened,
designed, field tested . . . with the result:

DESIGNED
THE WAY
YOU WANT IT!

This new professional slide projector excels in performance and operating convenience!

Recognizing the increasing importance of slides in programming at every television station, RCA resolved to do something about the projection equipment.

SURVEY OF USERS—At the outset, a survey was made among users of film-slide equipment to find out what was wanted most.

NEW DESIGN PROJECTOR—The result is a truly professional projector for television use that is exactly tailored to your needs . . . with so many operating advantages it's a pleasure to use! It has an ideal capacity of 36 slides—large enough for handling 99% of all station needs, yet just right for ultra flexibility.

SUCCESSFUL FIELD TEST—The TP-7 Slide Projector has been field tested in actual day-to-day service at a busy television station—WBTV, Charlotte, N.C. So successful was this trial run, the station people did not want to part with the projector when the test was completed!

"OPERATION VIRTUALLY FLAWLESS"—According to Thomas E. Howard, WBTV Vice President and Managing Director of Engineering and General Services, "During the testing period, the TP-7's operation was virtually flawless. An estimated 12,000 slides were run, 170 slides per day on-air, 60 slides in previews and rehearsals."

*Write for illustrated brochure containing complete information
In Canada: RCA VICTOR Company Limited, Montreal.*



RADIO CORPORATION of AMERICA
Broadcast and Television Equipment Camden, N. J.

OPERATIONAL CONVENIENCE AND FLEXIBILITY

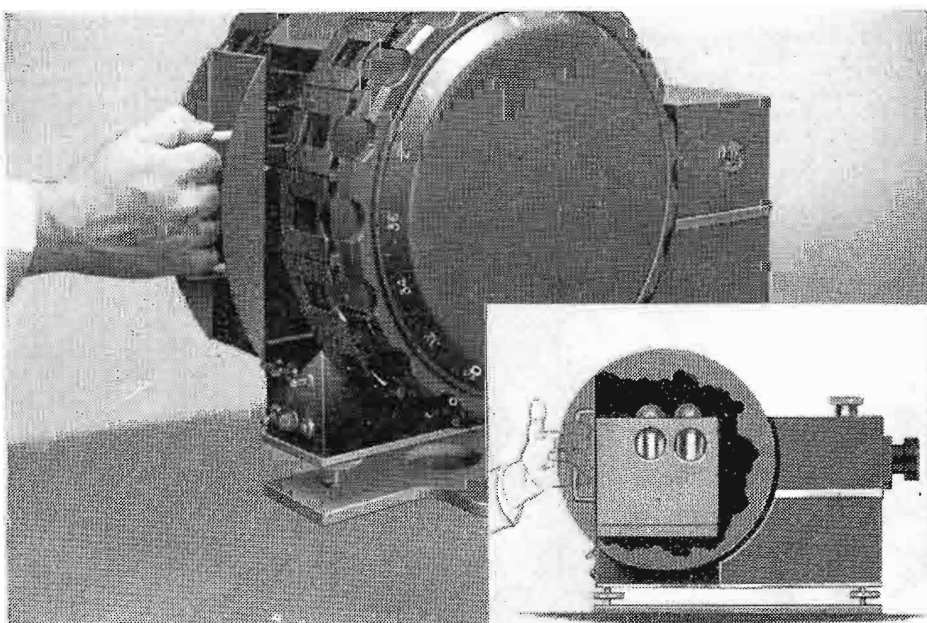

QUICK LAMP CHANGE

Use lamp to failure—reserve lamp instantly slides into place. Highest type optics for uniform brightness over entire field of projected image. One-lamp source eliminates color balance problems.

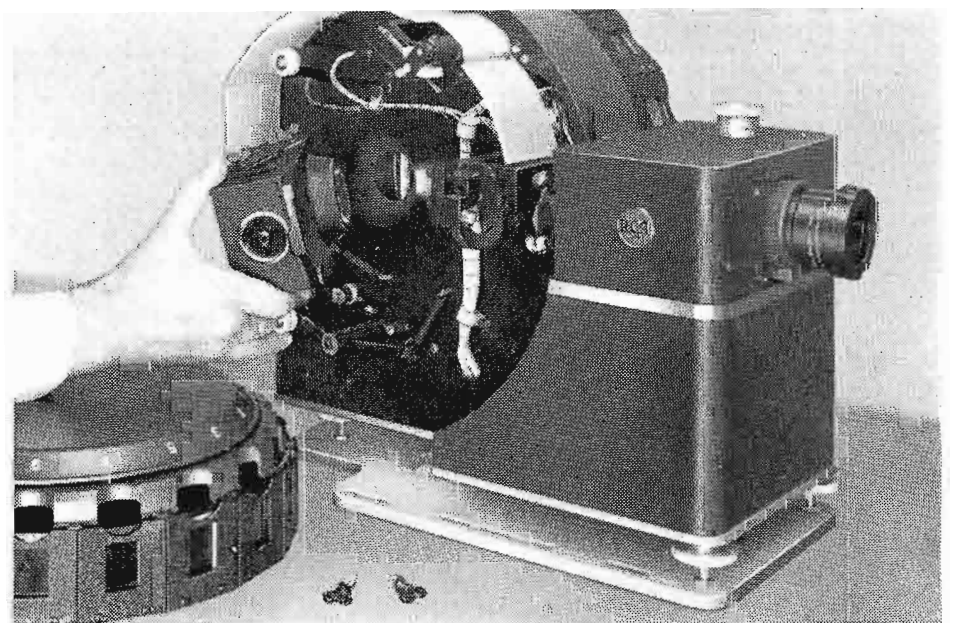

UNITIZED CONSTRUCTION

Designed for ease of operation and servicing. Drums, drum-covers and optical assemblies are easily removed for cleaning and maintenance.

the truth about...

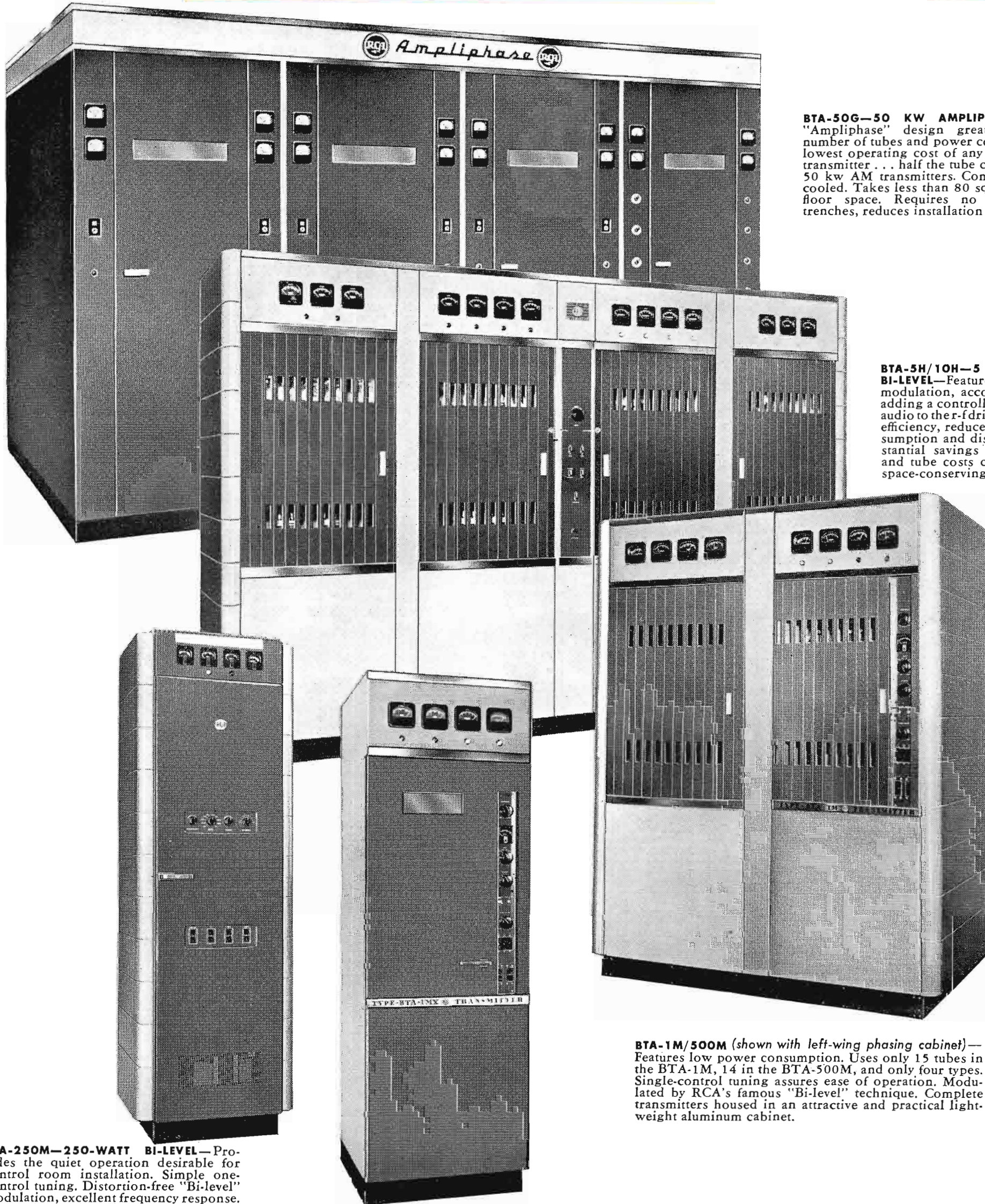

BTA-50G—50 KW AMPLIPHASE—New "Ampliphase" design greatly reduces number of tubes and power costs, assures lowest operating cost of any 50 kw AM transmitter . . . half the tube cost of older 50 kw AM transmitters. Completely air-cooled. Takes less than 80 square feet of floor space. Requires no under-floor trenches, reduces installation costs.

BTA-5H/10H—5 and 10 KW BI-LEVEL—Features "Bi-level" modulation, accomplished by adding a controlled amount of audio to the r-f driver, increases efficiency, reduces power consumption and distortion. Substantial savings in operating and tube costs combine with space-conserving design.

BTA-1M/500M (shown with left-wing phasing cabinet)—Features low power consumption. Uses only 15 tubes in the BTA-1M, 14 in the BTA-500M, and only four types. Single-control tuning assures ease of operation. Modulated by RCA's famous "Bi-level" technique. Complete transmitters housed in an attractive and practical light-weight aluminum cabinet.

BTA-250M—250-WATT BI-LEVEL—Provides the quiet operation desirable for control room installation. Simple one-control tuning. Distortion-free "Bi-level" modulation, excellent frequency response. Uses only 10 tubes of three tube types. An ideal "economy package."

BTA-1MX/500MX—Designed for high-fidelity operation, transmitters BTA-1MX (1KW) and BTA-500MX (500 watts) offer single-control tuning, desirable Bi-level modulation, low power consumption, fewer tubes and fewer tube types. Minimum floor space required . . . approximately 6 square feet.

REMOTE CONTROL EQUIPMENT—RCA Remote Control Equipment provides facilities to switch program lines, adjust plate or filament voltage, operate a line variac control on emergency transmitter, control Conelrad switching, operate power contactors and reset manual overload breakers, from any desired control point, regardless of transmitter design or power.

RCA AM transmitters

FOR 25 YEARS RCA broadcast transmitters have been widely acknowledged as *the* best. During this period they have been the transmitters most often chosen by those stations which wanted, and could afford, the very best. Thus they early became, and have remained, the standard to which all others are compared.

Unfortunately, some stations have believed that they could not afford such quality—no matter how much they wanted it. Today any station can “afford” one of these top-quality transmitters. In fact, it is hard for us to see how a station can afford *not* to buy one.

Why is this so? Simply because today RCA transmitters cost only a very little more than the lowest-priced (sometimes no more). And the small extra original cost (if any) is more than made up for by these two *facts*:

- 1. RCA transmitters are generally less expensive to operate.** This is so because in almost every power class RCA transmitters either use less power, or have lower tube cost (in some cases both).
- 2. RCA transmitters almost always have higher resale value.** This becomes very important when you go to higher power, or if you should decide to sell your station.

What is the moral? Simply this: don't jump to the conclusion you can't afford RCA. We believe you can, and we would like an opportunity to prove it. Call our nearest *AM Specialist* (see list). He will be glad to go over your situation with you, give you the benefit of his (and RCA's) broadcast equipment knowledge, and leave with you a complete and fair proposition. With such *facts* at hand you can make a correct decision. There's absolutely no obligation. You owe it to your station to find out. Act now!

See Your Nearest
Radio Broadcast Sales
Representative

- ATLANTA 3, GA.**
522 Forsyth Bldg., Lamar 7703
- BOSTON 16, MASS.**
200 Berkeley Street, Hubbard 2-1700
- CAMDEN 2, N.J.**
Front & Cooper Streets,
Woodlawn 3-8000
- CHICAGO 54, III.**
Delaware 7-0700 Merchandise
Mart Plaza, Room 1186
- CLEVELAND 15, OHIO**
1600 Keith Bldg., Cherry 1-3450
- DALLAS 1, TEXAS**
1907-11 McKinney Avenue,
Riverside 1371
- DAYTON 2, OHIO**
120 West Second Street,
Hemlock 5585
- HOLLYWOOD 28, CALIF.**
1560 N. Vine Street,
Hollywood 9-2154
- KANSAS CITY 6, MO.**
1006 Grand Avenue, Harrison 6480
- NEW YORK 20, N.Y.**
36 W. 49th Street, Judson 6-3800
- SAN FRANCISCO 2, CALIF.**
420 Taylor Street, Ordway 3-8027
- SEATTLE 4, WASHINGTON**
2250 First Avenue, South, Main 8350
- WASHINGTON 6, D.C.**
1625 K Street, N.W., District 7-1260

Typical AM Tower



RADIO CORPORATION of AMERICA
BROADCAST AND TELEVISION EQUIPMENT
CAMDEN, N. J.

RCA INTRODUCES A COMPLETELY

"FAMILY" OF AUDIO

A model to "fit" every station requirement...

ALL HAVE "BUILT-IN" POWER SUPPLIES, MONITORING AMPLIFIERS AND SPEAKER RELAYS

Here is a "family" of three consolettes that give you the widest choice of facilities ever offered. All have printed-wiring amplifiers in modular construction, providing the utmost in circuit uniformity and performance. Each model has its own "built-in" power supply (the BC-6A has two). Each has built-in monitoring amplifiers and speaker relays.

INSTALLATION IS QUICK, EASY...INEXPENSIVE

The "self-contained" feature of all three models makes them easy to install. There is no need for costly external wiring and "hunting" for a place to mount such items as power supplies, monitoring amplifiers and speaker relays. The reduction of external wiring minimizes the chance of stray hum pick-up greatly improving system performance.

CONVENIENT OPERATION

The low height of each consolette affords maximum studio visibility... no stretching to observe cues. Relaxed wrist comfort is provided by mixer controls on the right slant... at the right position above the desk top. RCA-developed

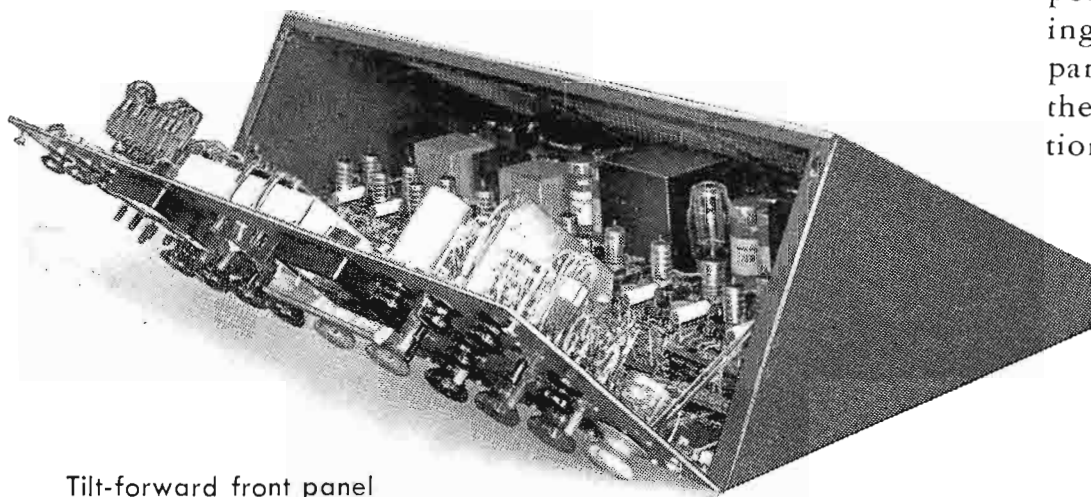

Tilt-forward front panel permits quick accessibility to mixer pads and spring contacts; makes maintenance easy.

finger-grip knobs provide convenient, positive control and are color coded for "function identity."

EASE OF MAINTENANCE

Routine maintenance time is reduced by the quick accessibility of all components... easy-to-clean mixer pads, simple-to-adjust leaf-spring contacts on key and push-button switches. This is achieved by a snap-off top cover and a tilt-forward front panel, in addition to strategic placement of components.

RCA MATCHED STYLING PERMITS EXPANDABILITY

Styled with 30-degree sloping panels which match previous equipments such as the BC-2B consolette, BCM-1A mixer, and compatible among themselves, a wide range of augmented facilities is possible. Paired BC-5As provide dual channel operation and extended facilities. Addition of the BCM-1A mixer to any of these consolettes is simple and provides added microphone inputs.

THEY WORK WELL INTO CUSTOM ARRANGEMENTS

Simple functional design and "engineered" compactness makes any number of custom installation arrangements possible. A custom "U" arrangement of two BC-5As flanking a BCM-1A mixer is possible. The 30-degree front panels match the slope of video control equipment making them suitable for use in television studio custom applications as well as in radio.

*Ask your RCA Broadcast Sales Representative
for detailed information*



RADIO CORPORATION of AMERICA

BROADCAST AND TELEVISION EQUIPMENT • CAMDEN, N. J.

NEW

CONSOLETTES



BC-5A NINE INPUTS

—facilities for 4 microphones, 2 turntables, 2 remote lines, 1 network or tape. 4 mixer positions. *Built-in power supply.* Easily expanded for dual channel use by "pairing." Block building lends "custom touch" when paired with existing BC-2B's.....

\$875*



BC-3B THIRTEEN INPUTS

—facilities for 6 microphones, 2 turntables, 2 remote lines, 1 network, 2 utility inputs which may be used for additional turntables, tape, or as required. Eight mixer positions. *Built-in power supply.* Easily expanded for dual channel use by pairing with BC-5A. Convenient script rack.

\$1095*

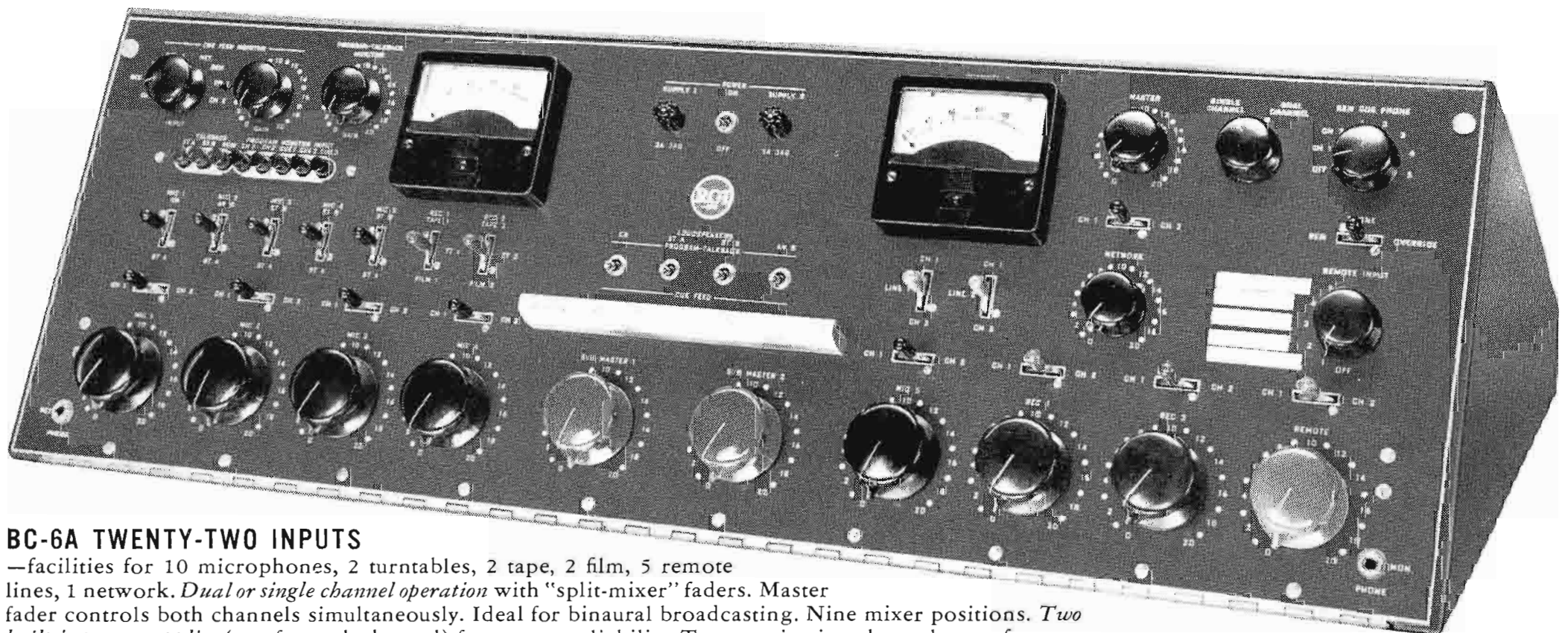

BC-6A TWENTY-TWO INPUTS

—facilities for 10 microphones, 2 turntables, 2 tape, 2 film, 5 remote lines, 1 network. *Dual or single channel operation* with "split-mixer" faders. Master fader controls both channels simultaneously. Ideal for binaural broadcasting. Nine mixer positions. *Two built-in power supplies* (one for each channel) for greater reliability. Two monitoring channels, one for program monitoring and talkback, one for cueing and feeding background to studios. Convenient script rack.

\$1750*

**Less Tubes—Prices subject to change without notice.*

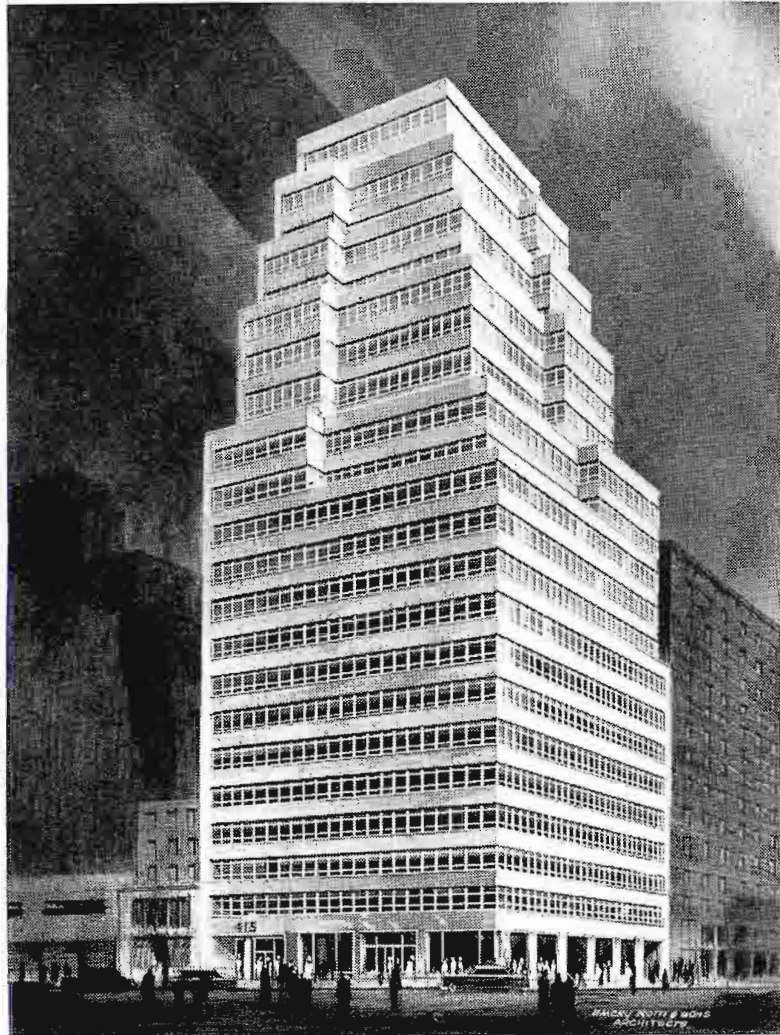

NEW WMCA STUDIOS TYPIFY TODAY'S RESURGENT RADIO STATION

Studio and Technical Facilities Planning Reflect Radio Programming Changes in Last Decade. Custom-Built Type of Installation Achieved Using Stock RCA Equipment

FIG. 1. WMCA's new studios occupy the entire 13th floor of this modern office building.

New York City's newest radio studios and offices are those of station WMCA, in a newly-constructed office building at 415 Madison Avenue. This is located in the heart of New York's advertising agency district and makes possible on-the-spot service to WMCA's many accounts.

Planning for the new studios was begun before the brand-new structure reached the construction stage, thus permitting the maximum of co-ordination between the building architects, the builders and the WMCA planning staff.

Before actual layout work began, considerable time was devoted to a study of the changes which have occurred in radio programming techniques and requirements in the last decade. There is less need for auditorium-type studios, instead the emphasis has shifted to smaller studios. The great increase in the popularity of disc-jockey and other recorded-music programs has been reflected in the planning of the technical facilities as well as the studios themselves. Considerable study went into the planning so as to provide for efficient, smooth operation. The equipment was selected and installed to offer the operating engineer maximum flexibility combined with ease of operation.

Under the supervision of General Manager M. M. Fleischl, the actual layout was the work of James McCafferty, Technical

Supervisor, and Ruth Musser, Office and Personnel Manager. The floor plan is illustrated in Fig. 3. Although a number of minor changes were necessitated by the requirements of the architects the end result is a completely co-ordinated, effective radio operation serving the requirements of the nation's largest city and the more than five million radio homes in the WMCA service area.

Studio Design

The three studios are located so as to permit easy access from one to the other and to the associated control rooms. The use of a single sound lock common to each of the studios kept floor space requirements within the available limits, and at the same time keeps the time required to move from one studio to another at a minimum. Excellent acoustical properties in each of the studios were achieved by proper proportioning of room dimensions and by the extensive use of acoustic material.

Although the entire building is air-conditioned, an independent air-conditioning installation cools the studio spaces. This increases the comfort of station personnel on all-night shows and on weekends when the main building units have been shut down. In addition, a possible source of outside noise is eliminated which might otherwise be brought in by the ductwork.

Although separate control facilities are provided for each studio, each control position is equipped with identical basic components arranged in the same manner. This permits the studio engineers to become accustomed to a standard operating procedure, and allows them to move from one control room to another without the need for re-orientation.

Studio Equipment

Studio "A", which is shown in the photograph (Fig. 4) and in the floor plan is the largest of the three studios, measuring 22 by 32 feet. This studio is used primarily for larger gatherings, or when the performers must move about with complete freedom. Studio "A" was intended for the production of dramatic or musical "live-talent" shows, but it also finds use in rehearsals, recording and for occasional "disc-jockey" operation. Adjacent to Studio "A", and accessible to it through a door, is a small area designed for use as an echo chamber.

The control room associated with this studio provides more than adequate working space for the control engineer, a director, a producer and such other personnel or guests as may wish to observe the program in progress. Control facilities are grouped at the end of the room (as shown in Fig. 5), permitting the engineer complete freedom without restricting the move-

studios. Thus it is possible for the engineer to transfer to the other studio for a short announcement or a station break without requiring the presence of a second engineer at the other control position. Two engineers are used, of course, for anything more extensive than a short announcement, or when two programs are originating simultaneously (as for recording).

Third Turntable Improves Operation

Control equipment for Studios "B" and "C" is similar to that of Studio "A" control, except that the consolettes are not called upon to control as many microphones (simultaneously) as in the case of the larger studio. Details of the physical arrangement of the equipment are shown in Figs. 7 and 8. It will be noted that two

turntables are located at the operator's left and a third turntable and a tape recorder are to his right. The availability of the third turntable is credited with much of the smoothness which characterizes operations at WMCA.

The two left-hand turntables are used primarily for musical recordings. The third turntable can thus be employed almost exclusively for commercials, record jingles, or effects, in addition to themes. By permitting the operating engineer greater freedom, last-second, hasty "cueing" is avoided. This also reduces the possibility of human error. According to Mr. McCafferty, the Technical Supervisor, the operators have expressed themselves as reluctant to consider returning to the old two-table operating system.

Although it is a station policy to originate most shows "live", WMCA makes considerable use of tape recordings. Disc jockeys customarily pre-record the spoken portions of their programs before taking a day off, thus permitting the well-known station personalities to be featured on a seven-day basis. Tape recordings are also used for commercial spots, or for agency "air checks".

An area to the rear of the Studio "C" Control Room has been set aside as a working space and for tube and parts storage. Immediately adjacent to this area, and visible in Fig. 9, is the station's disc-recording installation. This consists of a pair of RCA Type 73-C disc recorders, together with associated play-back, vacuum and other equipment.

Saving Rack Space

Figure 10 shows the two rack cabinets which house the amplifiers, line terminating and switching equipment, AM-FM monitor receiver, equalizers and other equipment. Here WMCA has received the benefit of "custom" equipment which was assembled from stock RCA catalog items.

In the left-hand rack are two Type BR-22A panels and shelves which contain a total of ten amplifiers, all of which are Type BA-23A, the new RCA "etched-wiring" type. The small physical size of these amplifiers has resulted in a noticeable saving in rack space, yet they perform as well as or better than earlier models more than twice their size. Also visible are the four VU-meters, normally connected to each of the four outgoing lines.

Custom Effect from Stock Components

The engineering staff of WMCA has achieved a completely integrated, smooth-

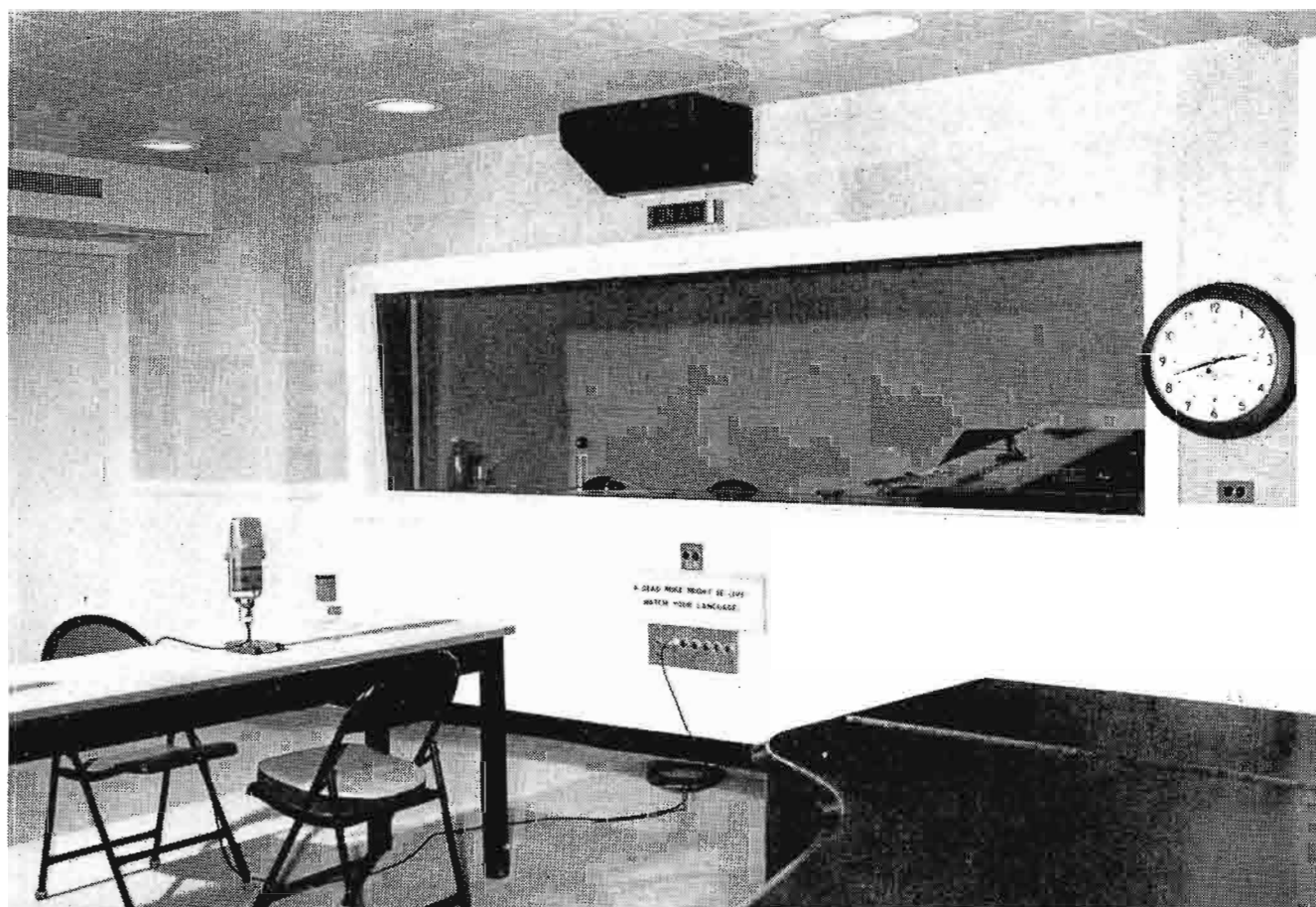

FIG. 4. Microphone warning lights tell the announcer when his mike is "hot". The "On Air" signs indicate only that the studio is in use. The red warning lights, shown just above the sign and microphone receptacles, are used in a parallel hook-up to protect against possible burn out.

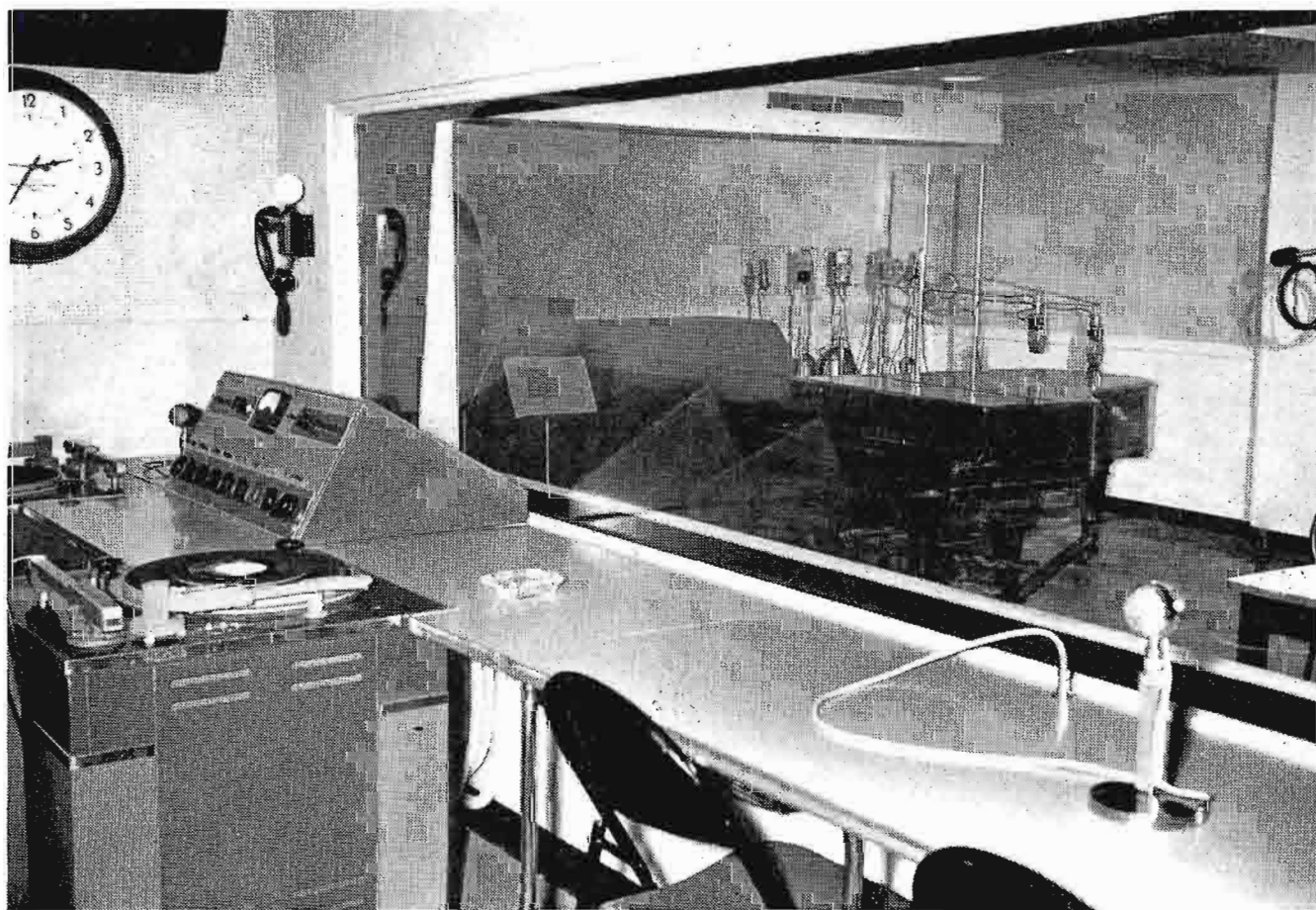

FIG. 5. Studio "A" control room has control facilities located at one end of the room in order to minimize the possibility of interference with the operating engineer.

operating studio control "package" which gives the station a "custom-built" installation assembled from stock RCA equipment. Only such things as the engraved panels for the four VU meters and the line equalizers were especially prepared, and these items may be fabricated by almost any well-equipped machine shop. In the main, the modifications to the stock components were made in order to make the unit fit more directly into WMCA's operational pattern.

Trouble-Free Operation

Inasmuch as WMCA is on the air seven days per week and twenty-four hours per day, considerable thought was given to planning for trouble-free operation for years to come. Although maintenance personnel are immediately available to correct troubles occurring during the day, it was felt that certain precautions were indicated should a tube or component fail in service over a weekend or in the middle of the night.

One of the primary results of this foresighted plan was the "cross-connection" of the consolettes which serve Studios "B" and "C". In case a difficulty should arise in one of the consolettes, the operation can be shifted to the other operating point. As a double safety-check feature, dual power supplies were installed for each consolette, together with a manual transfer switch permitting instant change-over. These were mounted on the wall rather than below the consolette table, thus making them more readily accessible for either the change-over or for maintenance.

Also worthy of note is the use of three turntables at each operating position. Although this was done to improve operation rather than as a safety measure, the station personnel agree that the presence of the extra table would be of great value should one of the pickups, a turntable motor, or an amplifier tube give trouble. "Even the best of equipment has an eventual life-expectancy beyond which troubles are bound to develop," says Mr. McCafferty, the Technical Supervisor. "We considered the fact that WMCA will be using this equipment many years from now, and planned as much as possible for the future as well as for the present."

Creative Engineering

WMCA's engineers have developed and installed a number of noteworthy innovations. For example, visiting engineers or guests are often asked if they can find the talk-back microphones, as they look at "B" and "C" control desks. After much searching, those who are familiar with the

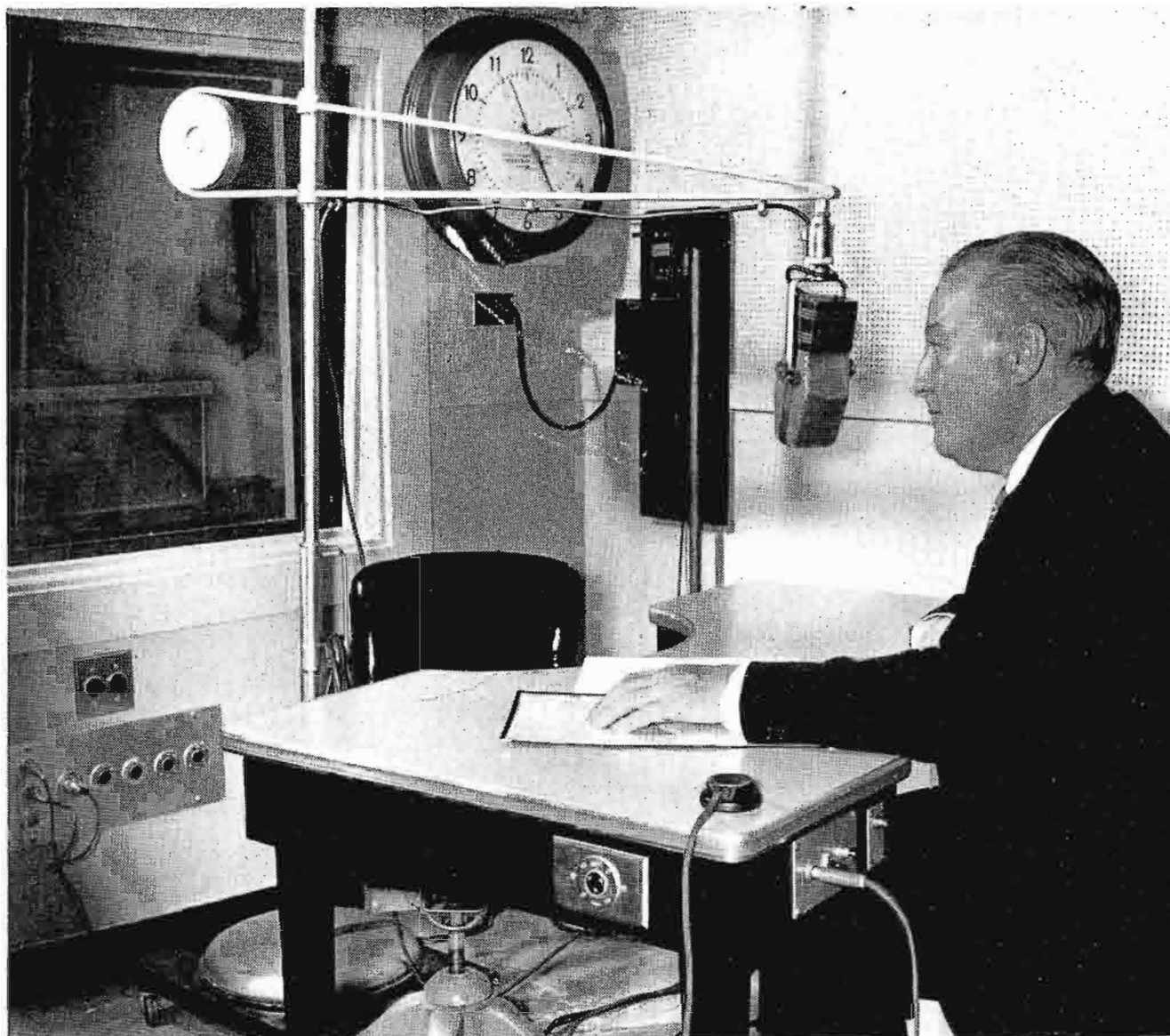

FIG. 6. Shown in Studio "C" are the specially-constructed table, time-signal chime and microphone warning lights. Controls for the talk-back circuit, head phone jack and push-button for time signal are visible on the edge of the table.

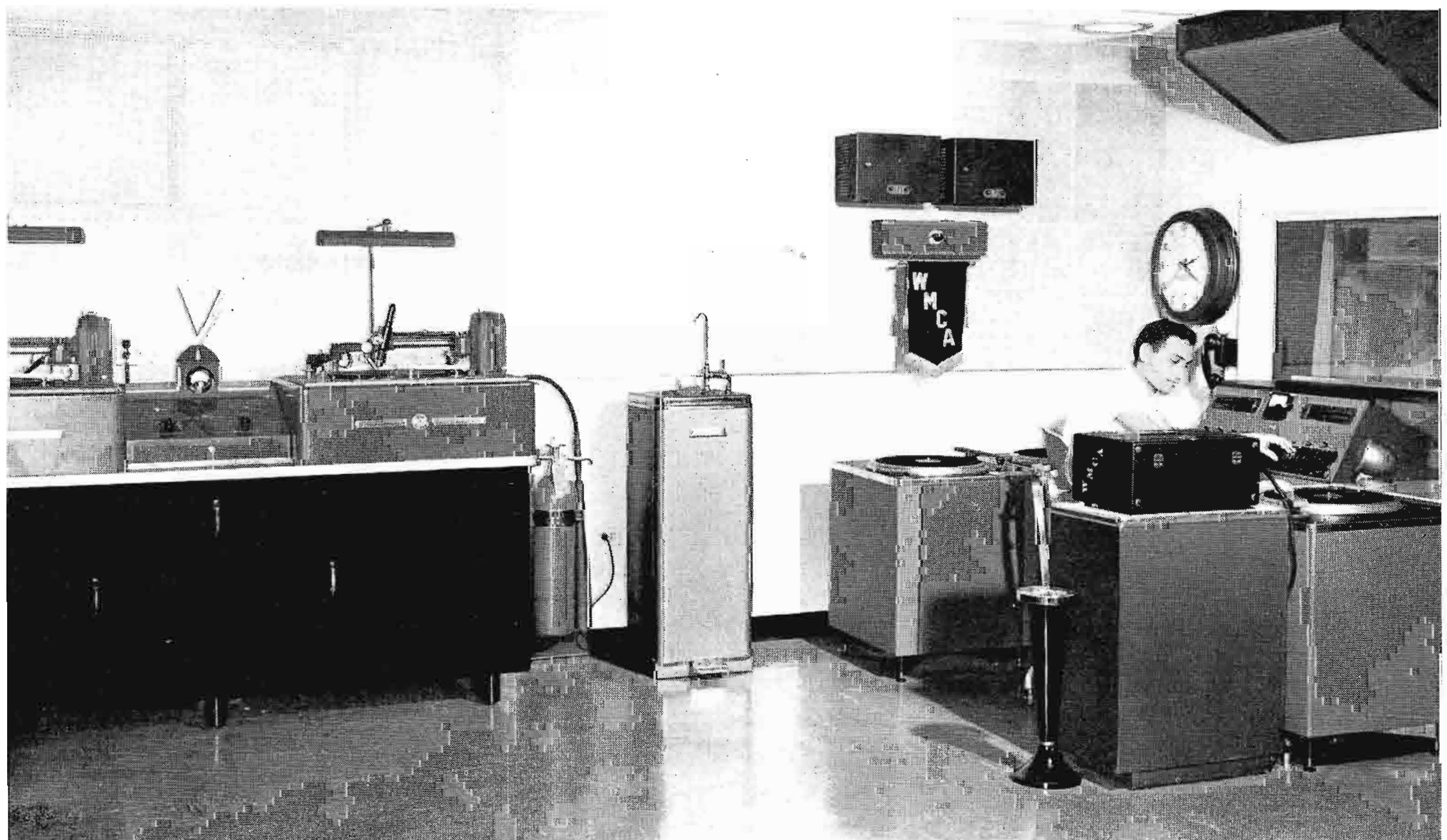

FIG. 7. Studio "B" control room is typical of the facilities available in the other two control rooms and contains a BC-2B Studio Consolette, three BQ-2A turntables, tape recording equipment and LC-1A monitor loudspeakers.



FIG. 8. Availability of a third turntable in each control room is responsible for much of the smoothness of WMCA operations. Control room for Studio "A" with three Type 70-D turntables is shown.

FIG. 9. A pair of Type 73-C disc recorders are located next to the Studio "C" control room.



normal appearance of the RCA BC-2B consolette may notice a number of small holes in a plug (filling a hole normally used for warning or indicator lights) to the left of the VU meter. Behind this plug has been installed the mechanism of an RCA Aerodynamic microphone. The microphone is thus out of the way of the operator but is readily available to him.

Behind each consolette in "B" and "C" control room areas a simple shelf or table has been placed. The shelf consists of a pair of chrome-plated legs and a plywood-and-metal top. The legs, attached to the rear of the shelf, rest on the table which supports the BC-2B consolette, while the front of the shelf is supported by the top of the consolette itself. This arrangement provides a level surface on which records, transcriptions and the like may be placed—yet it does not interfere with the ventilation louvers in the top of the consolette.

A relatively simple modification of the BC-2B Consolette in the Studio "A" control room adds to the versatility of the unit by permitting simultaneous use of up to six microphones in the large studio during "live" shows without the need for a patch board. In normal use, the consolette is wired for up to four microphones (the first four faders), three turntables (the next three faders) and a tape recorder. The fifth and sixth inputs are transferred from turntables to microphone use by the operation of a pair of telephone-type "twist" key switches, which are mounted in the two holes on each side of the VU meter. The tape recorder playback is brought into the unit through one of the "remote line" input push-buttons.

WMCA uses separate amplifiers and speakers for record cueing, thereby permitting the output level of the cue amplifier to be adjusted to the desired point without affecting the program monitor level. The use of cue-type controls in the BC-2B eliminates the need for a separate switching operation by the engineer when cueing a record.

WMCA has been occupying the new studios and office for eight months, long enough for the station personnel to accustom themselves to the new surroundings and to evaluate the results of the extensive planning which went into the move from the former studios at 1657 Broadway. It is the accepted opinion of the staffers that the new installation is precisely suited to the needs of radio programming in the highly-competitive New York market. The new studios and facilities are typical of their continuing drive to provide top entertainment for their listeners and the best of service to their advertisers.

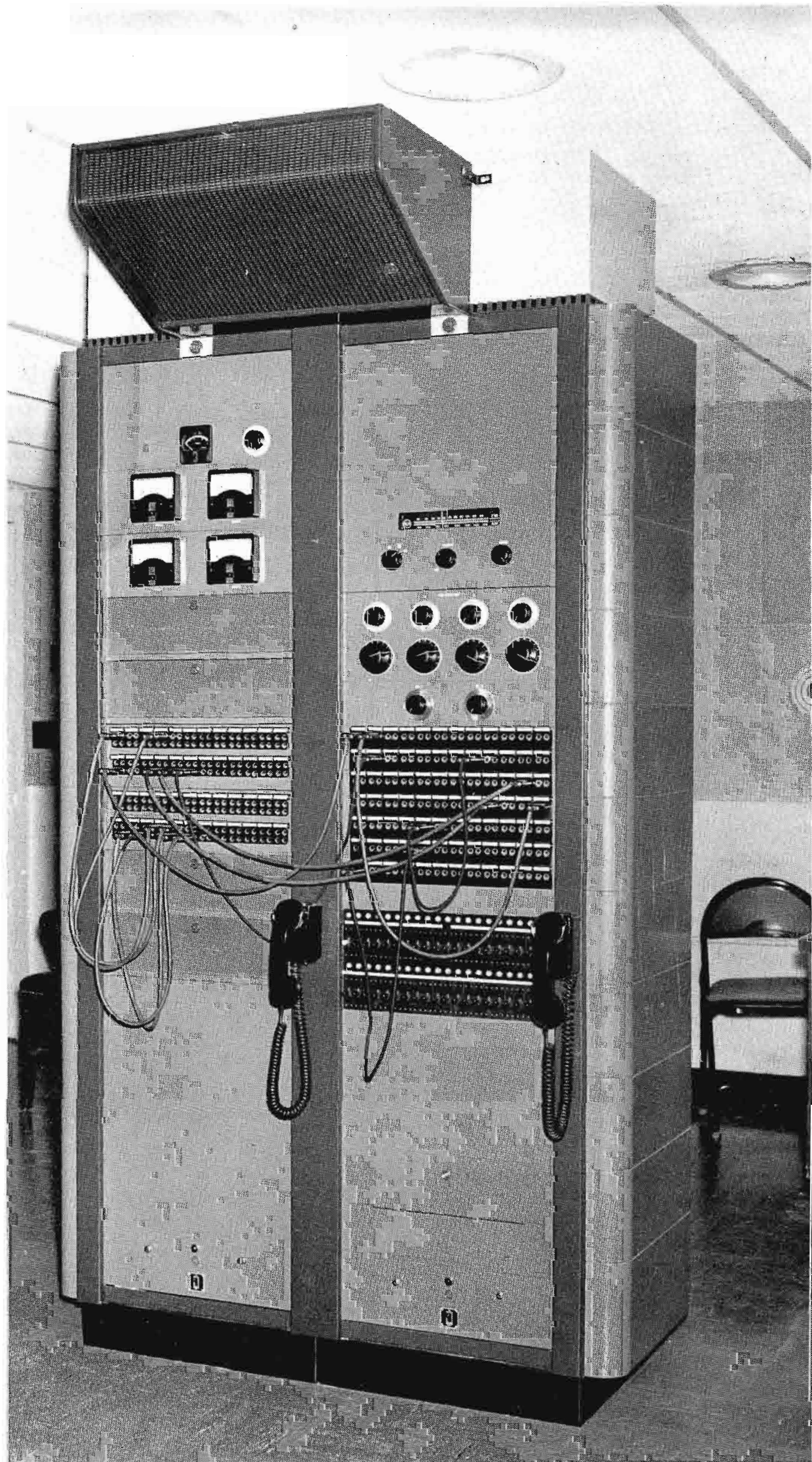

FIG. 10. These two rack cabinets house line terminating and switching equipment, amplifiers, an AM-FM monitor receiver and equalizers as well as other equipment. The four VU-meters are normally connected to each of the four outgoing lines.

RADIO STATION ON WHEELS

**Mobile Unit Remotes Provide Technical
Quality Equal to Studio Program Origination**

by H. W. WELLS,

Station Manager, WFMW, Madisonville, Ky.



FIG. 1. Mobile unit remotes are relayed to station via 450-mc broadcast relay band.



FIG. 2. WFMW in Madisonville, Kentucky began operations as an "FM only" station early in 1949—building contains studios, offices and AM/FM transmitters.

Radio Station WFMW in Madisonville, Kentucky has recently inaugurated a brand new mobile unit in order to give its audience more complete coverage of local events. Excellent results have been obtained by using the new 450-mc broadcast relay band to feed remotes to the station. The RCA equipped mobile unit includes a turntable, tape recorder, BN-2A 4-input remote amplifier and a modified 450-mc RCA "Carfone" two-way radio system as well as facilities for hooking up to three separate power sources.

Vehicle Adaptations

A new GMC "Suburban" vehicle serves as the mobile unit. The two rear seats have been removed and equipment has been mounted on cabinets which have been built into the rear and along one side of the vehicle. The lower portion of these L-shaped cabinets is used for storage purposes. One of the rear seats has been mounted along the opposite side of the vehicle, so that the operator faces the equipment.

Remote Amplifier Facilities

Four inputs are available on the BN-2A remote amplifier in the mobile truck. An inside microphone is permanently plugged into one of these inputs, while an outside mike, an outside remote amplifier and a single 3-speed turntable feed the remaining inputs. The BN-2A amplifier then feeds both the recorder and the transmit-

ter through a Y-pad, so that no switching is necessary. A program can thus be recorded and transmitted at the same time.

Broadcast Relay Equipment

Program material is fed directly from the mobile unit to the studios using an RCA 15-watt "Carfone" transmitter. This transmitter has been modified by RCA, enabling it to be used in a more-or-less continuous duty cycle type of operation. No "cool-off" period (intermittent duty cycle) is needed as in many mobile transmitters, since a thermostatically controlled blower fan is mounted in the top of the transmitter. This equipment which has been assigned the call of KC-8429, operates at 450.05 megacycles.

At the studios a crystal tuned "Carfone" receiver is mounted next to the control board. The frequency response of the "Carfone" equipment is of such quality that it is difficult to tell the difference between a transcription being played at the studio and at the mobile unit!

Public Address System

A public address (PA) amplifier and an FM receiver are mounted directly beneath the mobile unit transmitter and recorder. The PA amplifier feeds the permanently mounted speaker on the roof of the unit. This speaker can be rotated and locked into any position.

Through a switching arrangement, a program can be fed directly from the sep-

FIG. 3. Interior view of the mobile unit shows from right to left, a BN-2A 4-input remote amplifier, tape recorder and modified RCA 450-mc "Carfone" two-way radio system.

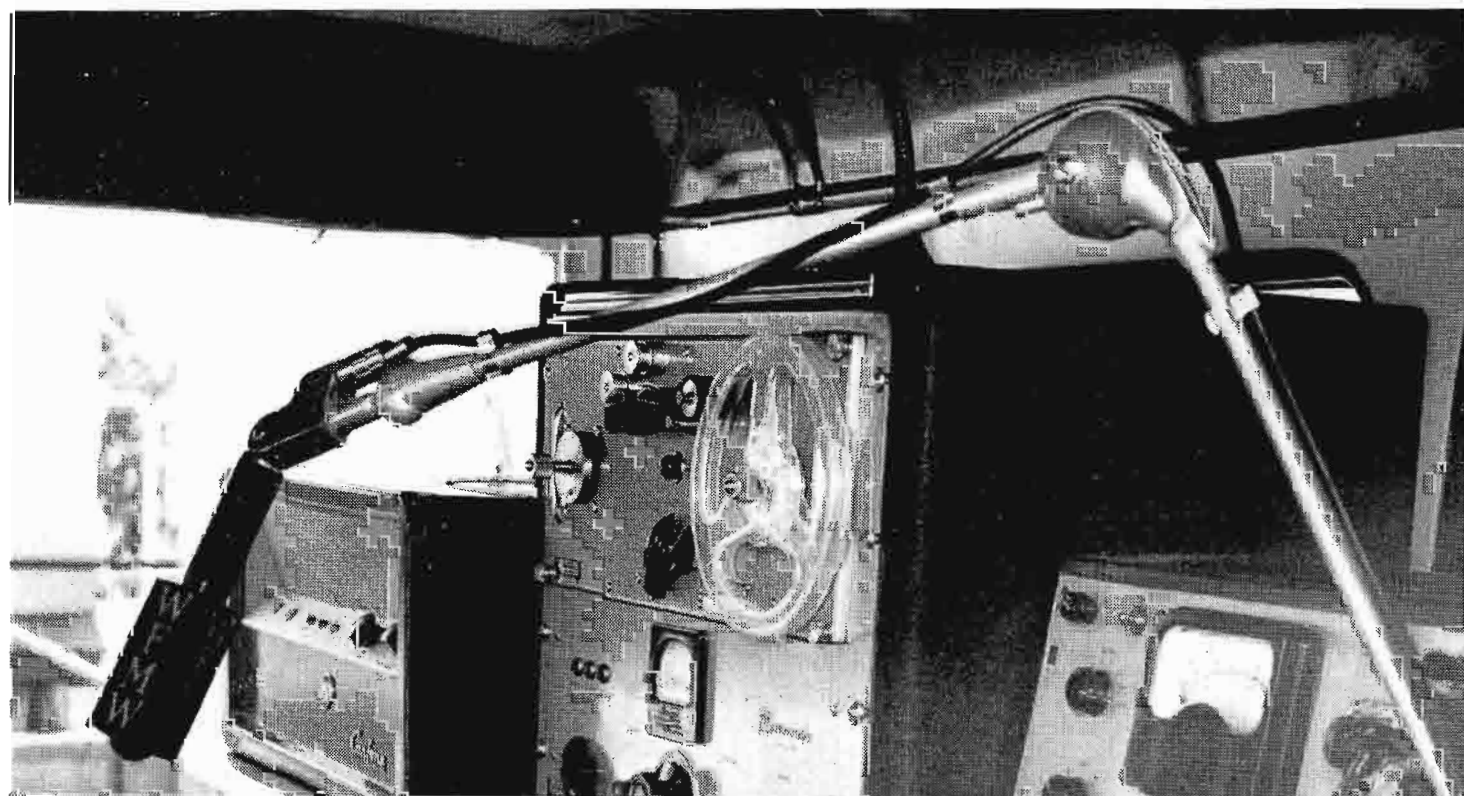

arate PA feed of the BN-2A remote amplifier to the public address amplifier, or the FM receiver will feed into the PA system to put the station's program through the outside speaker.

Transmitting Antenna

Although the Yagi transmitting antenna used in the mobile unit is directional, the unit has been successfully operated within a five mile range of the studios with the antenna in its lowered position. The signal is of such strength that no fading whatsoever has been noticed even when the mobile unit was changing its direction of motion with respect to the receiver location.

Beyond the five mile range, a map and compass are used to orient the mobile unit transmitting antenna so that it is beamed directly towards the receiving antenna.

The Yagi antenna is mounted atop a 20-ft push-up TV mast at the right rear of the truck. The lower portion of this mast is based inside and at the lower portion of the rear fender. A supporting brace has been welded to the mast and bolted to the side of the truck. The three sections are easily pushed up by hand—putting the antenna about 18 ft above ground level. The transmission line is of sufficient length to allow for maximum antenna height. When the antenna is lowered for traveling, the transmission line is merely pulled inside and wrapped around retaining brackets. At the station a 50-ft push-up TV mast supports the receiving antenna.

Power Sources

A total of three separate power sources can be utilized to supply the equipment in the mobile unit. Two of the power sources are built directly into the truck. One is a 12-volt rotary power converter with a manual control to assure constant 50-cycle



FIG. 4. This 500-watt gasoline generator mounted at the right rear of the mobile truck supplies enough power to operate all of the unit's equipment.

110-volt power for tape recording. This unit generates sufficient power to operate the turntable, the BN-2A amplifier and the tape recorder. The other mobile power source, mounted at the rear of the truck (see Fig. 4) is a 500-watt gasoline generator, which supplies sufficient power to operate all of the equipment in the unit at one time, including the RCA "Carfone" transmitter. The third power source consists of a floor-mounted reel containing 200 ft of cable for plugging into a regular 110-volt supply. A switching arrangement beneath the control table is arranged so that any of the three different power

sources may be used. At the same time, the power from any one source is prevented from going back into any other.

Although the motor generator creates considerable noise within the truck, this is barely audible on the air even though the announcer is using the mike inside the unit and within three ft of the generator.

The mobile unit, although just recently licensed, has been used very successfully on several regular programs. Extensive coverage of local events is planned as we become more familiar with the mobile unit's capabilities.

FIG. 5. Main control room showing the "Carfone" receiver just to the left of the studio console. Main studio can be seen through the window in front of the operator.



FIG. 6. WFMW Transmission Room contains, from left to right, an RCA 1-kw FM Transmitter, a panel rack and an RCA 250-watt AM Transmitter.

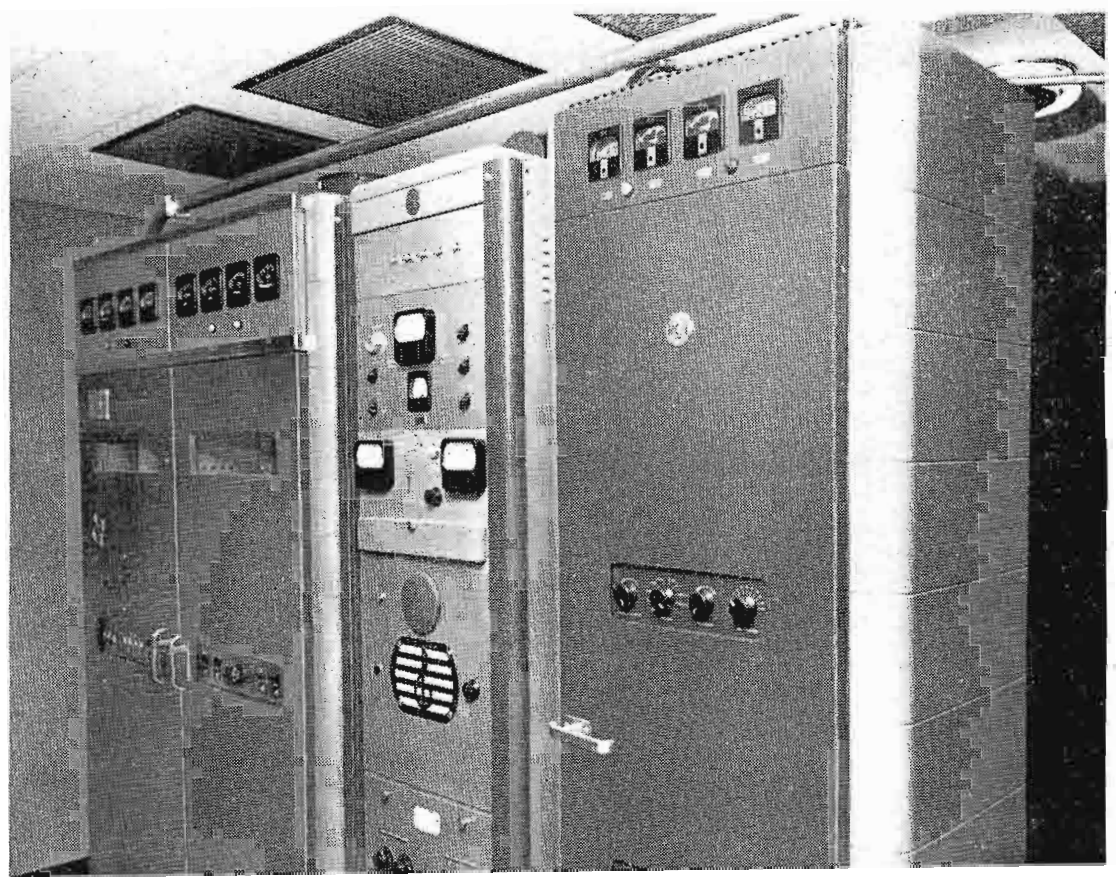

NEW RCA CONELRAD RADIO RECEIVER AUTOMATICALLY WARNS OF AIR ALERTS

For silent monitoring and audible warning of Civil Defense alerts, RCA has recently announced the availability of a new radio receiver, Type CR-17A. The Conelrad receiver operates unattended, provides both visual and audible warnings of air alerts and automatically seeks and finds a Conelrad frequency for radio coverage during a Conelrad radio alert.

Under regulations of the Federal Communications Commission, to become effective January 1, 1957, all stations in the Amateur, Public Safety, Standard Broadcasting, Special Industrial and Land Transportation Radio Services will be required to observe Conelrad alerts for immediate initiation of prescribed Civil Defense procedures.

The Conelrad radio receiver provides a standard radio band for tuning in any local radio station and the two Conelrad frequencies. The user can pre-set, with a simple knob adjustment, the Conelrad frequency assigned to his locality to provide automatic switch-over from standard-band operation to the Civil Defense frequency during emergencies.

The Conelrad receiver is activated simply by turning it on and tuning it to any standard-band broadcast station in the area. The receiver can be operated with the speaker "off" (controlled by a toggle switch on the instrument panel) to provide silent sentry duty. If operated "off", the speaker automatically is switched "on" with the transmission of a Conelrad alert by the station. A green light glows on the instrument panel to advise that incoming broadcast signals are being received, even with the speaker turned "off".

As soon as a broadcast station initiates shut-down procedures, the receiver immediately and automatically shifts to emergency operation. If the speaker is "off", it is automatically switched "on" to receive the complete Conelrad alert from the station. Simultaneously, the receiver begins to shift from the station to the pre-set Conelrad frequency. Should it reach that frequency before the Conelrad station is on

air, the receiver reverts to the broadcast station and continues to shift between the two until it picks up a signal. At the conclusion of the emergency, the receiver automatically shifts from the Conelrad frequency to the broadcast station.

The instrument also provides visual warnings, a series of lights on the control panel, which light up in accordance with changes in receiver operation. When standard broadcast signals are being received the panel's green light stays on. A red light joins the green one to advise visually whenever the station initiates shut-down procedure by cutting its carrier wave. When the receiver completes its shifting cycle, it turns off the red and green lights and flashes on an orange one to indicate it has tuned in the Conelrad frequency.

The receiver also features an external plug-in alarm circuit, providing a 117-volt a-c power source, which can be used to trigger additional warning devices, such as buzzers, bells or lights. The circuit is activated only under emergency operation. The external alarm can be set so that it is triggered by either the broadcast station Conelrad procedure or the presence of the selected Conelrad carrier. Fail-safe features are also incorporated.

The RCA CR-17A Conelrad receiver measures 9½ inches high, 13½ inches wide and 6 inches deep and weighs 15 pounds. The radio receiver, operating on 110-volt a-c power, is also expected to develop wide usage as an alert-warning device in industry, business, institutions and in the home.



C. M. Lewis, Manager, Communications Products Department, Radio Corporation of America, flicks switch putting the new RCA Conelrad receiver on silent guard for Civil Defense air alert.

MAKING THE MICROPHONE A MORE VERSATILE ACOUSTIC TOOL

ART OF DESIGN BECOMING A MORE EXACT SCIENCE AS NEW
METHODS AND A BALANCE OF DESIGN FACTORS ARE REALIZED

by R. M. CARRELL and A. H. LIND
RCA Broadcast Studio Engineering Section

Although microphones are often essentially simple devices, their design has actually been as much of an art as a science. A microphone is expected to have uniform performance over a spectrum that may exceed eight octaves of frequency. The wavelengths range from 21 ft at 50 cps to less than one inch at 15,000 cps. In electromagnetism this corresponds to approximately the range from 50 to 15,000 mc. Imagine the task of broadbanding an antenna to transmit or receive such a range of frequencies with uniform response!

Microphones are in effect personal tools of the artists that use them. This is particularly true in radio, where the microphone is the pre-eminent center of attraction. In television, although the camera commands the primary attention of the artist, he is still surprisingly aware of the ever-present microphone. Since they are objects of attention the appearance of a microphone plays an important part in its acceptance. While appearance is certainly coupled to performance, the problem of achieving the desired end result goes far beyond providing an attractive case.

At the low end of the audio band a microphone is much smaller than a wavelength. Thus one can think in terms of lumped parameters. At the upper end of this range one must contend with distributed parameters, radiation and diffraction effects. This effectively discourages mathematical analysis.

Electrical Analogue Proves Useful

The best practical thing that can be done in this direction is to develop an electrical network analogue of the microphone—then study and analyze its performance as a function of frequency. This

technique is a useful tool which would be used more widely if the analogue were not so difficult to establish.

While very helpful in analysis and reasoning the conclusions must be translated back into acoustical units, i.e., the acoustic designer must fashion the acoustic equivalent of inductance, capacitance and resistance. For inductance he has the mass of air pumped through tubes and slots. For capacitance he has the compliance of diaphragms and of air trapped in cavities. For resistance he has the viscosity of air moving through felt and cloth. Thus the simple mechanical structure of a microphone may actually contain a complex acoustical structure. Usually, every part of a microphone, no matter how innocent it may seem, plays a part in its performance.

Ideally one might expect that a microphone as a transducer should be "transparent," i.e., deliver at its output terminals an electrical representation of the acoustic energy that reaches it without disclosing its presence by introducing distortion, frequency discrimination or spurious signals. Actually, in practice, the presence of controlled characteristics such as directional selectivity may enhance the final result in terms of subjective listening.

Performance with respect to frequency response, distortion, sensitivity and signal-to-noise ratio are of prime importance to the broadcast user. These performance characteristics all tend to be interrelated and collectively determine the fidelity with which a microphone in a given set of surroundings performs its function. The frequency response determines the range of the frequency spectrum to which the microphone is sensitive and also the relative response to sound frequencies within this

range. The smoothness of the response curve and the general relationship of high-frequency to low-frequency response which characterizes the "balance" of the microphone are important criteria.

On-Axis Conditions

When speaking to another person there is a natural tendency to "talk toward" the listener and likewise when listening there is a natural tendency to face toward the source of sound. Thus in general an "on-axis" condition exists for the most natural or balanced sound to the listener. The simplest technique for "on-axis" pickup would be to place an ideal microphone directly in front of the speaker's mouth. This, of course, would place very stringent limitations on the position and movement of an artist. The degree to which "off-axis" relationships between artist and microphone can be accommodated while maintaining satisfactory response depends greatly on the microphone design.

In radio broadcasting the artists can generally be grouped so as to be contained within a reasonable and more or less fixed solid angle centered on the microphone axis. In TV broadcasting this is not nearly so much the case since, in a large portion of TV scenes involving people, one goes to great lengths to remove any microphone from sight. This is usually accomplished by concealing microphones on the performers, or in props on the set, or by positioning a microphone as closely as possible while keeping it just outside the field of view. In any case the microphone position might be such as to be receiving sound appreciably "off-axis".

Perhaps an extreme case is that of the artist wearing a concealed microphone on



FIG. 1. Anechoic, or echoless room used for testing microphones at RCA. Wedges of Fiberglas 3 to 6 ft deep line the room.

his chest. The microphone axis and the artist's mouth axis could easily be at right angles to each other. Real voice-spectrum measurements have been made under such conditions to determine how the voice energy that reaches such fixed positions compares with that found directly in front of the mouth. The design of a personal microphone intended to be worn by the artist must reconcile such variations to result in a natural balance of the sound pickup.

Distortion

The degree to which a given sound pres-

sure wave is not duplicated as an electrical wave constitutes distortion in a broad sense. Thus amplitude and frequency characteristics all contribute to distortion when complex waves are involved. Amplitude distortion generally appears as the moving elements approach the limit of their control range. Sound waves of greater intensity will cause overload which might permanently damage such elements. The dynamic range over which a microphone is useful is contained between the acceptable limit of distortion at the high sound-intensity end and the residual noise level at the low-intensity end. For a broadcast quality

velocity microphone the dynamic range is about 100 db in sound intensity. This represents the range between a weighted self-generated noise equivalent of plus 20 db relative to the threshold of hearing at 1,000 cps and 1 per cent amplitude distortion of a 100 cycle sound wave at plus 120 db relative to the threshold of hearing at 1,000 cps. At higher frequencies the 1 per cent amplitude-distortion limit occurs at still higher sound pressures, well in excess of the threshold of pain.

If the overall frequency response is not proper, the balance is affected as was dis-

discussed previously. This constitutes signal distortion in the rigorous sense. The signal-to-noise ratio performance of a microphone in a given surrounding is effectively the ratio of wanted to unwanted output. The unwanted output is contributed by both electrical and acoustical causes.

Noise

Since noise in the amplifier and microphone will determine the faintest sound that can be picked up, let us assume a microphone sensitivity and then refer our noise levels to equivalent sound pressures. Taking a microphone sensitivity of -53 dbm such as the RCA 77-DX for a sound pressure of 10 dynes/cm, (94 db sound level) we should find that an amplifier noise level of -123 dbm would be equivalent to an acoustic signal of 24 db above the threshold of hearing at 1,000 cps. This is some 50 or 60 db below normal conversational level.

A microphone will have self-generated noise due to thermal agitation. If a suitable weighting function is applied to the noise output from a good ribbon microphone, we obtain a noise level equivalent to a sound pressure of about 20 db above the threshold of hearing at 1,000 cps. Dynamic and capacitor microphones have slightly greater inherent noise levels.

Magnetic induction pickup in the microphone is usually evidenced as hum pickup

since fields resulting from a-c power circuits are generally the most prevalent. Thus, signals of 60 cps and its harmonics are most commonly encountered. For a field of 1 milligauss which is used for rating purposes, the hum output level of an excellent ribbon microphone is -128 dbm. This would correspond to a weighted 10,000 cps sound pressure of plus 11 db relative to the threshold of hearing. The hum level in broadcast studios and control rooms may average 12 to 15 db above the 1 milligauss rating reference level. The hum pickup is thus about the same as the weighted equivalent output due to thermal agitation effects.

The limiting noise in a broadcast audio system lies, therefore, in the inherent noise, first of the microphone, then of the amplifier. This inherent noise is due to the random motion of the electrons in the tubes, the wires and in the microphone itself. No amount of amplification will improve the signal-to-noise ratio once the thermal agitation noise level in the microphone and amplifiers is reached.

It is important to note that the inherent noise levels of the microphone and amplifiers correspond to sound levels only 20 db or so above 0.0002 dynes/cm, the threshold of hearing. This is a very low acoustical noise level, which has been only rarely attained even in specially constructed anechoic or "dead" rooms.

Noise may also be generated by air moving past the microphone. This "wind noise" may arise, even in a studio, from drafts from ventilating systems, from rapid movement of the microphone on a boom or by breathing on the microphone. Quantitative measurements of wind noise have been made on ribbon microphones by using a swinging pendulum technique.

In one case it was found that, when the wind velocity exceeded $2\frac{1}{4}$ miles per hour (3.3 ft/sec), the weighted wind-noise signal exceeded the output due to thermal agitation. The wind-noise spectra of the 77-D microphone for a 10 mile per hour wind are shown in Fig. 2.

In addition to the foregoing, still another source of noise signal is the extraneous airborne sounds that reach the microphone. Sound levels below plus 30 db are rarely encountered. The sound level in TV studios is as a rule appreciably higher. Thus, the noise level that determines the lower limit of useable dynamic range is almost always established by noise signals other than in the microphone or preamplifier input.

Directional Selectivity

The directional sensitivity of the microphone can be a major asset in controlling and suppressing unwanted direction and reflected pickup. The use of unidirectional boom microphones is currently universal in TV. There appears to be a similar trend in radio as well. In recent designs such as the BK-5A careful attention has been paid to the directional characteristics. Figure 3 shows the directional characteristics in all three planes. Current development work is pointing the way toward more sharply directional microphones.

A Miniature Dynamic Microphone

A growing need for a small, inconspicuous, "personal" microphone that could easily be attached to a person's clothing led to the development of the RCA BK-6A which was introduced to the broadcast industry in mid-1955. It was the smallest self-contained broadcast quality microphone available to the industry. Its development used "real voice" techniques and equipment made at RCA during the initial development of high intelligibility military combat communications systems.

The BK-6A was immediately successful and has become widely used in both television and radio. Broadcasters soon experimented with it for other sound pickup applications. For some concealed microphone applications where the BK-6A was not worn by an artist, increased bass response seemed necessary.

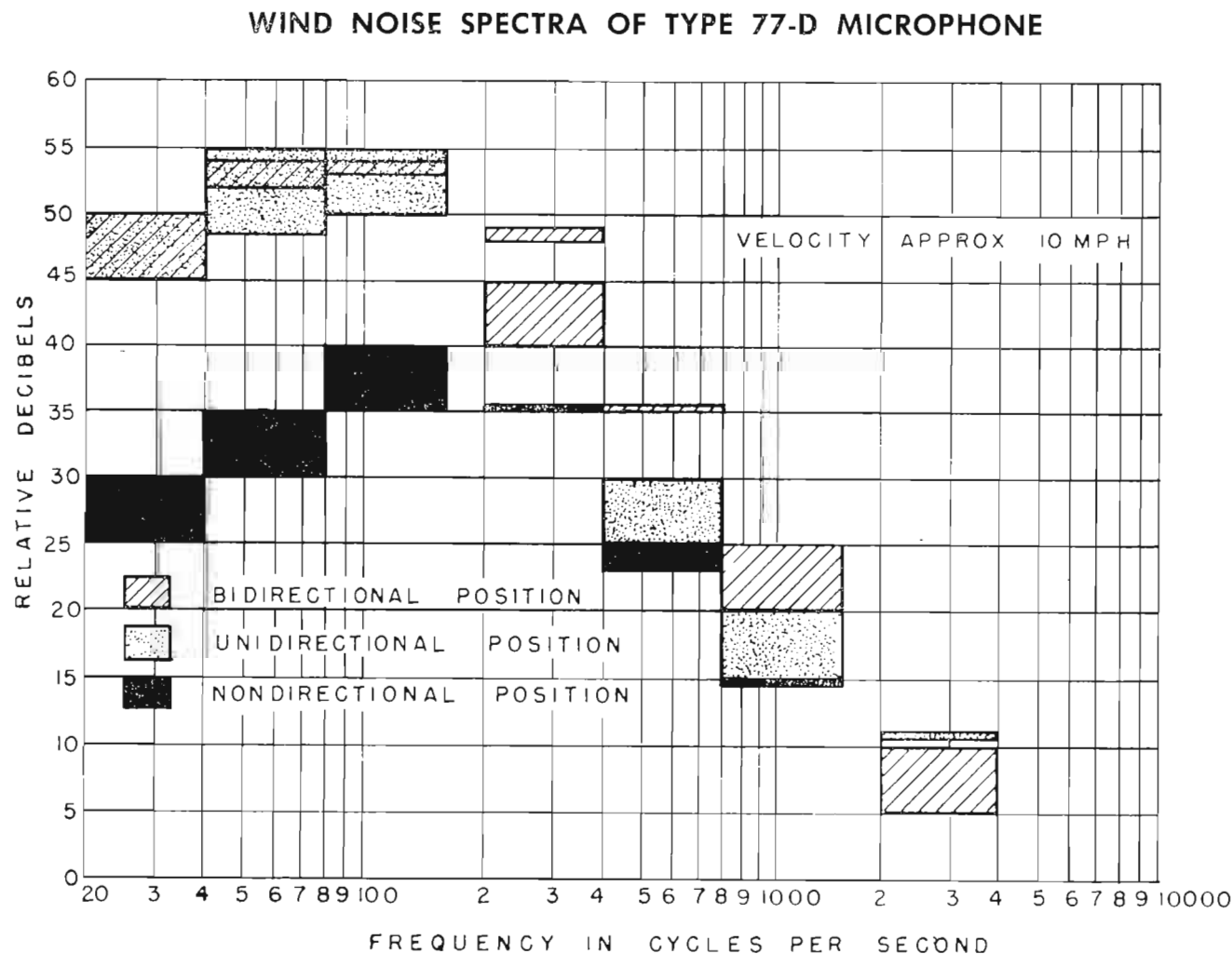

FIG. 2. Wind noise spectra of the 77-D microphone obtained by plotting relative db versus frequency in cycles per second.

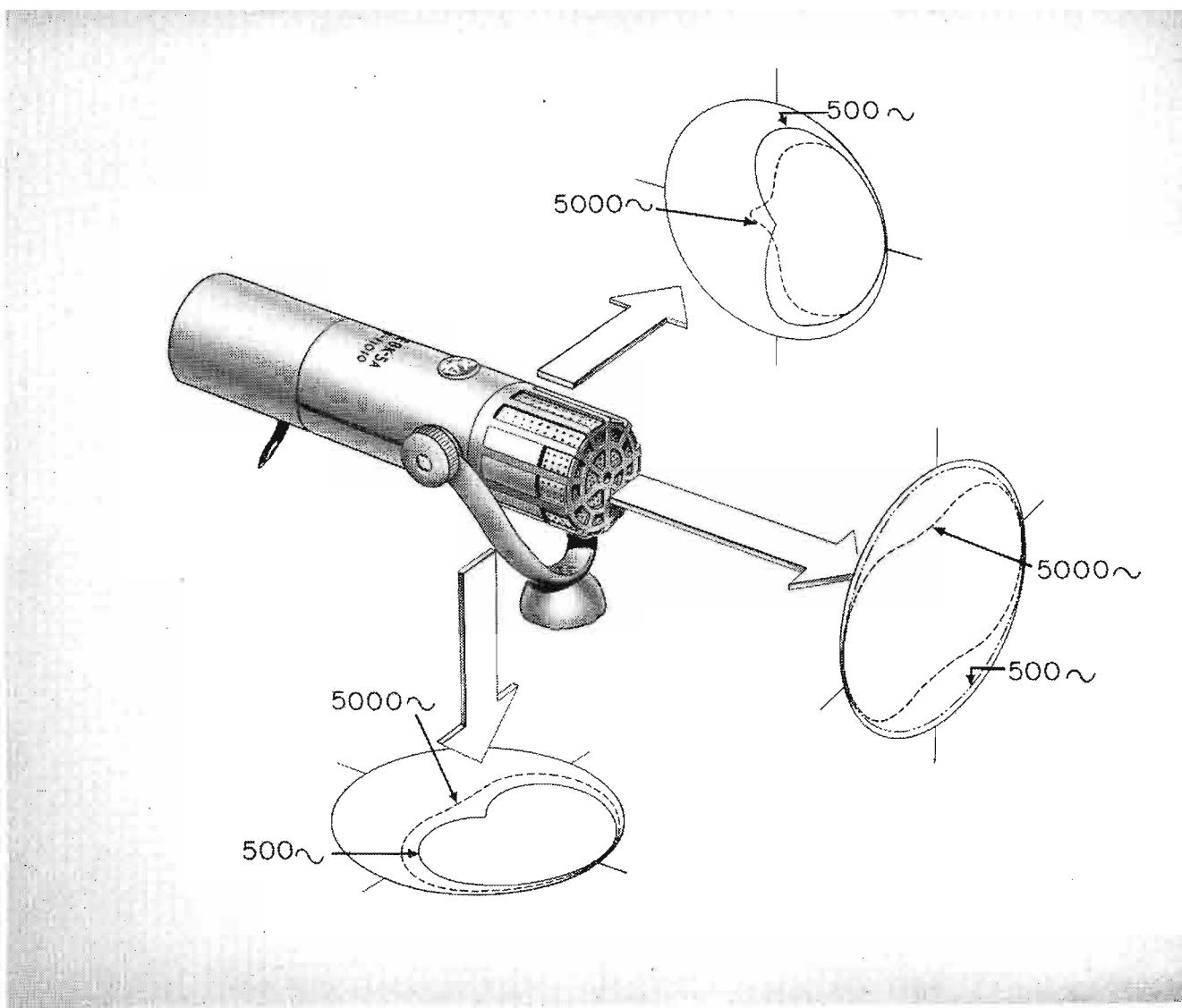

FIG. 3. Directional characteristics of the BK-5A microphone shown in three planes.

In addition there were requests for a still smaller microphone that could be even more readily concealed. The two requirements of smaller size and increased low-frequency response appeared contradictory from past microphone design experience. However, follow-up engineering development was continuing on the BK-6A in an effort to reduce its size. This program then also acquired the goal of improved low-frequency response—both of which were achieved. The

response of the BK-6B compared to the BK-6A is shown in Fig. 4.

While the increased low-frequency response and the lesser accentuation of the high-frequency response is apparent, this is not excessive for use on the chest. Even in this position, listening tests have resulted in a consensus that the balance has improved. For general-purpose applications the performance has been improved. Figure 5 illustrates the reduction in size.

Field Application

One of the first applications of the BK-6B was its use in a Denver judicial proceeding, early in February 1956, where the American Bar Association Canon 35 (which effectively excludes radio and television pickup from court proceedings) was successfully contested. Figure 6 shows the judges' bench in a general court scene and how the BK-6B's were inconspicuously tucked away in the recessed corners

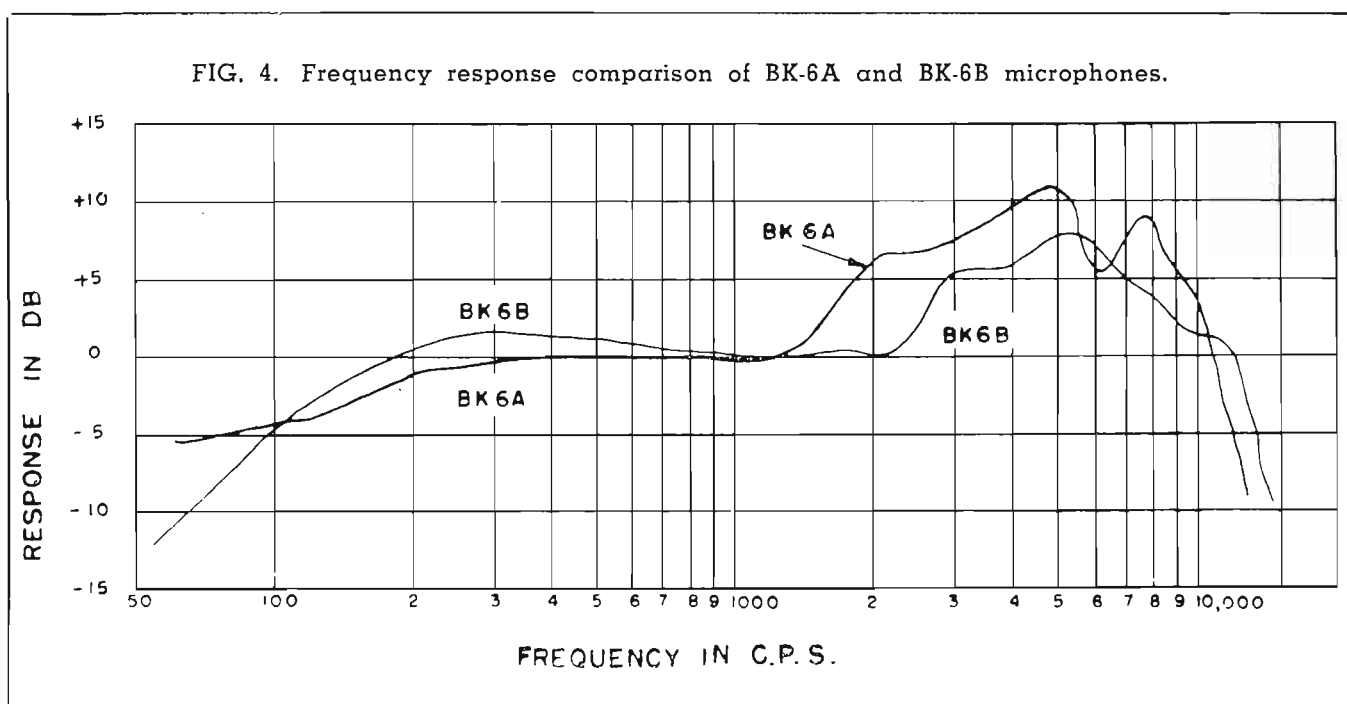

FIG. 4. Frequency response comparison of BK-6A and BK-6B microphones.



FIG. 5. A considerable reduction in size has been achieved in the BK-6B microphone (right) when compared to the BK-6A.



FIG. 6. Judges' bench at the Denver Court Hearing—note the inconspicuous BK-6B microphones shown circled in the photograph and in detail in the inset.

of the judges' bench. Thus the BK-6B played an important role in the broadcaster's crusade to becoming an even more complete public servant in the dissemination of news and information. We are indebted to Mr. Joe Herold of KBTv, Denver for these courtroom photographs.

Listening Tests

The proper evaluation of a studio microphone must include subjective as well as objective factors. Thus listening tests play an important part in the evolution of a microphone. Objective tests are best used as a guide and as an aid to quality control.

Operational tests which include listening tests in sound rooms under closely controlled conditions as well as in studios under normal operating conditions can be very helpful in evaluation. Such tests are subjective, with the human ear being a very important part of an overall test, and are thus most safely employed when making

comparative tests rather than absolute tests. They are most satisfying when making acceptance tests of an essentially completed design. Measurements are made to obtain more scientific objective data which can be tabulated, or plotted, with mathematical simplicity and precision.

Testing a microphone requires special and often costly facilities. Primary among these is the anechoic, or echo-less room. This is best accomplished by lining a large room with wedges of Fiberglas three to six feet deep. The room itself must also be quiet. This usually means that it is built in a separate building, or that the entire room must be suspended from the frame of the building.

Test Procedures

Frequency response calibration is obtained in such a room by placing the microphone a few feet in front of a wide range loudspeaker in the room. First the sound field is calibrated at the test point with a

standard microphone of known response. Then the test microphone is substituted and the response curve obtained is compared with that of the standard.

Directional characteristics are obtained by rotating the microphone before the speaker. This procedure works well for microphones which are used in front of the artist, like the 44-BX, 77-DX, BK-5A and the BK-1A. If the microphone is to be worn by the performer, such as the BK-6A and the BK-6B, then the measurements made in front of a loudspeaker may be misleading. This is because the balance of high and low frequencies on a person's chest is not the same as in front of the face. The microphone must be constructed so as to compensate for this difference. To determine what the proper response for a chest microphone would be, the technique of real voice measurement could be called into use.

This involves using an integrating audio spectrum analyzer to measure the spectrum of a talker's voice a foot or two in front of his face, and then compare this spectrum with that found on his chest. The difference between these spectra would then indicate the proper frequency response characteristic for the chest microphone. Figure 7 shows the integrating audio-spectrometer which is used for this work and Fig. 8 shows a block diagram of the audio spectrometer.

The technique used in this analysis is to record on tape a phonetically balanced sentence such as "Joe took father's shoe-bench out, she was waiting at my lawn", by means of the microphone being tested. This tape can then be reproduced repeatedly and the relative energy content within limited frequency bands measured by using narrow, sharply-defined band pass filters and an energy integrator. Measurements are made for a sufficient number of bands to cover the spectrum of interest. For convenience, octave bands are quite generally used in these measurements.

There are other characteristics which are as important to the utility of a broadcast microphone as frequency response. These

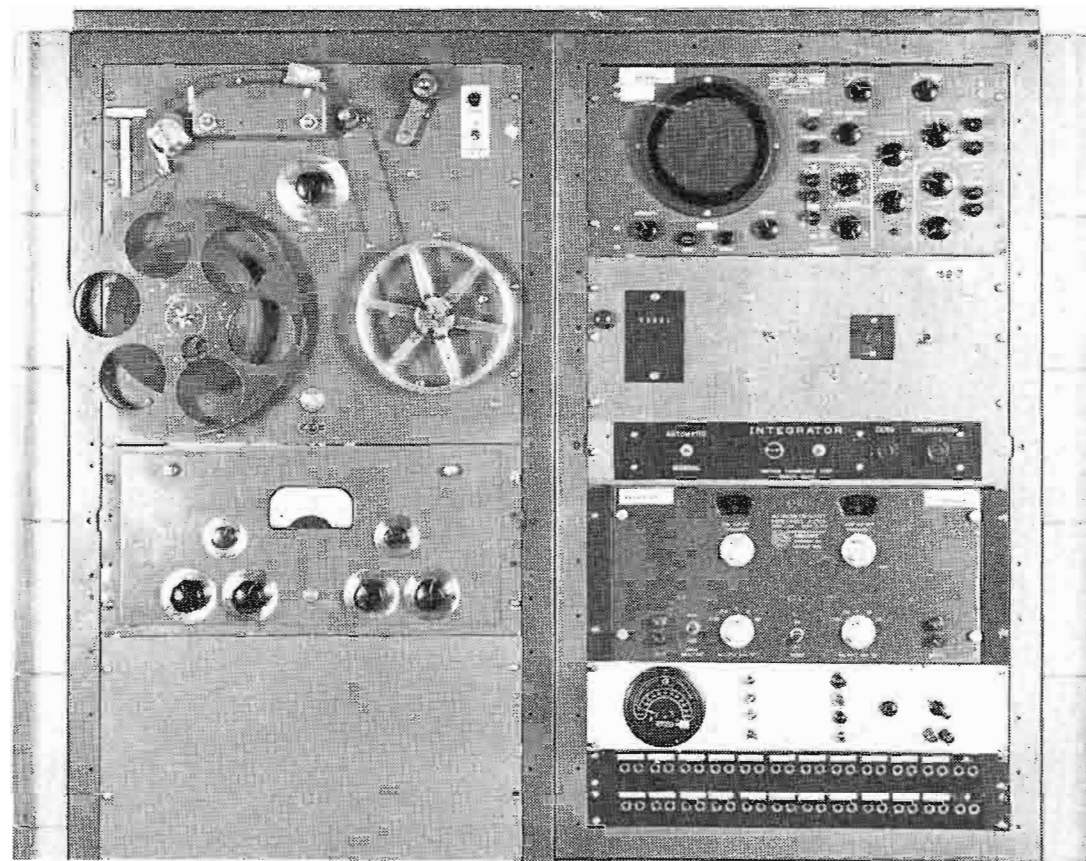

FIG. 7. Integrating audio spectrum analyzer used to determine proper response for chest microphones when employing real voice measurement techniques.

too, must be controlled and to be controlled a test means must be available.

Hum pickup is an important characteristic. A large coil 6 ft in diameter, is used to generate a uniform hum field in which microphones can be compared and given absolute ratings. Hum pickup as part of its standard specifications was first introduced by RCA.

Another important characteristic is wind noise for which there are no standard test methods available as yet. At RCA we have been swinging the microphone on a long pendulum and using a filter and a high-speed recorder to measure the wind-noise output at the bottom of the swing.

It appears desirable to develop a standardized method of measuring wind-noise susceptibility to establish ratings that can appear as part of the performance specifications. Work recently reported by the BBC in London indicates an approach very similar to that used at RCA. Such a rating would make available one more item of

data that should prove useful to the broadcaster in selecting microphones for various applications.

The trend of microphone developments is first toward more sharply directive microphones for stand or boom use and, secondly, smaller, but yet high quality personal microphones for concealed usage. Both types must have the continuing requirements of comparable balance and sameness in sound when used in their intended application. Further, the application of real voice spectrum measurement to broadcast microphone design and the steps being taken toward a wind noise rating specification are helping to reduce the art of microphone design to a more exact science.

The factors which are balanced to make a microphone a versatile acoustic tool have been but briefly surveyed. Like any tool, it must be used with a skillful understanding of its capabilities and limitations to obtain best results in the hands of a broadcast engineer.

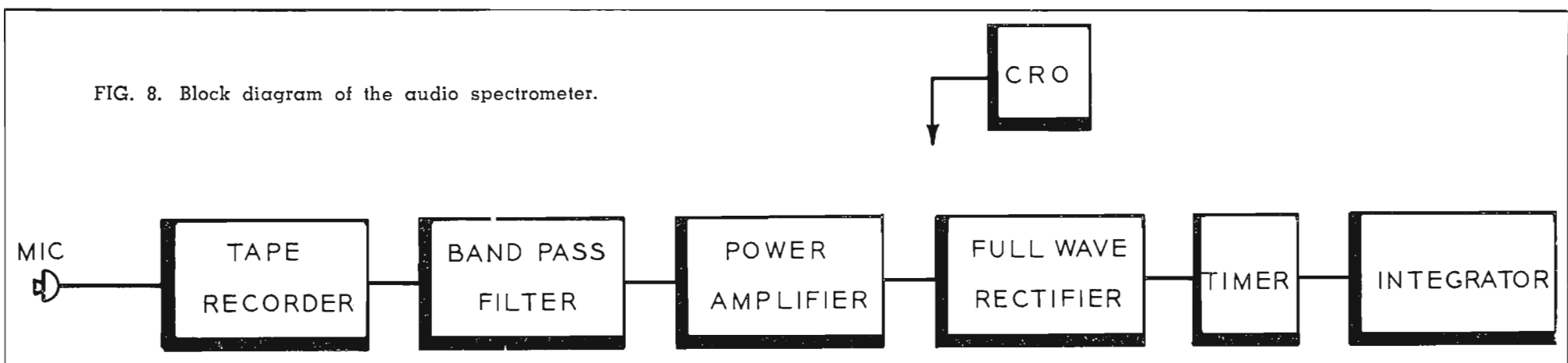

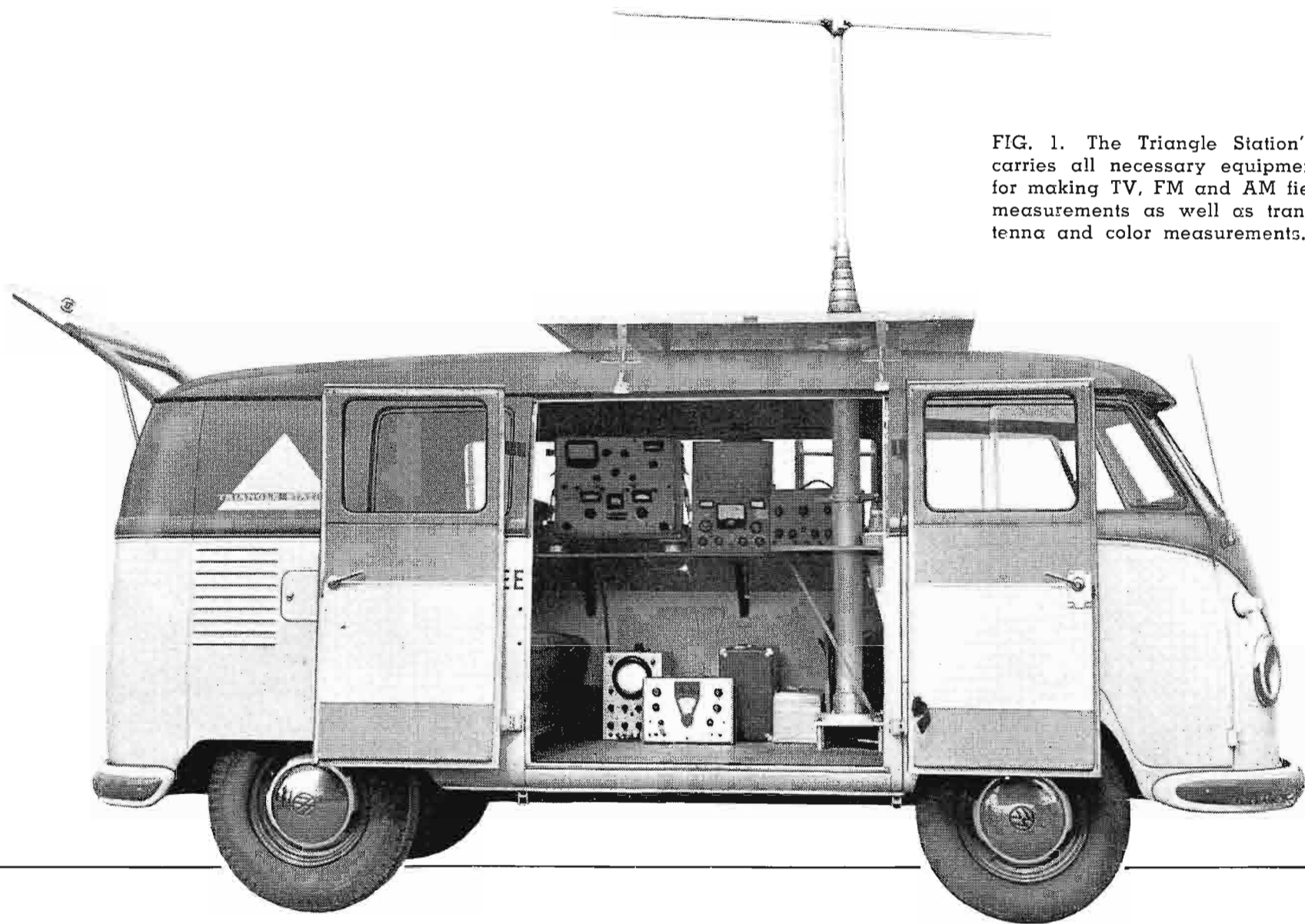

FIG. 1. The Triangle Station's Microbus carries all necessary equipment required for making TV, FM and AM field strength measurements as well as transmitter, antenna and color measurements.

A MOBILE TEST AND MEASURING UNIT FOR AUDIENCE RESEARCH

Station Coverage and Transmitting Equipment Checks of the Various Triangle AM - FM - TV Stations Are Made Using a Mobile Field Engineering Unit. Vehicle Minimizes Equipment Duplication and Standardizes Procedures for Acquiring Various Forms of Data

by HENRY RHEA, *Director of Engineering, Radio and Television Division, Triangle Publications, Inc.*

All segments of the broadcasting industry and the advertising fraternity are vitally interested in audience. Where is a station's audience? How large is it? What kinds of people comprise this group? Audience research has become big business.

Broadcast audience research is traditionally and realistically an engineering function. The actual measurement of the complete coverage pattern of a station is the best yardstick on which to base evaluation of a station's ability to serve advertisers and the public alike.

Recognizing these facts, the Radio and Television Division of Triangle Publications, Inc., has developed a Mobile Field Engineering Unit which researches these

data for all of its stations on a continuous basis. By combining creative broadcast engineering with what might be called a "modern design" vehicle, the Triangle Stations achieved a solution to the vital audience measurement question.

Triangle Publications, Inc. operates the WFIL stations in Philadelphia, Pa., the WNBF stations in Binghamton, N. Y. and WFBG-AM-TV in Altoona, Pa. Applications are pending before the Federal Communications Commission for the transfer of WNHC-AM-FM-TV in New Haven, Conn., and WLBR-TV in Lebanon, Pa.

Handles Wide Range of Measurements

Considerable differences exist in the transmitting equipment being used at the

various Triangle stations. Moreover, the TV stations operate over a wide range of frequencies. WFIL-TV is on Channel 6, low band VHF; WNBF-TV, WFBG-TV and WNHC-TV operate on high band VHF; and, WLBR-TV is assigned UHF Channel 15. In addition, terrain conditions vary greatly among the stations—ranging from the mountainous territory around Altoona to the relatively flat country around Philadelphia.

Great variations exist, therefore, in the technical operating conditions of the stations. Obviously, there are differences in the test and measuring procedures used. This is not a vital factor because each station is equipped with a competent engineering staff. However, it would seem that

some standardization in these procedures would be desirable and might result in some efficiencies. Also, measured contours were not available for some of the stations and such data are becoming increasingly important to the sales and promotion departments.

To accomplish these objectives, the construction of a mobile test and measuring unit that could be used for all Division stations was considered. The availability of such a unit would not only minimize the duplication of certain expensive equipment but would insure uniformity of all data. Thus, such data would become more significant and better permit direct comparisons and more intelligent analysis. After some study and discussion with the various station engineers, this project was undertaken in late 1955.

Selecting the Most Practical Vehicle

The equipment presented no particular problem. Apparatus was obtained from RCA for measuring and recording field strengths for TV, FM, and AM as well as for sweeping transmitter and antenna systems, and for making color measurements.

The vehicle itself was another matter. The equipment occupies a considerable amount of space but a truck size vehicle was out of the question. The unit had to be capable of getting in and out of tight spots and stand up under very rough driving conditions. Its movement could not be restricted to the paved highway, yet it must be large enough to house comfortably the above equipment plus the necessary operating personnel. Several station wagons of American manufacture were investigated and in varying degrees met all the requirements except the one of adequate room. The Volkswagen Microbus designed to carry eight people was next inspected and appeared to meet all the requirements, including the one of room with the possible exception of not having sufficient power to travel over the kind of roads and terrain expected to be encountered. It was decided to utilize the Volkswagen because a supercharger capable of increasing the horse power delivered to the wheels by approximately 50 per cent was available and could be installed if necessary. The bus was purchased and the equipment was installed as shown in the accompanying photographs.

Figure 1 shows the floor space available within the bus resulting from the removal of the middle seat. A double door on the right side provides a wide step-up entrance. A shelf constructed on the left side of the unit supports the RCA BW-7A TV and the WX-2D AM Field Intensity Measuring sets.



FIG. 2. View of hydraulic antenna mast control lever and facility for rotating.

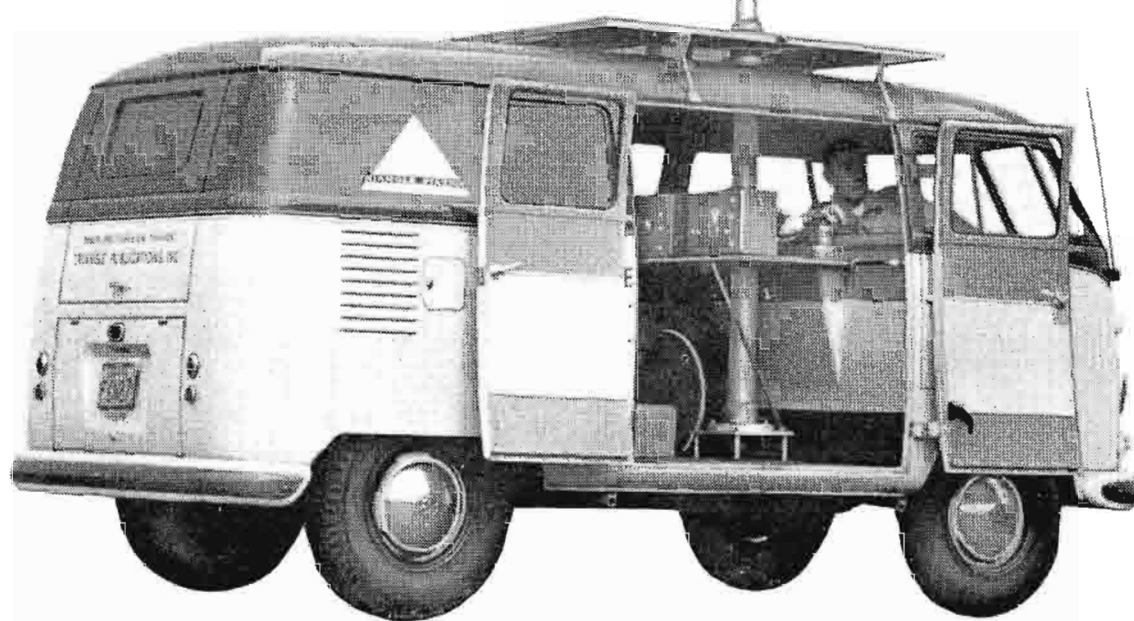

FIG. 3. Telescoping antenna mast, fully extended. Full height is 30 ft., but most measurements are made at 10 ft.

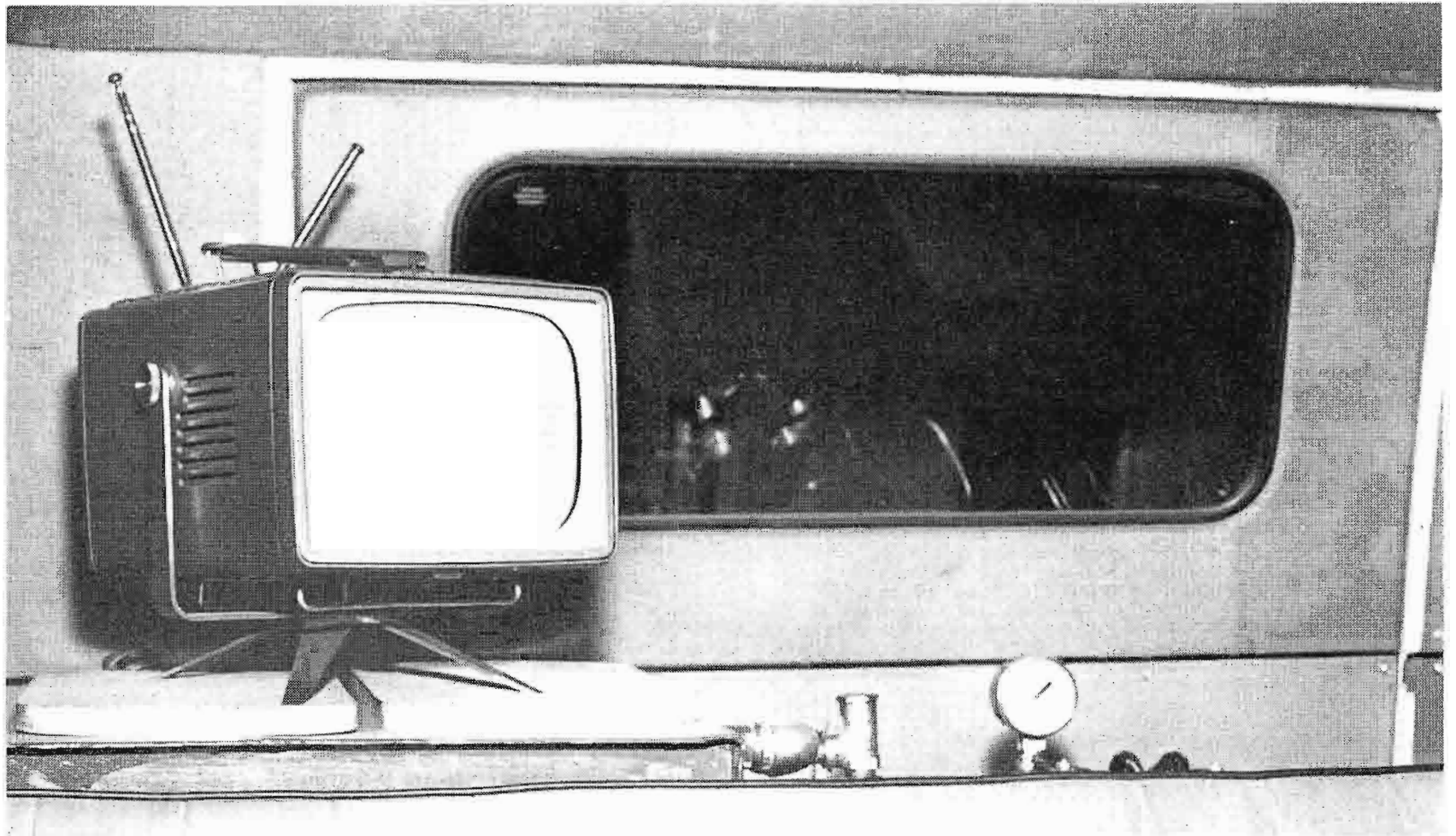

FIG. 4. A portable RCA 7-inch Television Receiver serves as an excellent monitor. The 110 volt a-c power is supplied by a 350-watt Leece-Neville alternator feeding a Leece-Neville transformer shown in photo below.

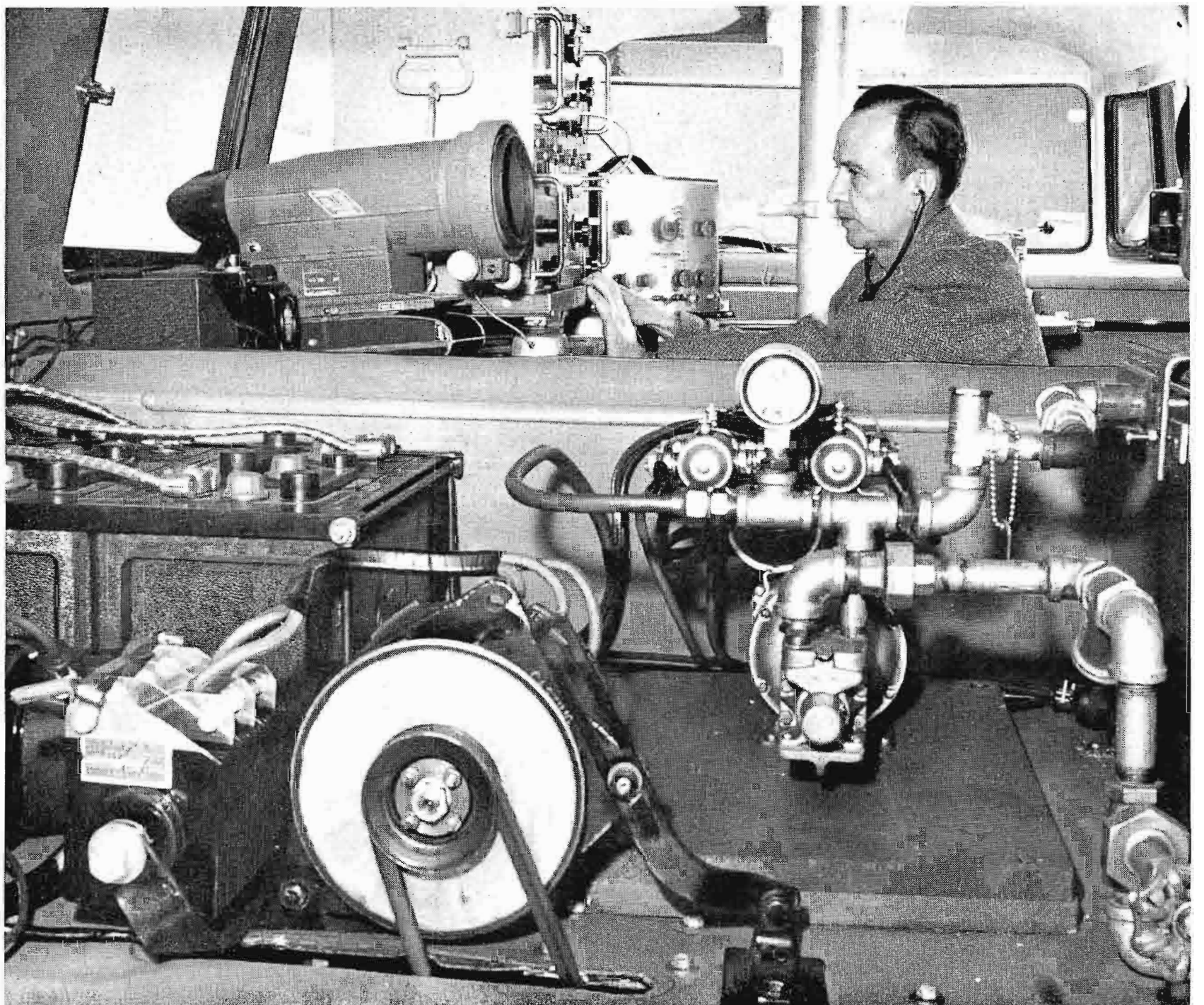

FIG. 5. View showing two 170 ampere hour batteries and alternator (left) and hydraulic pumping system (right).

TV and FM Field Strength Measurements

The RCA BW-7A Field Intensity Meter and Test set operating over a range of 54 to 240 mc. was chosen for measurements in the TV bands and served for FM measurements as well. This unit provides continuous tuning, avoiding the need for band changing. It is a lab-quality signal generator and receiver combined in a single convenient case. Television signals may be measured at either "average" or "peak-of-sync". An output is provided for a standard Esterline-Angus Recorder which we use in conjunction with the BW-7A for visual recording of the signal under test. The recorder is driven by the vehicle's speedometer cable. The BW-7A operates from a 6-volt battery or 115 volt, 50/60 cycle supply.

The BW-7A test set includes an antenna carrying case containing a tripod, mast section and tee, extension mast section, two dipole elements, 35 ft. of antenna cable and a 40-db attenuator. This equipment was modified slightly to provide a variable-height antenna arrangement which could easily be rotated or elevated to any height (see Figs. 2, 3 and 6).

The hydraulic antenna mast and control lever are shown in Figs. 2, and 3. The hydraulic system tank and other accessories to the antenna mast are shown in Fig. 5. The mast can extend the antenna to 30 ft. above ground, but most measurements are made at 10 ft. This equipment was provided and installed by the Thomas Mold and Die Company of Worcester, Ohio.

On the roof of the bus is a rigid metal platform—more than adequate for supporting the weight of an engineer. The platform facilitates a change of antennas—from high band to low band VHF or vice versa. This platform is accessible by climbing a removable light-weight ladder which hooks into the frame of the platform and is supplied by Hagen-Felt Corporation of East Orange, New Jersey. (See Fig. 6.)

Antenna Sweep Measurements

Under the shelf shown in Fig. 1 the antenna sweep measurement apparatus is carried. This equipment is used for determining antenna bandwidth, checking for open or shorted transmission lines and indicating the presence of standing waves. The sweep measuring equipment consists of an RCA WR-89A Crystal Calibrated Marker Generator and the WO-88A 5-inch Oscilloscope. Ample space is available below the shelf for color measuring equipment such as the RCA WA-6A Color



FIG. 6. View of bus showing rigid metal platform for supporting engineer when changing antennas—also removable light-weight ladder.

Signal Analyzer and WA-7B Linearity Checker, used from time to time.

AM Field Intensity Measurements

For AM measurements the RCA Field Intensity Meter, Type WX-2D is used. This unit, shown on the shelf in Fig. 1, is "hand carried" to derive surveys in the broadcast band. The instrument cover contains a loop antenna, loaded with a high "Q" coil to provide the total inductance required for the operating range of 540 to 1600 kc. The WX-2D is small, light in weight and has a wide sensitivity range of 10 microvolts/meter to 10 volts/meter.

Power Supplies, Monitor, 2-Way Radio

In the rear of the bus, as shown in Fig. 5, are two 170 ampere hour storage batteries. Switches located under the work shelf and easily accessible to the engineer permit charging one battery while the other is in use. Both can also be charged at the same time.

A Leece-Neville 350-watt alternator (Fig. 5), belt driven by an extra pulley added to the motor crankshaft, is used for charging. The alternator also feeds a

Leece-Neville transformer which provides 110 volts a-c for operating the portable RCA television set, shock mounted over the hydraulic system tank (Fig. 4). Incidentally, the set is quite useful in areas where high reflected signals exist.

A 125-watt converter was also installed for providing another source of 110 volts a-c. Back of the front seat, a radio telephone provides the necessary communications for co-ordinating with the main transmitter.

The Field Engineering Unit has been in service for several months and to date has proved very satisfactory. A permissible top speed of 50 mph is no particular handicap, the bus has adequate power to pull through muddy fields and up steep hills—gas mileage is better than 25 miles per gallon. The roominess of the interior permits good efficiency and speeds up operations. No service other than lubrication has been required since the bus was put into service. The delicate equipment has been transported several thousands of miles without a single mishap. Total cost was approximately eight thousand dollars and the expenditure has proven well worth while.

HIGHLIGHTS OF HOW NBC COVERED THE 1956 POLITICAL CONVENTIONS

The photographs on these two pages illustrate some of the unusual means used by NBC to cover the recent political conventions. In order to provide the necessary mobility both inside and outside the convention halls, RCA and NBC engineers came up with several innovations. For inside mobility these consisted of ultra-portable vidicon cameras and perambulator-mounted IO cameras. Outside mobility was achieved by using a special "Traveling" mobile unit with microwave relay facilities, and a truck-mounted "Hi-Lift" camera platform. The use of these devices enabled NBC to provide outstanding shots of special events and personages.



FIG. 1. TV camera operated from a Hi-Lift truck-mounted platform, capable of extending to a height of 70 ft was one of the devices used for obtaining difficult pickups. Here it is shown covering Adlai Stevenson's movement from the Stockyard Inn (shown above) to the Amphitheatre. Later on it saved the day on the occasion of the President's arrival at the St. Francis Hotel in San Francisco. With less than two hours to go after being unable to find a satisfactory outside camera location for this event, the Hi-Lift was set up at the hotel, cable connected with the NBC mobile unit and a picture fed to TV control—all in about one hour.



FIG. 2. Main studio control room monitor table, showing the various picture sources handled during a representative part of a convention day.

FIG. 3. Transceiver for audio pickups at left, NBC "PRAM" camera in center, and transistorized ultra-portable one-half inch vidicon TV camera at right. The "PRAM" camera consisted of a standard perambulator mike boom with an image orthicon camera instead of a boom arm mounted on the vertical support. The "PRAM" cameras proved singularly useful for caucus room coverage. Since these rooms were constructed without ceilings the use of a "PRAM" camera (with Zoomar lens) eliminated the necessity of gaining admission to the caucus room—by merely shooting over the walls very effective shots were gotten.



FIG. 4. Commentator Ben Grauer reports from convention floor, using "beer-mug" radio microphone. This is a crystal-controlled UHF AM transmitter and microphone.

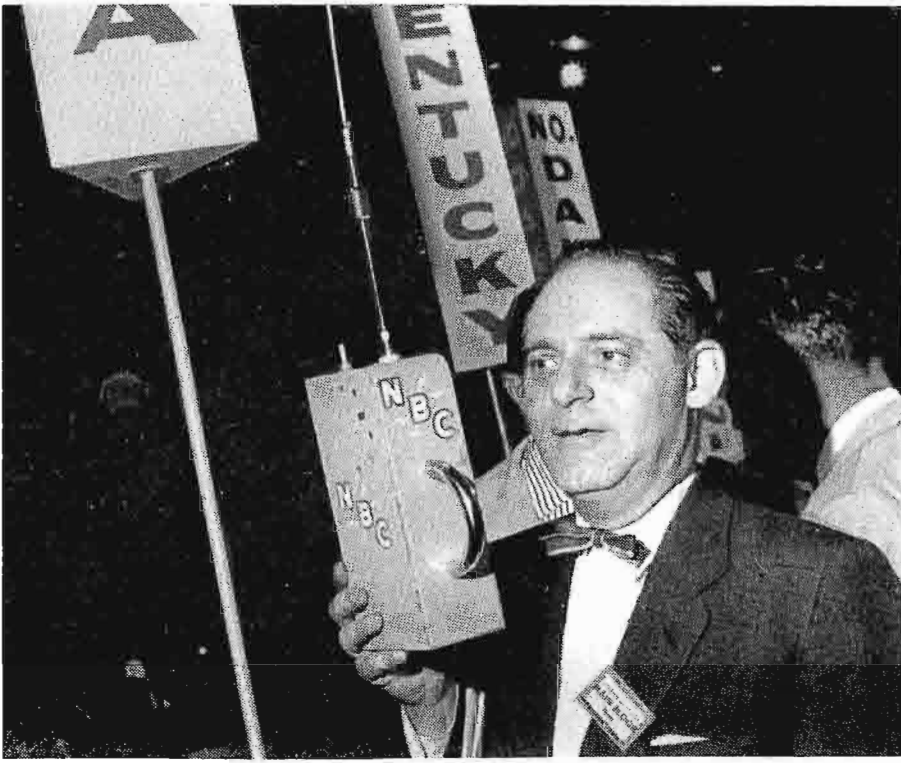

FIG. 6. Two of these ultra-portable TV cameras with one-inch vidicon gave excellent picture quality to on-the-spot action close-ups at the convention. The camera, containing an electronic view finder, weighs about eight pounds and can be either cable or RF-connected. All necessary power and transmitting equipments are contained in the 45-pound "pack." The crystal-controlled transmitter will transmit a composite signal within a bandwidth of approximately 12 mc centered at 2,000 mc. The "miner's light" (right), supplying about 25 foot-candles of light on close-ups was most helpful in places like dimly lit hotel corridors.

FIG. 5. Coverage of the many motorcades from the airport and the center of town to the Cow Palace was provided by this special traveling mobile unit with microwave facilities. Strategically located microwave installations along the route (see dishes at upper left) relayed the mobile unit signal to the control room. Reception was good despite the hilly nature of the terrain. A very interesting effect was achieved by this method when President Eisenhower boarded his special train after he had left the convention activities in San Francisco—watching the train leave seemed to represent the end of the convention story.

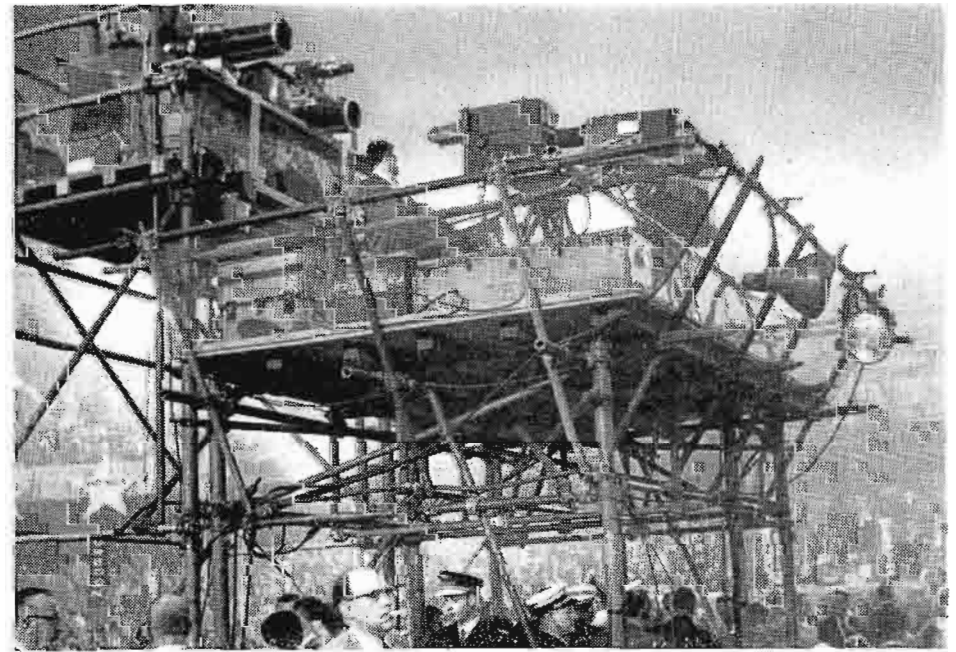

FIG. 7. Democratic National Convention TV "Pool" pickup in Chicago, which all networks used, was the responsibility of NBC. The "Pool" camera platform was located in the middle of the convention floor.

FIG. 8. NBC commentator interviewing James Roosevelt, using a custom-built FM transceiver for the audio pickup. The transceiver consists of an all-transistorized superheterodyne receiver and a two-tube transmitter. This unit, complete with battery and accessories, weighs 29 ounces.



FIG. 1. Main entrance to the WFLA downtown studio building, housing offices, television and radio studios. The 36,700 sq. ft. building occupies an entire city block in an uncrowded area.

WFLA

Television

and Radio

Facilities

by J. H. MITCHELL, *Chief Engineer*, and R. H. MARCHMAN*

George W. Harvey, Vice-Pres.
and Gen'l Manager, WFLA.

J. H. Mitchell,
Chief Engineer, WFLA.

R. H. Marchman, Assistant
Chief Engineer, WFLA.

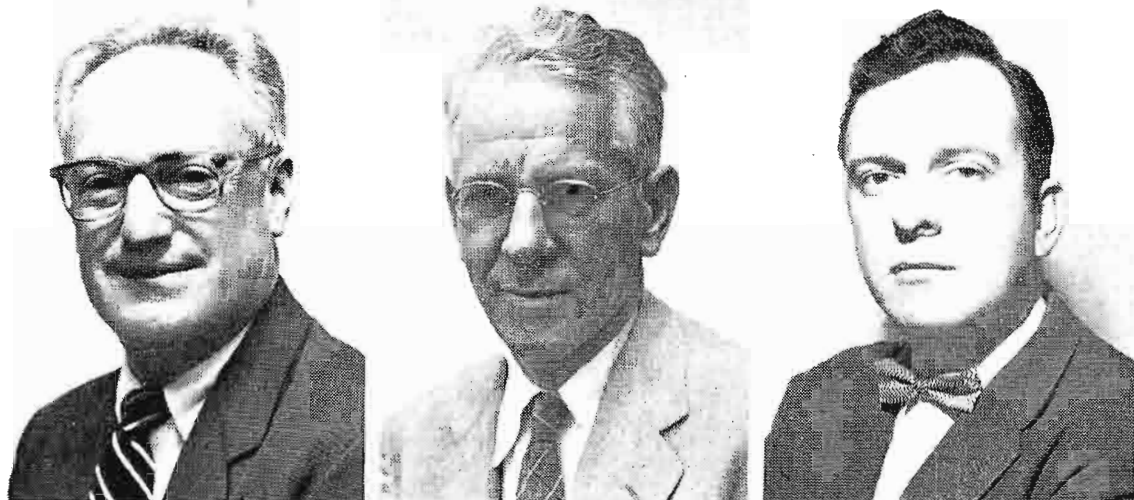

Station WFLA-TV was one of the first major city stations to be planned after the "freeze". The concept of what we wished to accomplish was based on public service, and projected on a long-term basis. This meant an extensive physical "plant"—not merely to do today's job, but to enable us to accomplish our commitments on a larger and more lavish scale. As a result of this concept, WFLA could be transplanted today into markets many times the size of Tampa, and have sufficient facilities to handle the program schedule. From the beginning, our 18-hour-a-day operation included originating over 110 live productions weekly (exclusive of live commercials in film program). This is done with ease, due to our functional planning.

Under the able direction of George W. Harvey, General Manager, who had gone through all the formative years of WGN-TV, we studied existing stations and selected those features we felt would be advantageous. Then we formulated our own floor plan, which, at a later date, was given to an architect for formal drawing. In the same way, we decided upon our physical equipment, working with the assistance of the RCA Engineering Department. We decided on the equipment necessary to do the job. We are happy to state that our final results have lived up to expectations.

Plans for the television station extend back several years prior to receiving the construction permit in August, 1954. During the intervening years, television made great progress and WFLA's planning kept up with this progress. The final planning was carried out over a period of approximately two years before construction was completed in early 1955.

The WFLA-TV transmitter first went on the air with test pattern and full power of 316 kw on January 29, 1955. The first program was a remote pickup of the Gasparilla Parade on February 14, which was the first time this colorful parade had ever been televised. On February 28, we carried our first color program from NBC.

TV and Radio Studios Under One Roof

Knowing first-hand the expense of operating two separate transmitter plants, it was an easy decision to include radio and television studios and offices under the same roof. We were most fortunate in finding a site of 36,700 sq. ft., occupying approximately an entire block. It is four blocks removed from the main downtown area, easily accessible and yet away from crowding.

* Now with RCA Broadcast Studio Engineering.

Under conditions peculiar to Florida climate and living, we constructed a reinforced concrete block two-story building of 26,400 sq. ft. All studios, prop rooms and offices are on the ground floor, with dressing rooms, auditing office, audition and viewing rooms and office supply storage on the second floor. The layout includes an outdoor studio and private parking for 40 automobiles.

Studio Operating Area

The arrangement of WFLA's TV studio operating areas and facilities were dictated by:

- (1) The programming requirement of being able to rehearse one live show while another live show is on the air, and
- (2) The desire to be able to maintain maximum efficiency.

The first requirement was satisfied by providing two production or studio control rooms, one overlooking each of the two largest and most widely used studios (studios "A" and "B").

The second requirement was satisfied by concentrating all of the technical equipment possible in a master control room. This master control room contains camera controls for all cameras, both film and live, and a complete audio-video switching system in the form of a combined TC-4A and TS-5A.

Thus, during times when no live studios are in use (operating network and film only) the operation of the station falls upon three men; the transmitter operator; MCR operator; and projectionist. In an emergency, the operations of the projectionist and MCR operator could be performed by one man by use of projector remote controls located in MCR. The projection room is adjacent to MCR, with access provided by a door between the two.

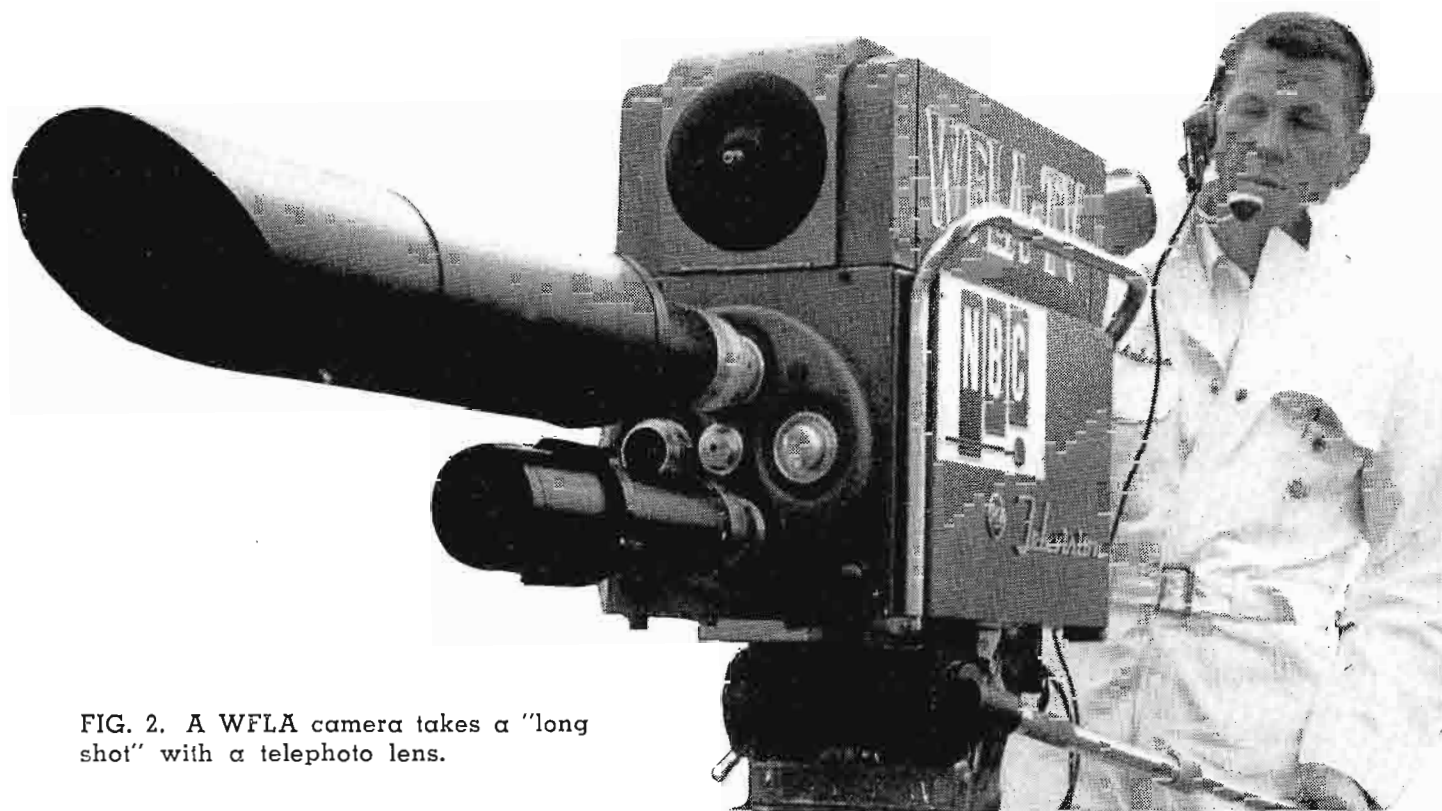

FIG. 2. A WFLA camera takes a "long shot" with a telephoto lens.



FIG. 3. Another remote, "The Gasparilla Parade" is an annual Tampa festival commemorating José Gaspar, a colorful pirate adopted as Tampa's patron rogue.

FIG. 4. WFLA is quite aggressive in the field of remotes. This sequence of shots, tying in with the cover of this issue, shows how one big job was handled. WFLA originates many sequences from the Florida Wonderlands for "Wide-Wide-World."





FIG. 5. Auto commercial takes place in studio "A". Ample access to this studio provides simple mobility of large objects.

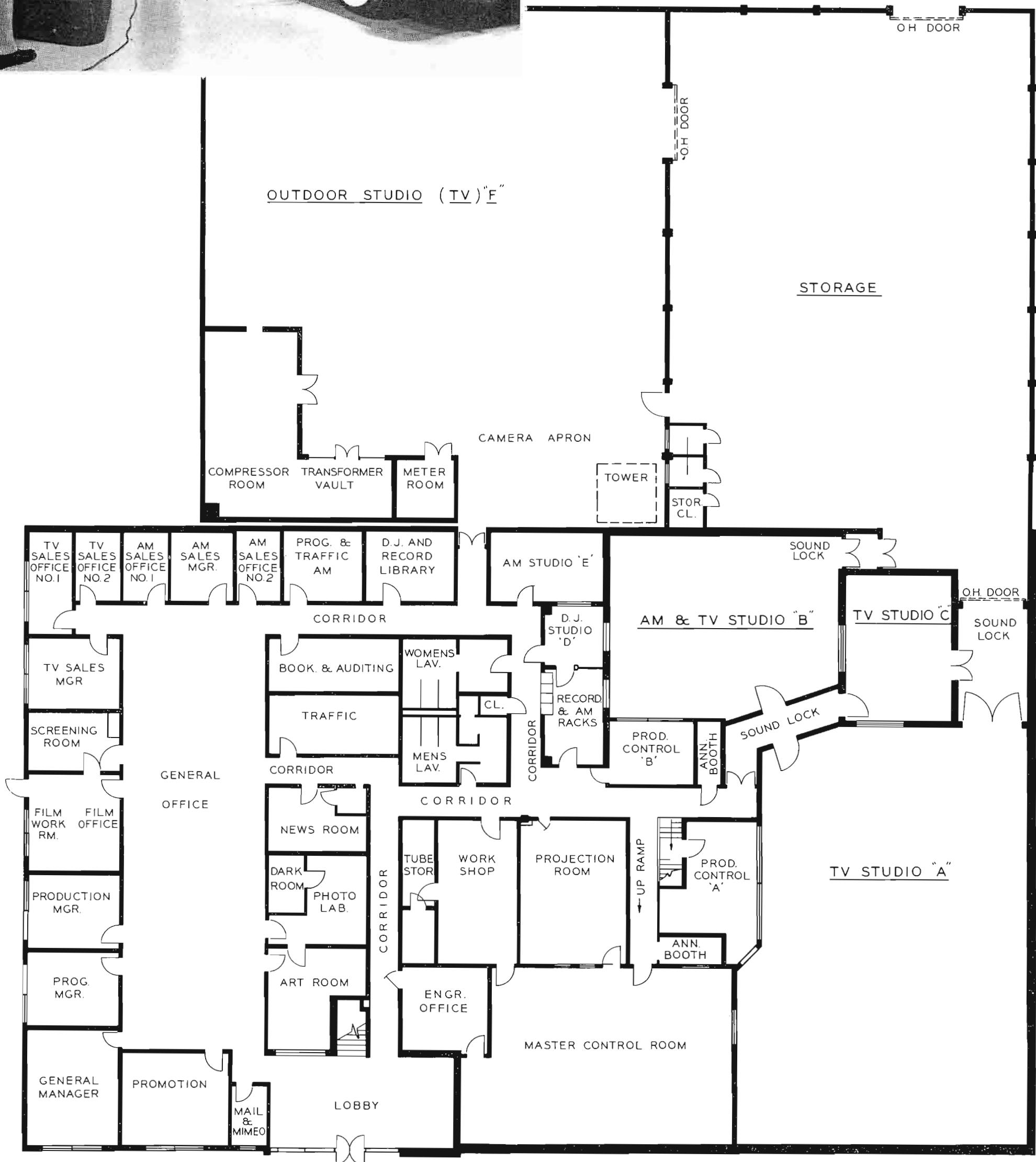

FIG. 6. Floor plan of downtown studio building showing layout of all studios (both radio and TV) offices, and departments.



FIG. 7. Studio "A" showing: kitchen with "roll-away" stove, control room on right, clients' observation room upper right, clients' audition room to left of observation.

Each production control room contains only an audio console with associated pair of turntables, a video switcher and 17-inch picture monitors for each picture source feeding the switcher, as well as switcher output and MCR line output.

Thus either control room and studio may be placed in live operation by activating a production group consisting of a program director (who does his own video switching), his floor assistant, and four operators as follows: audio operator, microphone-boom operator, and two cameramen. Both control rooms and studios can be placed in operation simultaneously by activating two production groups. Under these conditions, a video operator is ordinarily assigned to assist the MCR operator in shading the four live cameras and two film cameras.

Other features which provide for a completely flexible and efficient operation include the following:

- (1) A camera cable patch panel permits patching any combination of the four live camera controls to camera cable receptacles located in the four studios. Thus all four cameras may be used in studio "A", or two in studio "A" and two in studio "B", etc.

- (2) The three indoor studios ("A", "B" and "C") are adjacent to a common sound lock. This permits back-to-back shows from different studios to be easily handled from one control room by one production group. Thus, only one pair of cameras is used by dollying the cameras between studios during the station break. Small notches have been provided in the bottom of the three doors entering the sound lock to permit the passage of the camera cables. since for this application, time would not permit re-patching the camera cables.
- (3) Each of the audio consoles is provided with a microphone selector switch which permits four of the microphone inputs to be switched to any one of the four studios at will. It also switches the speaker interlock, "Rehearsal" and "On Air" tally light to the appropriate studio.
- (4) Duplicate lighting control panels for studio lighting are located in the control rooms. This permits the cameramen to conveniently set the lights prior to the broadcast. Then, if desired, the program director can control the dimmers and contactors

from his position in the control room without requiring that an operator be stationed at the studio lighting panel.

- (5) All four television studios are adjacent to the prop storage area. Thus, every effort has been made to provide for an efficient operation, and a truly flexible arrangement. As many as three programs may be carried on simultaneously from the three control rooms, for example, two live rehearsals from control rooms A and B while network or film is on the air via MCR.

Remote Pick-ups

Because of the heavy schedule of remote pick-ups, it became necessary to add two additional TK-31A field cameras so that as many as four cameras can be used on one remote as is frequently required for network programs and at other times allowing two cameras to remain on the remote truck with four cameras available for studio programs.

Studio "A"

Studio "A", 50 by 70 ft., is the largest and most widely used of the three indoor television studios. The larger production

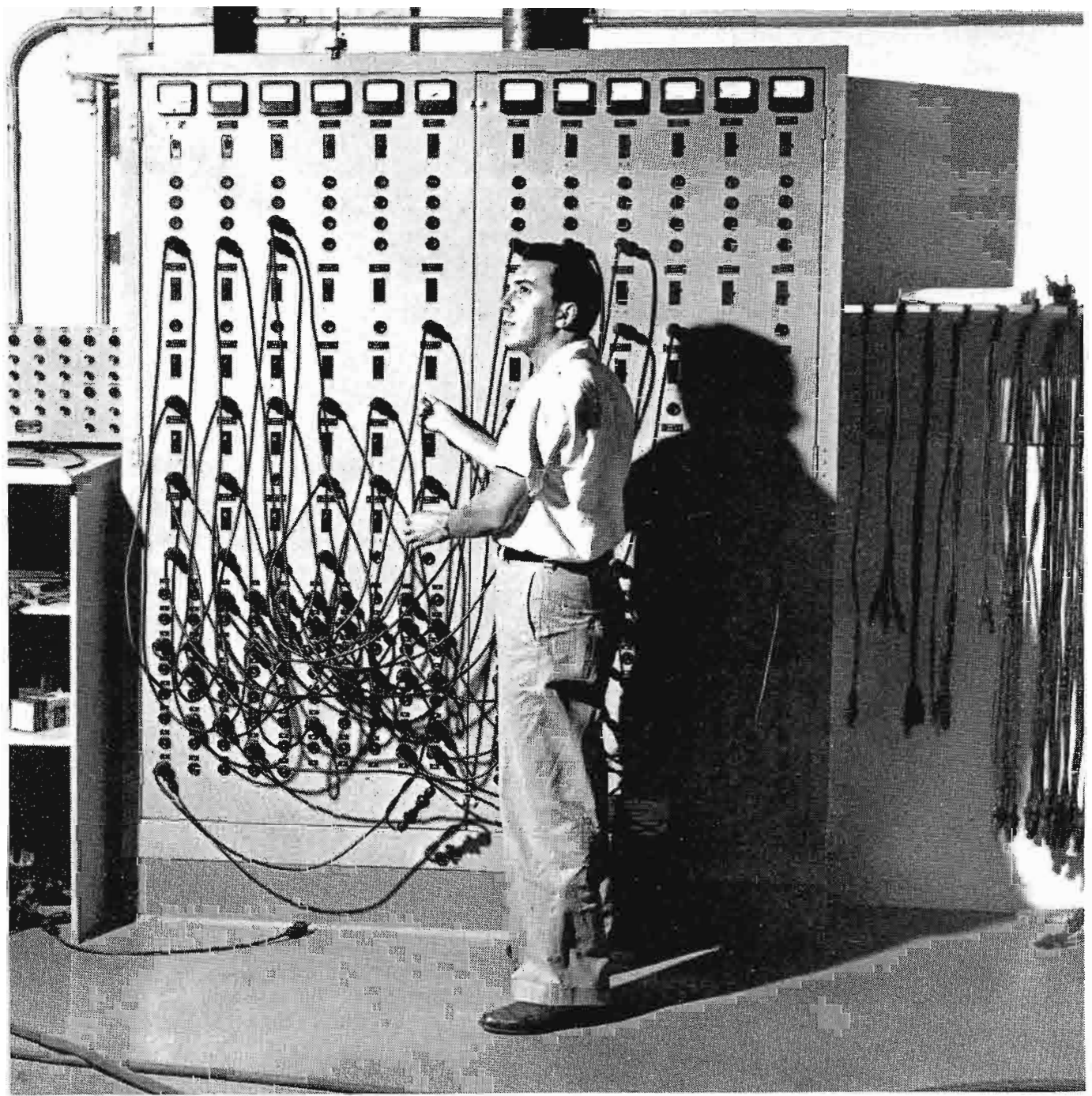

FIG. 8. Lighting panel in studio "A".

control room and MCR overlook this studio. Also overlooking this studio from the second floor are two public rooms, a client viewing room, and an audition room. There is a door through a sound lock into the prop storage area, large enough to permit automobiles to pass. There is a catwalk around three of its walls. The studio includes a complete operating kitchen.

Studio "A" Lighting

A fixed lighting grid, 15½ ft. above the studio floor (maximum scenery height) covers the entire studio. It is constructed of 1½-inch pipe on 8-foot centers. Above this grid are air conditioning ducts, work lights, and wiring ducts upon which are located 100 lighting receptacles.

The lighting control equipment for studio "A" (and "B") was custom built to our specifications. The main feature is the use of duplicate remote control panels; one in the studio and the other at the program director's fingertips in the control room. This permits the lighting patch panel to be located in the studio which facilitates setting up the lights, while the program director may control the lights during the broadcast.

Push buttons on the remote control panels operate eight mechanically-latching contactors. Four of these supply power to four groups of "non-dimmable" source re-

ceptacles on the patch panel. The other four supply power to four motor-driven variable auto-transformers, which in turn supply "dimmable" source receptacles on the patch panel.

The patch panel is located in the studio, while the contactors and auto-transformers are located elsewhere to prevent their operating noise from entering the studio. Each of the four "non-dimmable" groups supplies twelve source receptacles, fed through 20-ampere breakers. Each of the four "dimmable" auto-transformers supplies three breakers rated 20 amperes, then to source receptacles. Thus, a total of 1,200 amperes is available for lighting studio "A", which is sufficient for either monochrome or color.

This power can be patched at will to the 100 branch receptacles located above the lighting grid, 25 on the catwalk and 25 along the walls near the floor. Also provided along the walls are three 50-ampere range outlets which may be used not only for appliance demonstrations, but also for lighting equipment requiring above 20 amperes, for example, spot, rear screen projector, etc.

Studio "A" Audio/Video Receptacles

Also located in studio "A" are camera cable receptacles for 4 live cameras returning to the camera cable patch panel in

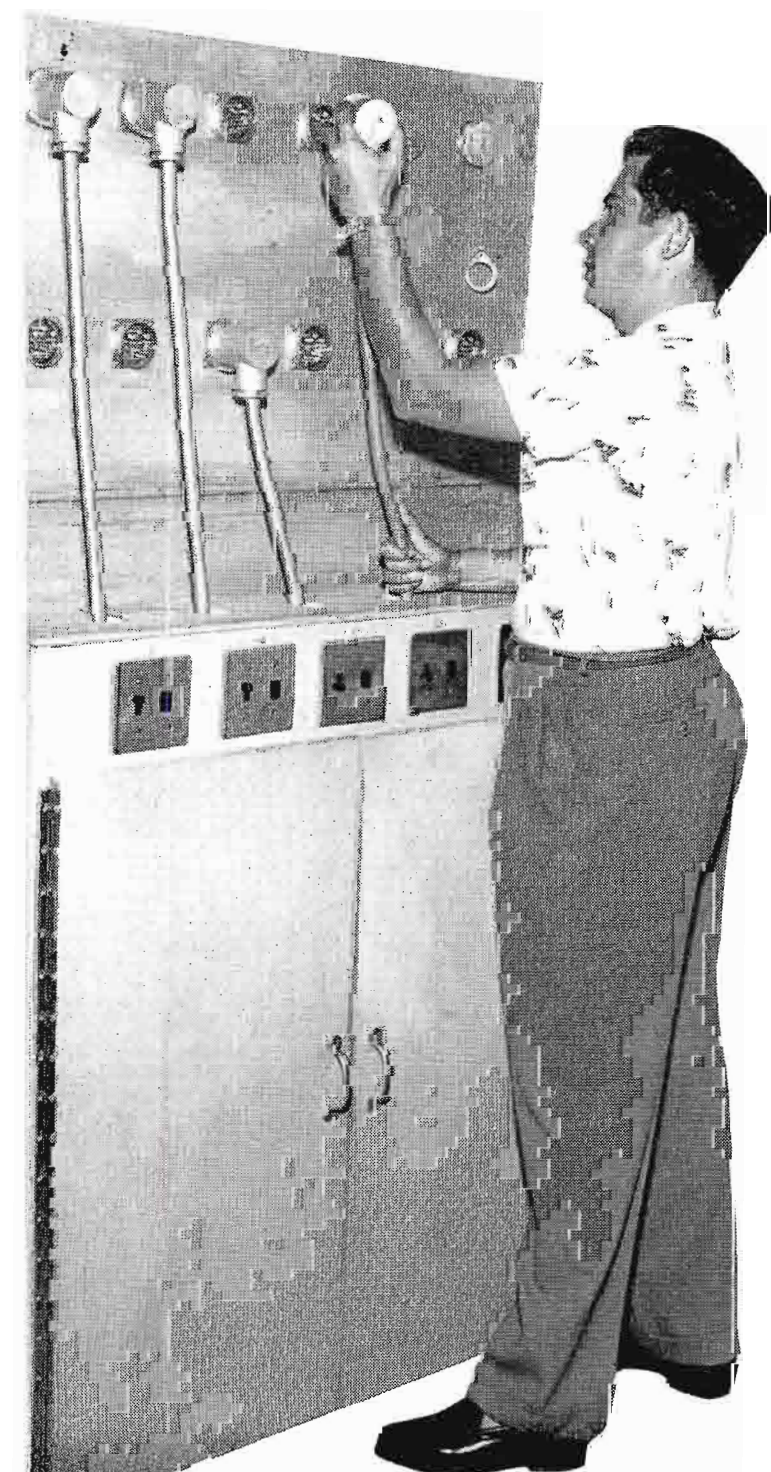

FIG. 9. Camera patch panel, with inputs to four camera controls and twelve sources with power on-off switches and tally lights.



FIG. 10. Studio "A" production control room, larger of two control rooms. Elevated three feet to effect good visibility. Twenty-foot control desk extends full width of room. Equipment looking from foreground consists of: lighting remote control, intercom control, TS-20A Video switcher, TG-15A special effects, BCM-1A mixer, BC-2B consolette, tape recorder and play back.

MCR, 16 microphone receptacles to the studio "A" audio console, 4 microphone receptacles to the studio "B" audio console, headset jacks, cue headphone jacks, dial telephone jacks and utility picture monitors.

Studio "A" Control Room

This is the larger of the two control rooms. It is elevated 3 ft. to effect good visibility throughout the entire studio. Also visible to the right of the operators in this control room is studio "J" (announce booth). Beneath the window 11 monochrome monitors are located. These present all video sources feeding the switcher, the output of the switcher, and the outgoing line. Picture sources presented by these monitors include four live cameras, two film cameras, network, remote and special effects.

A 20-ft. control desk extends the full width of the control room. Behind this desk are seated the program director and the audio operator. If the show is complex, an assistant to the program director may be assigned to do the video switching. Equipment arrangement is as follows: Lighting remote control; intercom control; TS-20A video switcher; TG-15A special effects; BCM-1A auxiliary microphone mixer; BC-2B audio consolette, playback loudspeaker control; tape recorder; and a pair of turntables.

Two of the five output banks of the TS-20A relay video switching system are used to feed a TA-10A mixing amplifier and hence to a TA-7B stabilizing amplifier. The push buttons for these two fader banks as well as the fader levers for the mixing amplifier are located in the control desk in control room "A". Two other output banks of the TS-20A also have their controlling push buttons located in this control desk. These two banks are used to feed signals to the TA-15A special effects amplifier. The output of this amplifier appears on the No. 12 input position of the TS-20A, thus permitting the director to fade into the special effects amplifier output. A simplified control panel has also been installed adjacent to the TG-15A chassis in the MCR rack to facilitate adjustments to the TA-15A and TG-15A during set-up and maintenance. The fifth output bank of the TS-20A is used to feed the MCR TM-6B prevue monitor. Its controlling push buttons are located in the MCR console.

The BCM-1A is operated in conjunction with the BC-2B, providing 12 additional microphone receptacles in studio "A". The four microphone positions provided by the BC-2B may be switched to studios "A", "B", "C" or "F" by means of a four-position microphone location selector switch. The audio tally light and loudspeaker

interlock information are also switched to the proper studios by this same switch. The No. 4 microphone input to the BC-2B may be switched not only into the studio, but also to the output of the microphone in announce booth, and to a microphone in control room "A". This switch is normally in the announce booth position.

Remote audio sources distributed to the audio consolette in control room "A" include network, remote, film projector No. 7, film projector No. 8, tape recorder and tone. Two turntables operate in conjunction with the BC-2B audio consolette, as well as feed the selector switch of the studio "A" playback loudspeaker control unit. This control unit consists of a ten position selector switch which connects a bridging coil to any desired audio source. The output of this bridging coil feeds through a variable attenuator to a BA-14A monitoring amplifier, thence into a playback speaker in studio "A".

This playback speaker, unlike the regular program and intercom speakers, is not interlocked with the microphone key switches on the audio consolettes. This permits recorded material from disc and tape to be played back into the studio while microphones are on. This is accomplished without danger of feedback through the BC-2B mixer networks by a suitable arrangement of isolation amplifiers.



FIG. 11. Studio "B" showing both television and radio control rooms. The small window on the left behind the camera is "H" Announce Booth. The large window to the left of center looks into "B" studio television production control room. The smaller window just to the right of television control room looks into radio control with an RCA 76-C audio console and rack equipment in the background. The window on the extreme right looks into radio announce booth with an RCA BC-2B console. A 44BX mike and a tape recorder being visible in front of the announcer. "On Air" lights above each of the television and radio control room windows are operated from their respective control points. There are microphone outlets in this studio from both television control rooms as well as radio control.



FIG. 12. Property room showing auto drive-in door at rear.

Studio "B"

Studio "B" is 39 by 31 ft. and the second most frequently used studio. It is overlooked by control room "B", the public viewing room, and by our radio control room and recording room. Studios "B" and "C" are used in our radio operation whenever the occasion requires a larger area. When used for radio and recording work involving music, reverberation is improved by proper placing of readily available TV scenery.

Studio "B" Lighting

Studio "B" lighting grid is the same as studio "A", being 1½-inch pipe on 8-ft. centers, 15½ ft. above the studio floor. The lighting control panel is the same as that in studio "A" except that it has exactly half its capacity. It incorporates two "non-dimmable" groups and two "dimmable" auto-transformers supplying 600 amperes to 75 branch receptacles; here again sufficient for color as well as monochrome. Duplicate remote control panels are provided in the studio and control



FIG. 13. View of studio "B" production control with announcer's booth in the background. Desk equipment in this control room is similar to that of control room "A", permitting familiarity when operators and directors switch from one room to the other.

room. Two 50-ampere range outlets are also provided.

Studio "B" Audio/Video Receptacles

There are camera cable receptacles for 3 live cameras returning to the camera cable patch panel in MCR. There are 4 microphone receptacles to the audio console in control room "B", 4 to the console in control room "A", and 4 to the radio control and recording control room. In addition, there are jacks for headsets, cue headphones, dial telephones, and utility picture monitors. This studio also has a large door opening through a sound lock into prop storage. It includes necessary plumbing and electrical facilities to permit installation of an operating kitchen.

Studio "B" Control Room

The layout and equipment arrangement for control rooms "A" and "B" were made similar to permit directors and operators to interchange control rooms without experiencing any difficulty. The main difference is in the type of video switching equipment employed. Control room "A" features fading and special effects in the form of a TS-20A relay switching system,

while control room "B" features fading in the form of a TS-11A mechanical switching system.

Beneath the window, overlooking the studio 8 monochrome monitors are located. Picture sources presented include 2 live cameras, 2 film cameras and network. The control desk contains the following: lighting remote control; intercom control; TS-11A video switcher; BC-2B audio console; playback loudspeaker control; a tape recorder; and a pair of turntables. The inputs of the TS-11A video switcher are fed the four live cameras, the two film cameras, network and remote.

Program types thus far handled by this control room have not necessitated more than the 4 microphones accommodated by the basic BC-2B audio console. Therefore, a BCM-1A auxiliary microphone mixer is not presently installed in the control room, although space has been provided for its ready inclusion.

The microphone location selector switch in control room "B" permits the 4 microphone inputs to the BC-2A in the control room to be switched at will to receptacles

in studios "A", "B", "C" or "F". Again the audio tally lights and speaker interlocks follow the microphone location selected. Microphone input No. 4 may be switched from studio to announce booth ("H") or to control room "B". It is normally in the announce booth position.

The remote audio sources feeding the audio console are identical to those simultaneously distributed to control room "A". The studio "B" playback loudspeaker control unit operates in the same manner as that of studio "A".

Studio "C"

Studio "C" is the smallest of the three indoor TV studios, being 18 by 25 ft. It was designed to accommodate two semi-fixed news or interview type sets on two adjacent walls. A pulley arrangement on the roof joists along these walls permits flying scenery along the walls.

A loft along the opposite walls permits some scenery storage. Immediately beneath the loft at about 12-ft. from the floor a lighting grid is located consisting of 1½-inch pipe on 4-foot centers.

Simple lighting power distribution is provided by two standard breaker panels, each containing twelve 20-ampere breakers wired directly to receptacles on the grid and walls. Also provided is one 50-ampere range outlet for operation of a 5,000-watt rear screen slide projector.

Along walls opposite to those upon which the scenery is placed are the walls of studios "A" and "B". Windows permit cameras to shoot through from either studio, thus permitting scenes in studio "C" to be integrated into a program coming from either "A" or "B". If time permits, cameras may be dollyed through the common sound lock from either "A" or "B" for use in studio "C".

Besides the 2 camera cable receptacles, studio "C" provides 4 microphone receptacles each to control rooms "A" and "B" and 4 to the radio control and recording control room. Also provided are radio and TV cue headphone jacks, utility picture monitor jacks, etc.

Studio "C" has found wide application for radio, recording and filming. It is also used to locate the rear-screen slide projector; this unit projects through the large window into studio "A" where the translucent screen is located. This reduces the floor space required by this equipment in studio "A" as well as eliminating the noise generated by the projector's blower motor.

Air-Conditioning System

The air conditioning system is divided into three units; a 60-ton unit for studio "A", "B" and "C", and control rooms "A" and "B"; a 20-ton unit for the remaining radio and TV operating areas; and a 30-ton unit for the general offices and second floor. The 60-ton unit may be shut down whenever there are no live shows or rehearsals. Likewise, the 30-ton unit may be shut down whenever the general offices are not in use.

Outdoor Studio

Studio "F" is a 78 by 87 ft. outdoor patio adjacent to the street and to prop storage. It is completely enclosed by the building walls on the two sides and by 10-foot high concrete walls on the other two sides. One automobile entrance has been provided in the wall adjacent to the street, and another through prop storage into the street. A concrete deck covers a portion of the patio studio, while the remainder is uncovered. This uncovered area lends itself to acrobatic acts, animal acts and landscaping.

A weather-proof cabinet houses three camera cable receptacles to the camera cable patch panel in MCR, four microphone receptacles each to control rooms "A" and "B" and picture monitor jacks, etc. Around the walls weatherproof 20-ampere lighting receptacles are located.

FIG. 14. Outdoor studio "F" area, showing: circus ring with audience participation. Base of microwave tower visible in right background.





FIG. 15. Outdoor studio, showing circus ring and performers. The outdoor studio is readily converted for any outdoor presentation.

Central Prop Area

Since all four television studios are adjacent, through appropriate sound locks to the 8,400 sq. ft. prop storage area, it is a simple matter to set up and strike sets in a minimum of time.

Cyclorama curtains 10 ft. high have been provided around all four sides of both studios "A" and "B". These curtains are hung from a track which permits them to be readily moved to any part of the studio. The tracks have been mounted a few feet out from the walls to permit certain props and scenery to be stored out of sight temporarily by simply drawing the curtain in front of them. This is also true of the kitchen.

Announce Booths

Studio "H" is the announce booth associated with and adjacent to control room

"B". Glass windows provide visibility into studio "B" as well as the control room. Studio "J", the announce booth associated with control room "A", is located between the control room and MCR. Visibility is afforded by a glass window between this booth and both of these control rooms as well as studio "A".

Like studio "J", the studio "H" announcer's microphone is distributed to the MCR audio switcher as well as the Studio Control Room audio console. This permits the station break announcements to emanate from either announce booths during network and film operation via MCR. This releases the other Announce Studio for rehearsal with its control room.

Both studios are identically equipped including announcer's microphone, microphone operate key switch, intercom and monitor speaker, headphones, utility pic-



FIG. 16. RCA 3-V film system. Open door exposes control panel and camera auxiliary chassis . . . top cover houses optical system. RCA TP-6BC 16mm motion picture projector is shown at right.

ture monitor and announcer's desk. Thus, announcers can operate from either studio with equal ease.

Projection Room

The Projection Room is located adjacent to and is visible from the MCR. This 18 by 24 ft. room has two film chain groups, with sufficient space available to permit ready installation of a third group, either monochrome or color. If more space should become necessary in the future, the adjacent shop can be made available by removing a partition.

At present, the projection equipment includes one TK-21A monochrome film camera operating in conjunction with a TP-11 multiplexer, one TP-6B 16mm film projectors and one TP-3B dual-disc slide projector. This equipment is so arranged as to permit ready installation of another film projector and another slide or opaque projector should future programming require.

A TK-26A color film camera, together with a TP-12 multiplexer accommodates a TP-6BC 16mm film projector and one TP-3C dual-disc slide projector. Again the arrangement provides for ready installation of a second film or slide projector.

The TK-26A camera is used for monochrome operation as well as color. This is provided for by operating a single switch in the TX-1B colorplexer which disables the chroma and burst-adder circuits as well

as switching only the green camera into the luminance channel. By interchanging the positions of the three camera heads periodically, equal use can be made of all vidicons.

Located in the projection room is a cabinet rack in which are housed a film projector cueing amplifier and speaker, film projector exciter lamp power supplies, reactance dimmer and other miscellaneous equipment. On a wall-mounted shelf monochrome picture monitors for the two film cameras and the outgoing line are located. Also mounted on this shelf is an "off-the-air" receiver.

Master Control Room

The Master Control Room is conveniently located adjacent to the engineering shop, and the engineering office. Windows afford visibility into studio "A", studio "J" and the projection room.

The 46 by 30 ft. MCR is arranged to accommodate a control console which may be extended along the entire length of the room. At present, this console is 20 ft. long and consists of: two TK-31A field camera controls and their power supplies; two TK-11A studio camera controls; a preview TM-6B master monitor; and a "line out" TM-6B master monitor. The main switching position consists of: TC-4A audio/video switching; two remote control panels; TK-21A monochrome film camera control; and a TK-26A color film camera

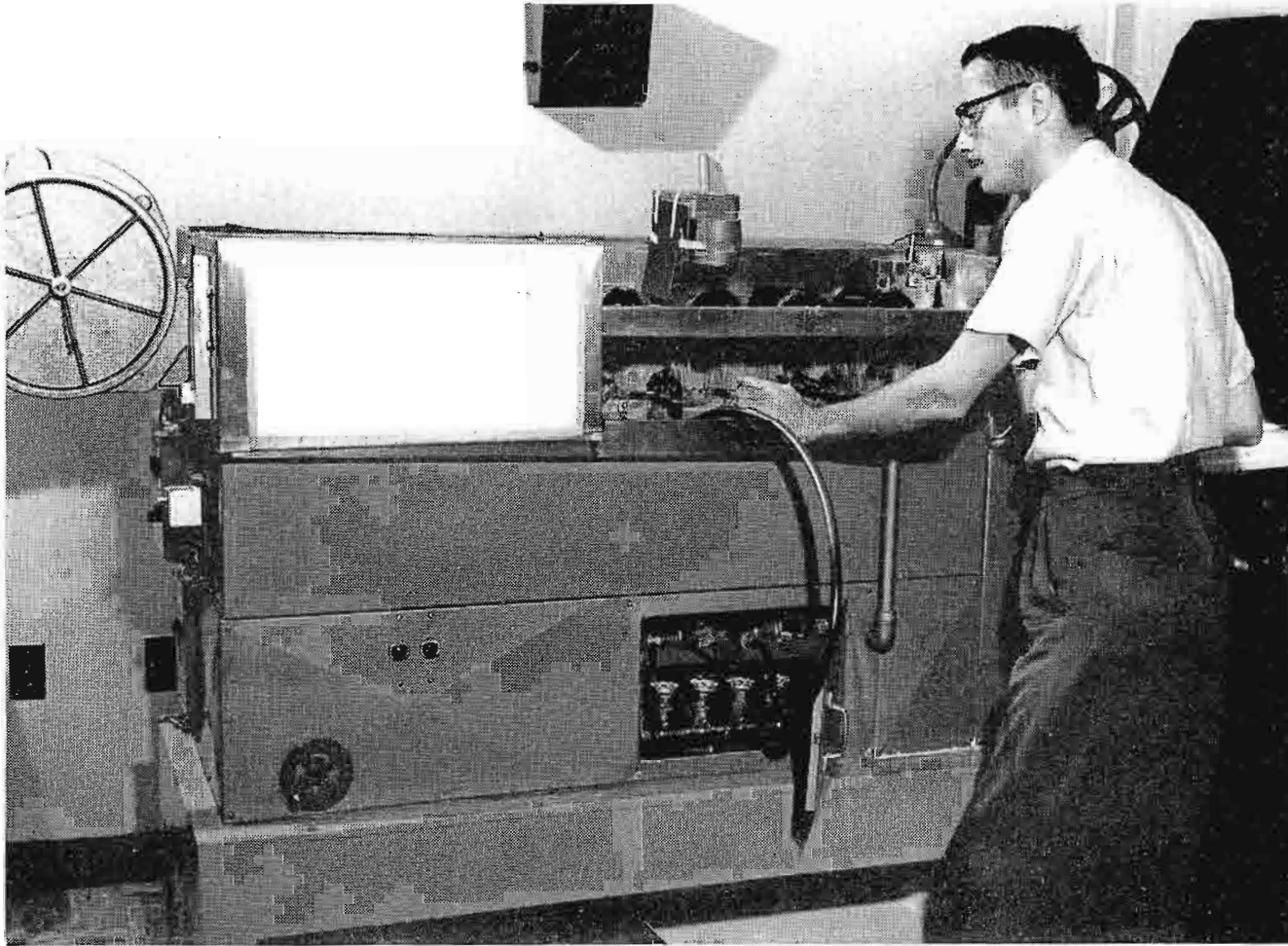

FIG. 17. High speed 16mm film processor. Produces film in a matter of minutes for "on-the-spot" news events and other rush film requirements.

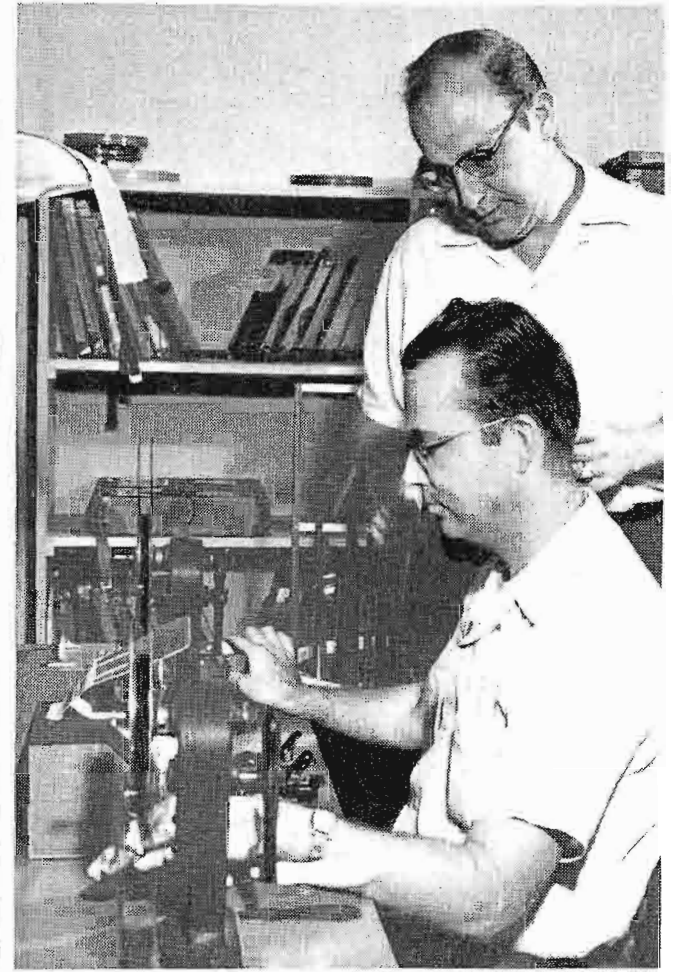

FIG. 18. Efficient film editing set-up at WFLA.

FIG. 19. Film camera control. Monitors at right.



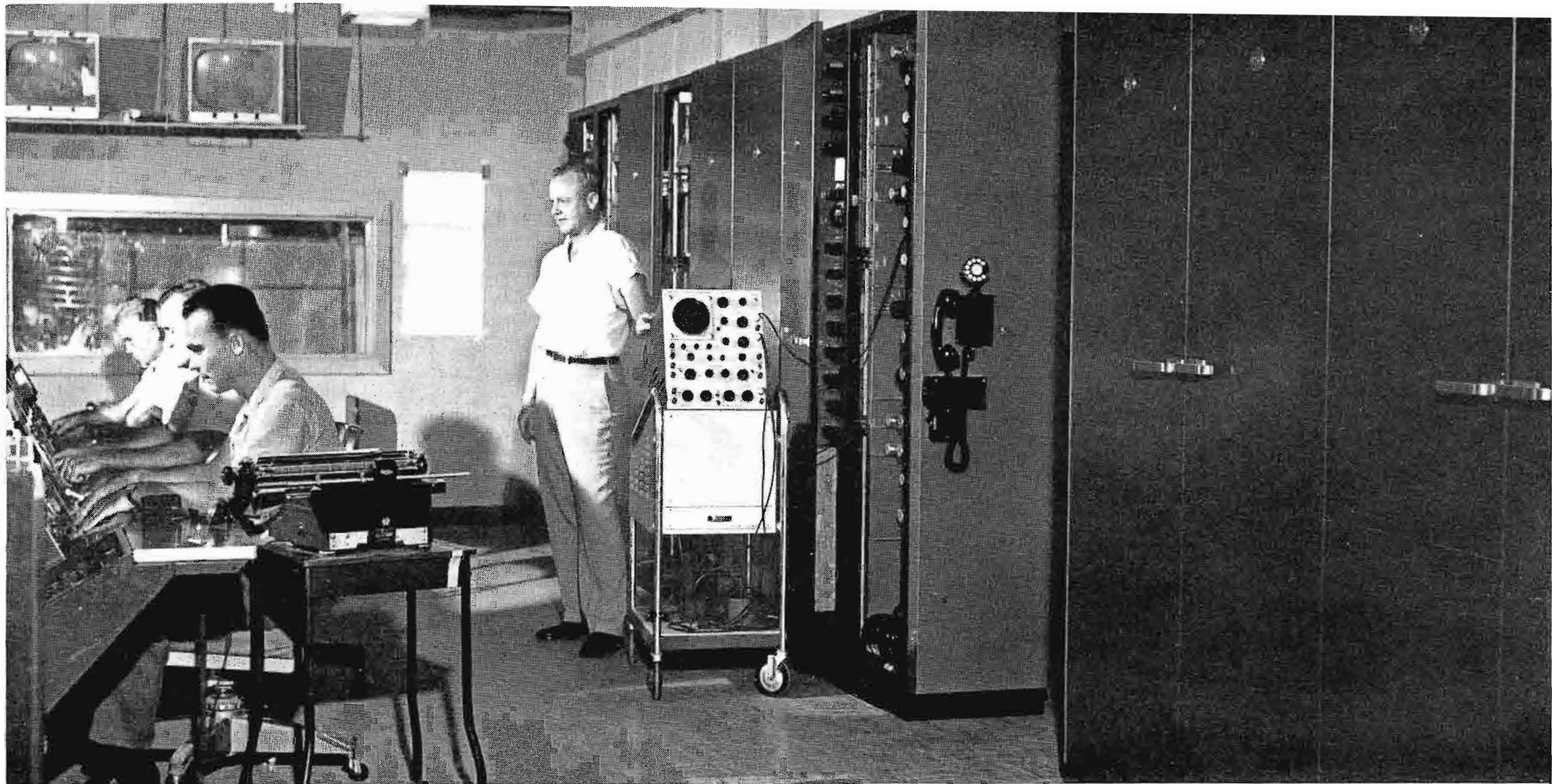

FIG. 20. Television Master Control Room, 46 x 30 ft, arranged to accommodate a control console which may be extended along the entire length of the room. At present, this console is 20 ft long and consists of: two TK-31A field camera controls and their power supplies; two TK-11A studio camera controls; a preview TM-6B master monitor; and a "line out" TM-6B master monitor. The main switching position consists of: TC-4A audio/video switching; two remote control panels; TK-21A monochrome film camera control; and a TK-26A color film camera control.

control. An RCA CT-100 color receiver is jeeped as a film color monitor. Twenty feet is available for future expansion of the console.

Two rows of cabinet racks equipped with front and rear doors are located behind the operator. Forced ventilation provides cooling air from the roof, through filters, and a plenum located at one end of the MCR, into ducts below the entire length of the rows of racks. Air comes up through the racks, into exhaust ducts and out of the building at the roof. On the roof a 4,000 cfm blower is located at the end opposite from the intake duct. Adjustable dampers above each of 38 racks permit adjustment of the air to each cabinet individually. Shields placed between each rack provide control of air to each rack.

The rear wall of the master control room behind the cabinet racks is completely covered with $\frac{3}{4}$ -inch plywood. This permits ready installation of such equipment as power distribution panels, etc., that does not lend itself to cabinet rack mounting.

The camera cable patch panel is located convenient to the studio and field camera controls. The main a-c power switches for these camera chains are located, along with associated tally lights, on this patch panel. The video operator can thus be assured that the power is not

on whenever he patches any of the 4 camera controls to any of the 12 receptacles in the TV studios. Four utility picture monitors on a wall-mounted shelf are used for cue purposes for master-control switching into "remote" signals, i.e., network, remote, control room "A" switcher, and control room "B" switcher. All other picture sources feeding the master control video switcher, can be seen on the monitors associated with their respective camera controls. Other monitors include a monochrome and a color receiver operating "on the air".

A TS-5A switcher is operated in conjunction with a TC-4A switcher to provide the master control video switching. The live cameras are fed into the TS-5A, which in turn is fed into one of the TC-4A inputs, along with the color and monochrome film cameras, network and remote stabilizing amplifier outputs, and studio control switchers.

Although the live cameras are ordinarily switched from either of the production control rooms, this arrangement permits complete switching control in master control over all of the station's video sources. This is particularly useful should a fault develop in the studio video switcher when it is on the air. In this emergency, the MCR operator assumes the switching, with the program director giving switching direction via the intercom.

A stabilizing amplifier input and output video relay switching system permits instantaneous transposition and interchange of all four stabilizing amplifiers. Thus, if trouble should develop in the network stabilizing amplifier, the remote stabilizing amplifier may be substituted for it. In like manner, the stabilizing amplifier used with the TS-20A switcher may be instantaneously substituted for the stabilizing amplifier used in conjunction with the TC-4A and vice versa. A push button switch operates video relays which applies any of the four stabilizing amplifiers, the TS-11A switcher, and a prevue switcher directly to the outgoing line.

The TM-6B prevue master monitor is fed by the combination of a TC-4A monitor switch and one output bank of the TS-20A. (The other four output banks of the TS-20A are employed in the video switcher in control room "A"). This monitor switching combination permits viewing all of the important points in the video system.

The audio and video equipment is the latest RCA design. The stabilizing amplifiers are type TA-7B, the video distribution amplifiers are type TA-3A, both of which are particularly suited for color. Two TG-2A pulse generators along with 14 TA-4A and 2 TA-3A amplifiers are employed for generation and distribution of all monochrome and color pulses.

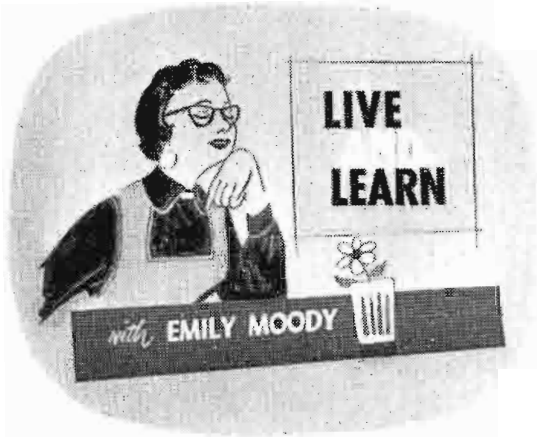
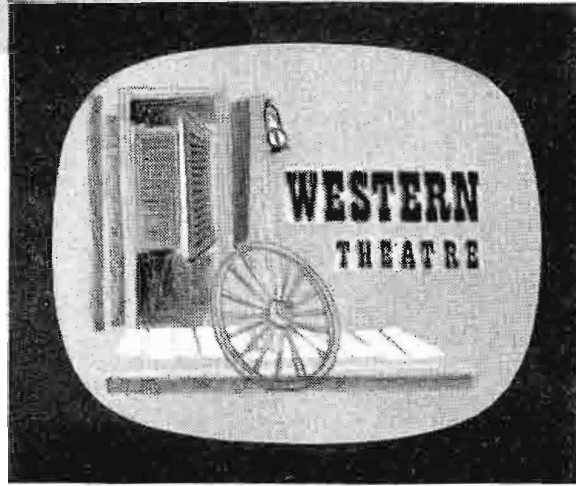
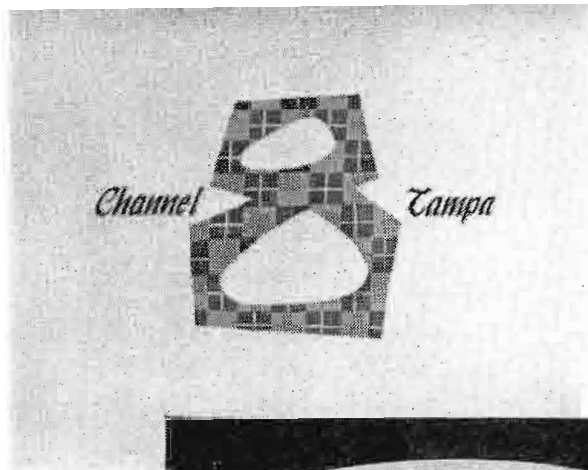

FIG. 21. Title cards and station ID's (left and below) are all done in color.

The WFLA-TV Graphics Department provides a complete expeditious "on-the-premises" service to clients . . . and serves to produce titles and ID's for the station's programming as well.

Art Fairman's art creations are unsurpassed for their originality, simplicity and impact for getting the message across.

Station Manager, George Harvey, decided upon installing this department after reading an article in BROADCAST NEWS (Vol. No. 81, December, 1954) entitled "Preparation of Slides for Color Television."

Other comprehensive information on Television Graphics can be found in BROADCAST NEWS (Vol. No. 75, July-August, 1953 in an article entitled "Television Staging Aids").

FIG. 22. Artist and Graphics Department, supervisor, Art Fairman at work.

FIG. 23. Photo set-up for taking 35mm slides.



FIG. 24. Hot press . . . prints title cards for slides and opaques from regular printer's type quickly and efficiently.

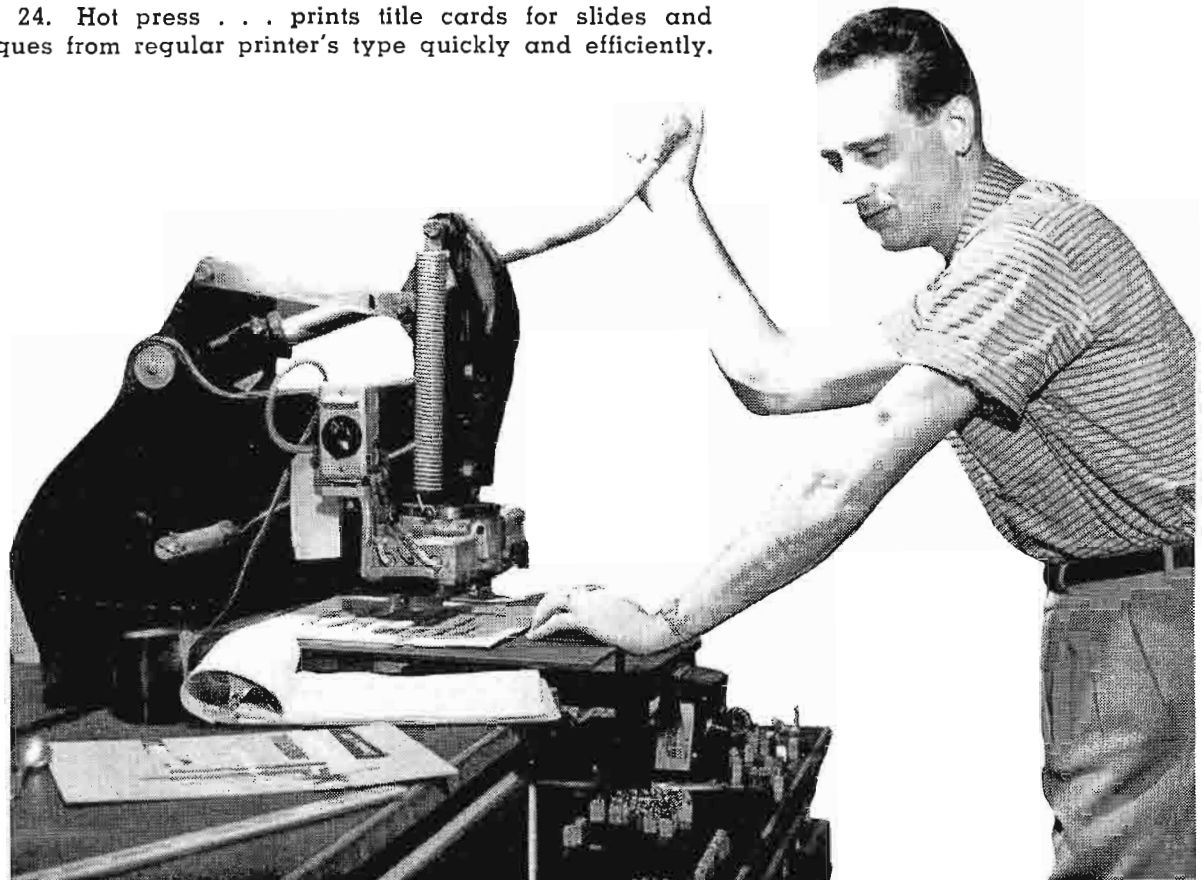
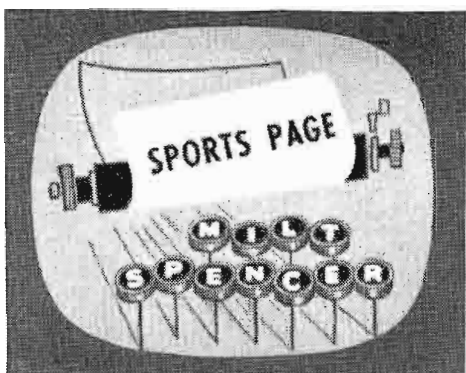
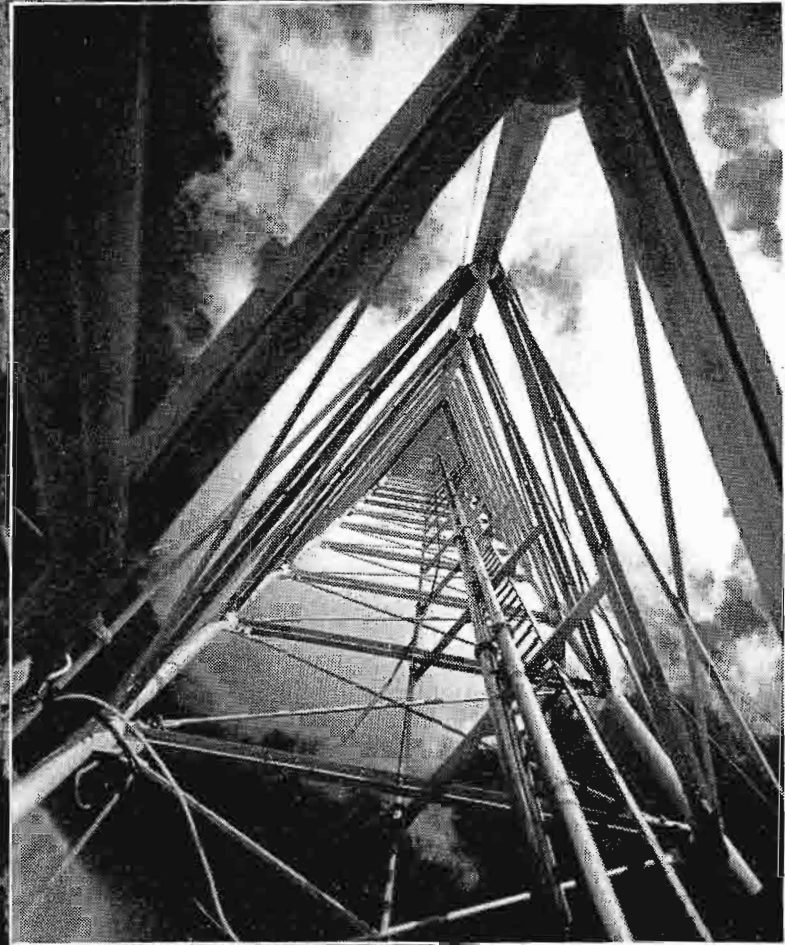



FIG. 25. WFLA-TV tower and antenna point 1055 ft into Florida skies. The Ideco tower structure supports an RCA TF-12AH twelve-section superturnstile antenna. Looking through a picturesque setting of trees bearing Spanish Moss, the transmitter building is visible at the base of the tower.

A "look-up" view of the WFLA-TV tower shows the vertical run of 3 1/8 inch transmission line at the lower right corner.



TV Transmitter and Antenna

The site chosen for our 980-ft. Ideco Tower was a 40 acre tract 14 miles southeast of Tampa. Upon this tower a TF-12AH superturnstile antenna was installed, resulting in an overall elevation above sea level of 1,130 ft. Power and telephone lines had to be constructed for a distance of approximately five miles. Because of the long open-wire power lines and the susceptibility to lightning, two separate sources and lines for power were constructed with automatic switching facilities.

In addition, a 200-kw generator driven by a 330-hp diesel engine furnishes emergency power. This unit is housed in a small Quonset hut separate from the transmitter building. One of the special features of this engine is that the cooling fans are reversed to force air through the radiators and blow the hot air out of the building through louvred openings. This auxiliary power unit is precision regulated to keep the frequency in phase with the synchronizing pulses supplied from the studio over microwave. Also housed in the Quonset house is a 10-kw gasoline-driven generator for emergency tower lighting. It starts and switches automatically upon failure of outside power.

FM Transmitter and Antenna

Our 10-kw FM transmitter was moved to the television site with the FM antenna being mounted at the 900 ft. level on the tower. The resulting improvement in coverage of the FM station enables the station to be received over practically the entire state of Florida.

The transmitter building is of concrete block construction with a prefabricated concrete roof. The transmitter control

room is in approximately the center of this building, with the television transmitter forming one wall, the FM transmitter another wall and the racks forming a third wall, and the fourth wall being the outside wall of the building. The ceiling is a suspended support for acoustical tile and the room is air conditioned for the comfort of the operators. In back of the racks and FM transmitter are the shop, space for storage and the kitchen.

WFLA AM Radio Facilities

Studio "E" is a 12 by 19 ft. radio studio which handles most of our live radio programs. It is adjacent to studio "D" which

actually is an announce booth and control room containing a BC-2B consolette, two 70-C (3-speed) turntables and a tape recorder-playback machine.

Adjacent to studio "D" is the radio control and recording room which contains a 70-C (3-speed) turntables, a BQ-1ATT and a tape recorder-playback machine. and five 9-AX series racks mounting the jack panels, two tape recorders, receivers and amplifiers, etc. This control room overlooks studio "B" which may be used for radio as well as TV programs.

Microphone and remote live inputs to both consolettes are brought up to jacks

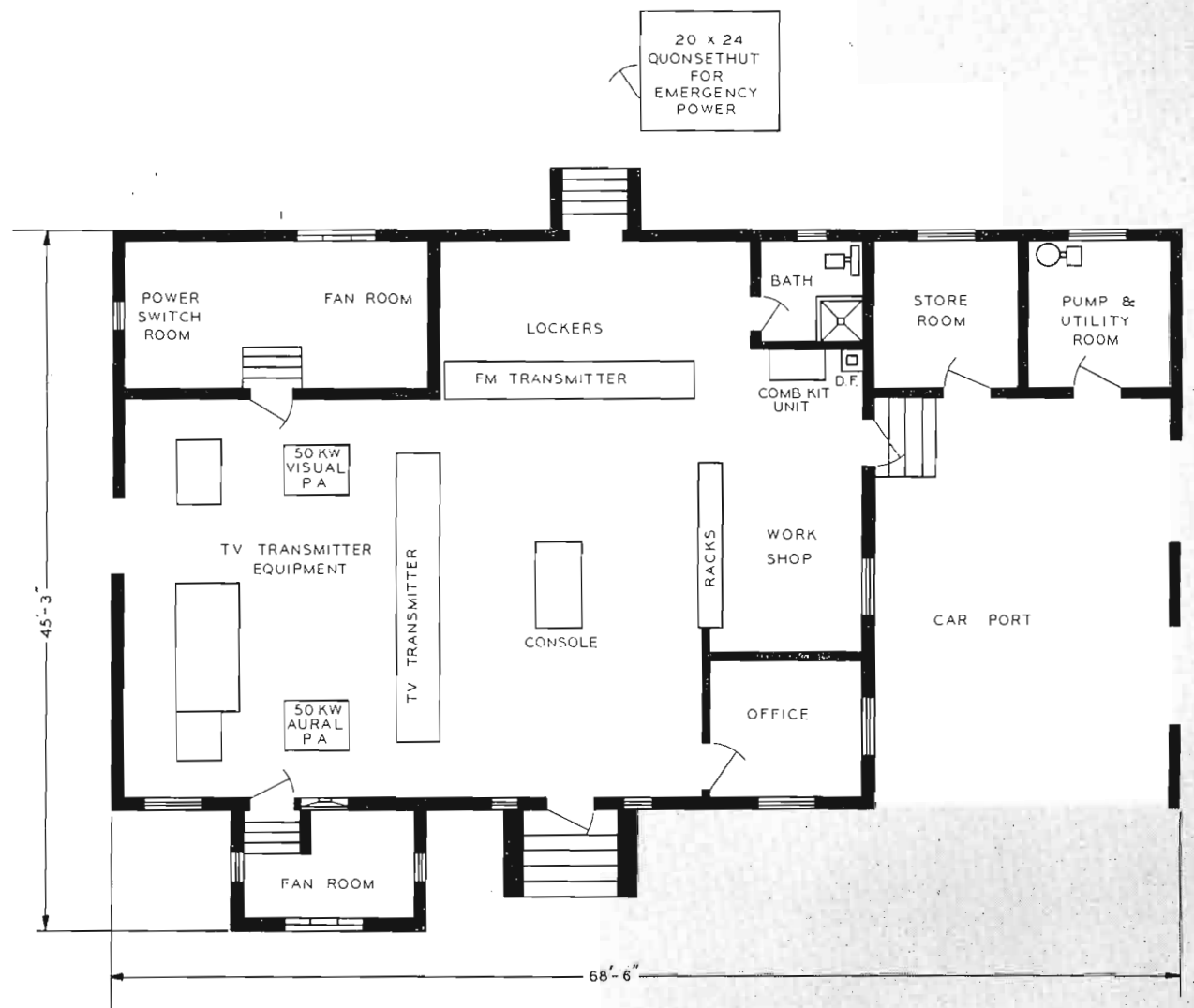
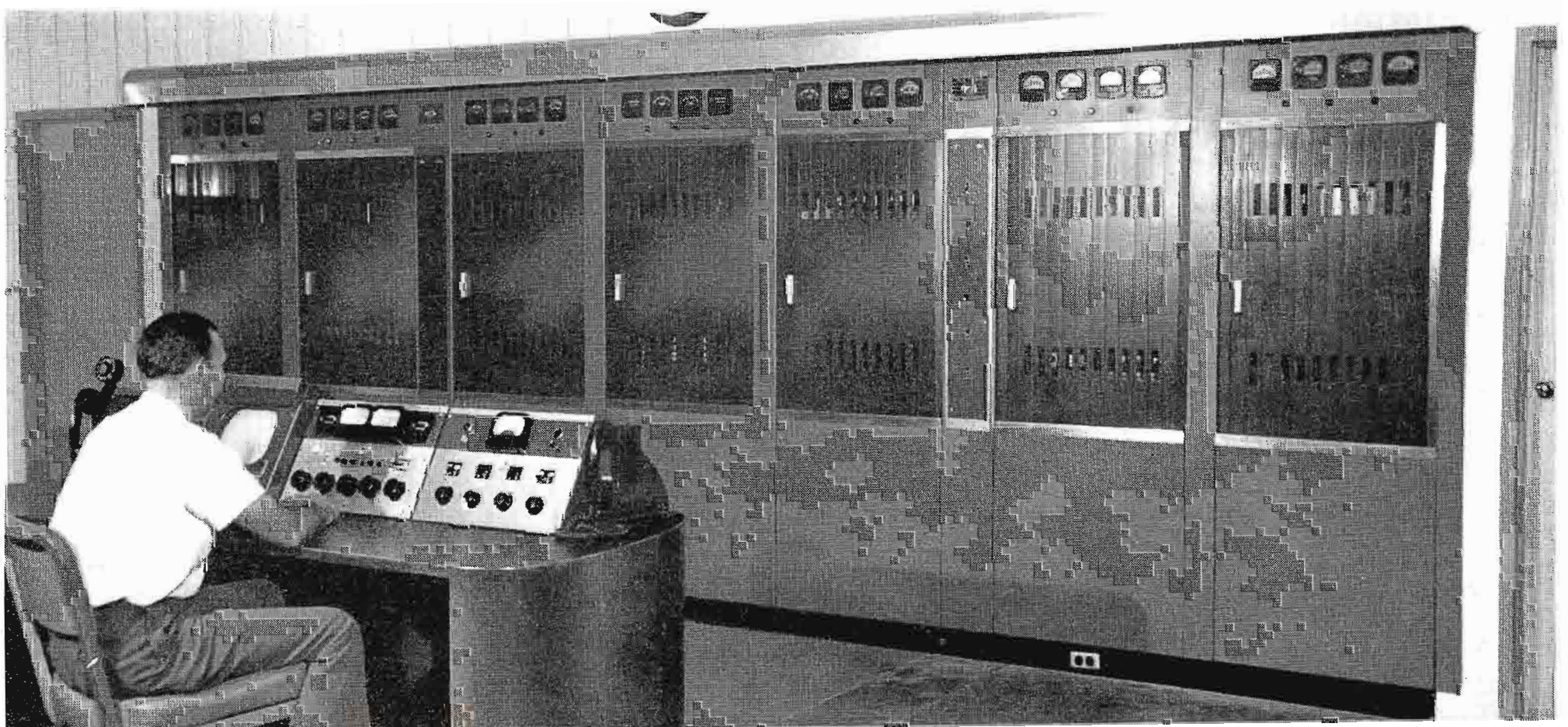

FIG. 26. Floor plan showing layout of television transmitting facilities.

FIG. 27. View of 50 kw television transmitter driver. In the foreground is the television transmitter control console. At the right side of the control console is the FM transmitter control (FM transmitter located in same building as TV).



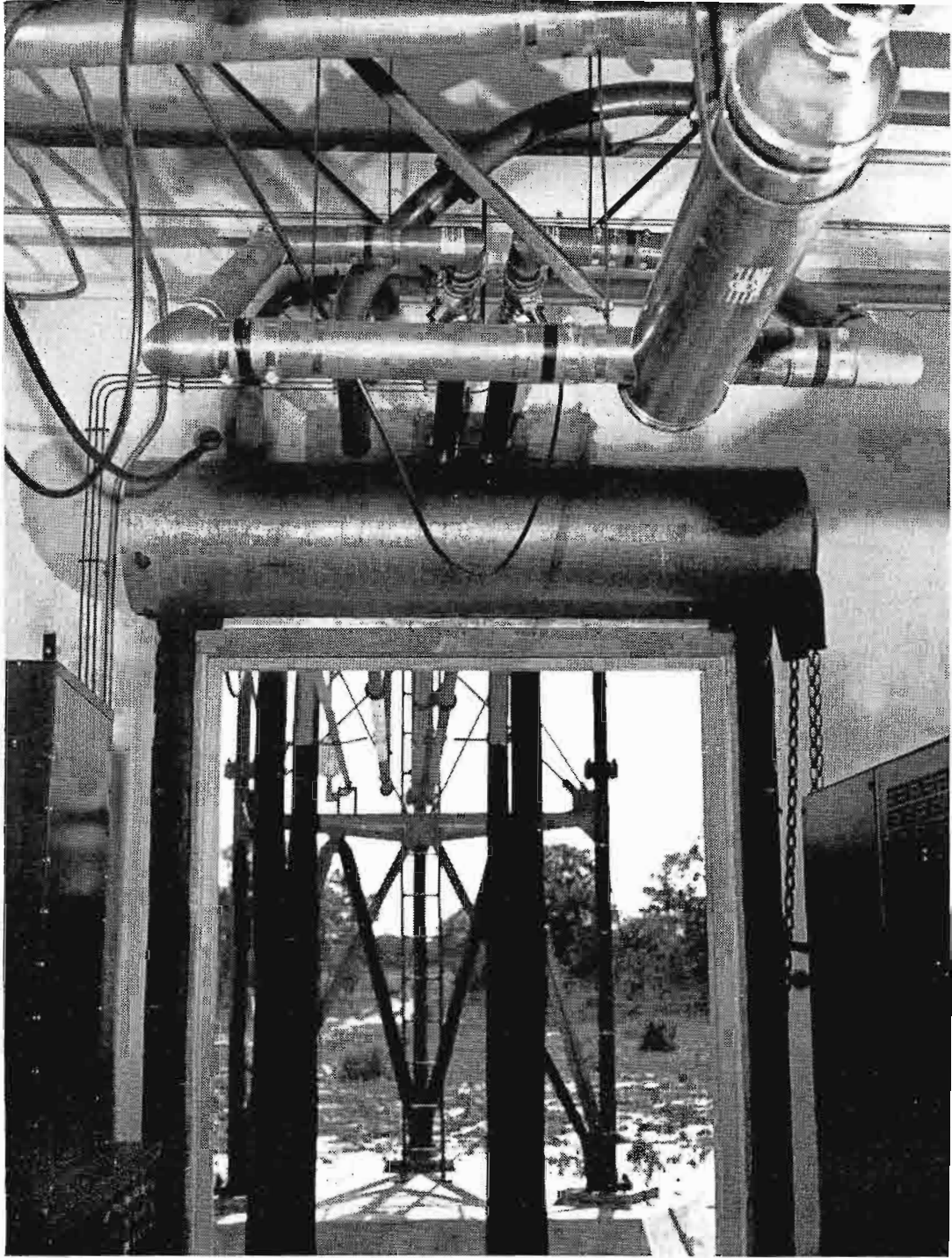

FIG. 28. Transmission line run from diplexer through building wall to building exterior.

FIG. 29. Overhead "plumbing" is side band filter, harmonic filter and diplexer.

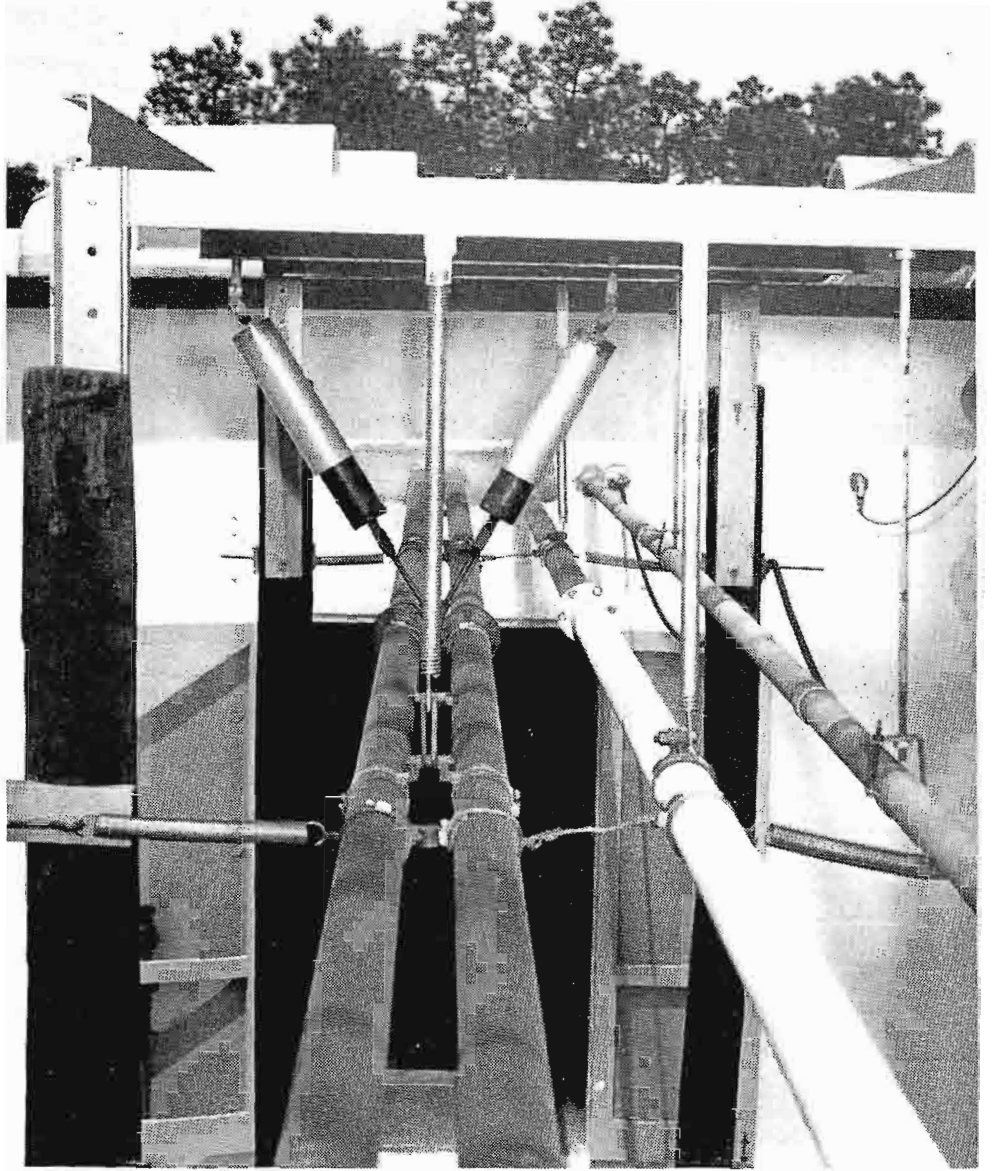
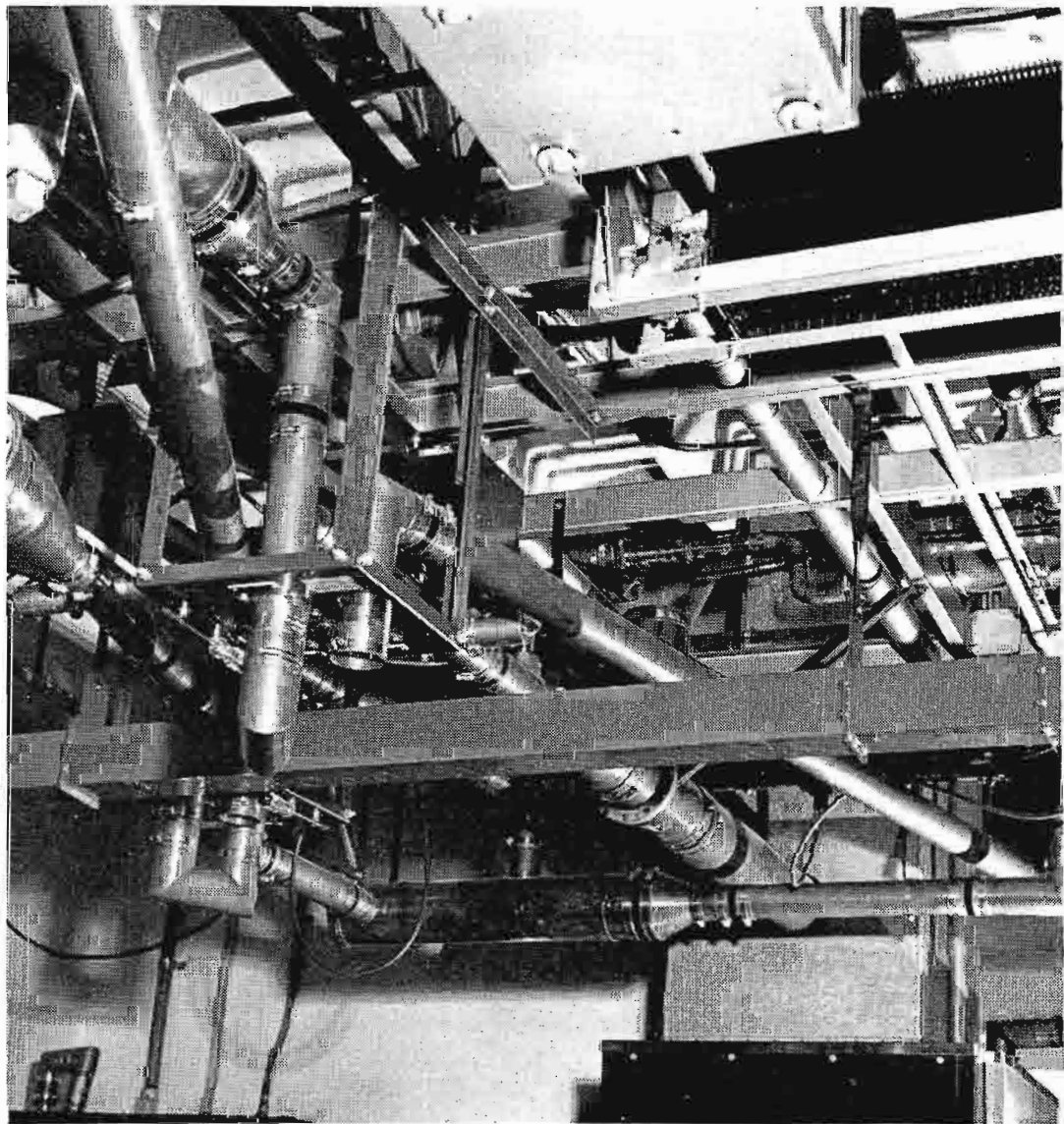

FIG. 30. Transmission line leaving building wall supported by a "do-it-yourself" shock absorber technique. Similar supports are used further along the line near the tower.

and normaled to regular sources. Microphone receptacles in studios "B", "C" and "E" come up to jacks and may be patched into either console.

AM Transmitter

WFLA's AM transmitter is an RCA BTA-5G which was installed in December, 1954, replacing an RCA 5-DX which had been in use for 14 years.

FIG. 31. Emergency 200 kw generator (right) and 10 kw tower lighting generator (left) stand "ready for action" in a Quonset hut.

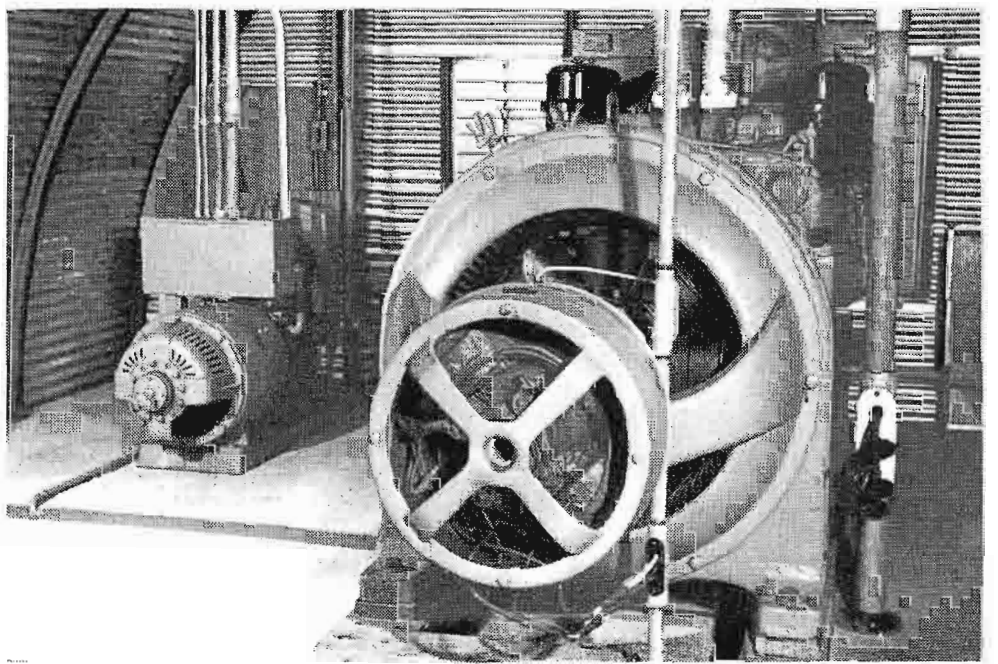

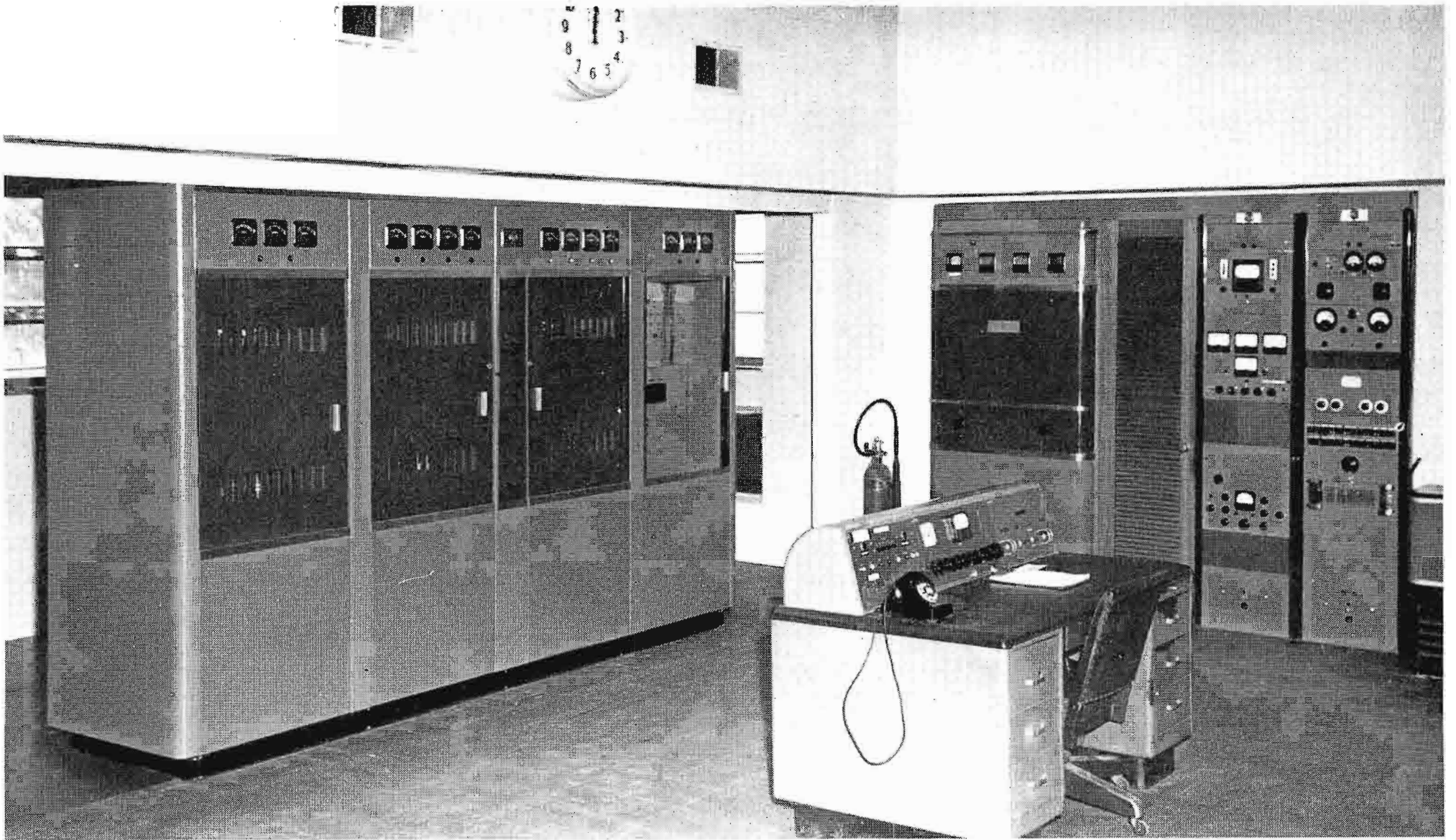

FIG. 32. RCA BTA-5G transmitter installed in same position formerly occupied by the old RCA 5DX transmitter. The space for the 5G is less than half that of the 5DX. The transmitter control console antenna phasing cabinet and rack accessory equipment with the exception of a BA6A limiting amplifier was formerly used with the 5DX transmitter.

The AM site is six miles west of Tampa on the shore of old Tampa Bay, an excellent site for good conductivity and maximum coverage from the three-tower directional antenna system used at night. Daytime operation is non-directional. A 30-kva gasoline generator with automatic switching is provided for emergency power.

Future Plans Center Around Audience Appeal

In less than two years, WFLA has provided the Tampa-St. Petersburg area and the expansive Central Florida Region with the ultimate in television coverage.

WFLA's aggressive activity in remote pick-ups throughout Florida's Wonderlands has won acclaim throughout the nation—especially the many "Wide-Wide-World" sequences viewed by millions.

WFLA plans its future with the finest programming and the most advanced techniques of presentation for its wide audience. Keep *your* eye on WFLA-TV, Channel 8, Tampa.



FIG. 33. View of the front of the AM transmitter building with the three-tower directional array in background. Building was constructed in 1940.

WCAU MODIFIES 3V-SYSTEM FOR LIVE COLOR COMMERCIALS

Fourth Input Added to TP-12 Multiplexer Also Provides Staging Area for Color Opaques, With Studio-Type Panning and Dolly Effects

by FRANCIS J. HANEY,
General Engineer—WCAU, Philadelphia, Pa.

A color opaque adapter, designed and built by our engineering group, allows us to produce color opaques and live commercials of actual products through a fourth input to our 3-V system. The opaque unit, consisting of an extension lens system, a mirror assembly and a staging area, has provided excellent color quality through the 3-V Color Film Chain.

Color film and slide facilities have enabled the broadcaster to add a local touch to his color program schedule. Throughout the years of monochrome telecasting the broadcaster has become accustomed to

working out new ideas either on the spot or as soon as artwork can be prepared—and usually at minimum expense. However, with color film and slide facilities such ideas must first take visible form (as is the case with monochrome) and then a color photograph taken before final evaluation can be made.

This latter step suffers from at least three disadvantages, any one of which can cause the death of a good idea—additional cost of photography; loss of valuable time in color photographic processing; and loss of some color values and qual-

ities. The addition of a “live color and opaque” unit to existing film and slide facilities would thus be of great value.

Inasmuch as the 3-V system comprised our only color originating facilities, the logical choice was to add to this. Consideration was given to the flying spot scanner type opaque unit. However, this would have been a step backward, for the 3-V system was chosen initially because of its advantages over the flying spot system.

Consideration of the optical requirements led us to conclude that the optical

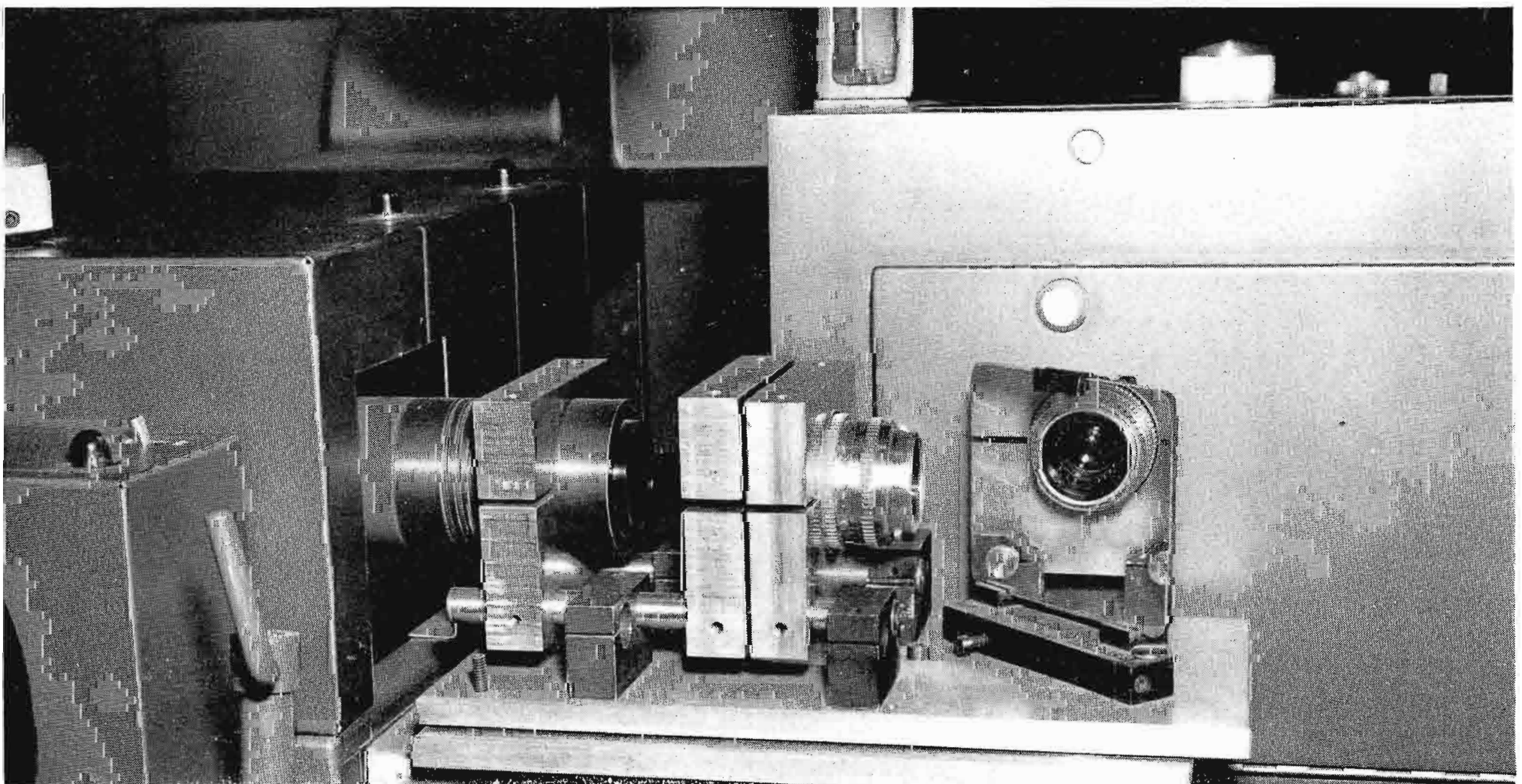

FIG. 1. Extension lens system with cover removed is shown mounted on $\frac{1}{2}$ inch brass bedplate which is supported by an angle-iron frame.

FIG. 2. Color opaque adapter for live commercials which has been added to give WCAU a fourth input to the 3-Vidicon Color Film Chain. Staging area (in foreground) is mounted on an old milling machine. Extension lens system can be seen alongside TP-6 projector.

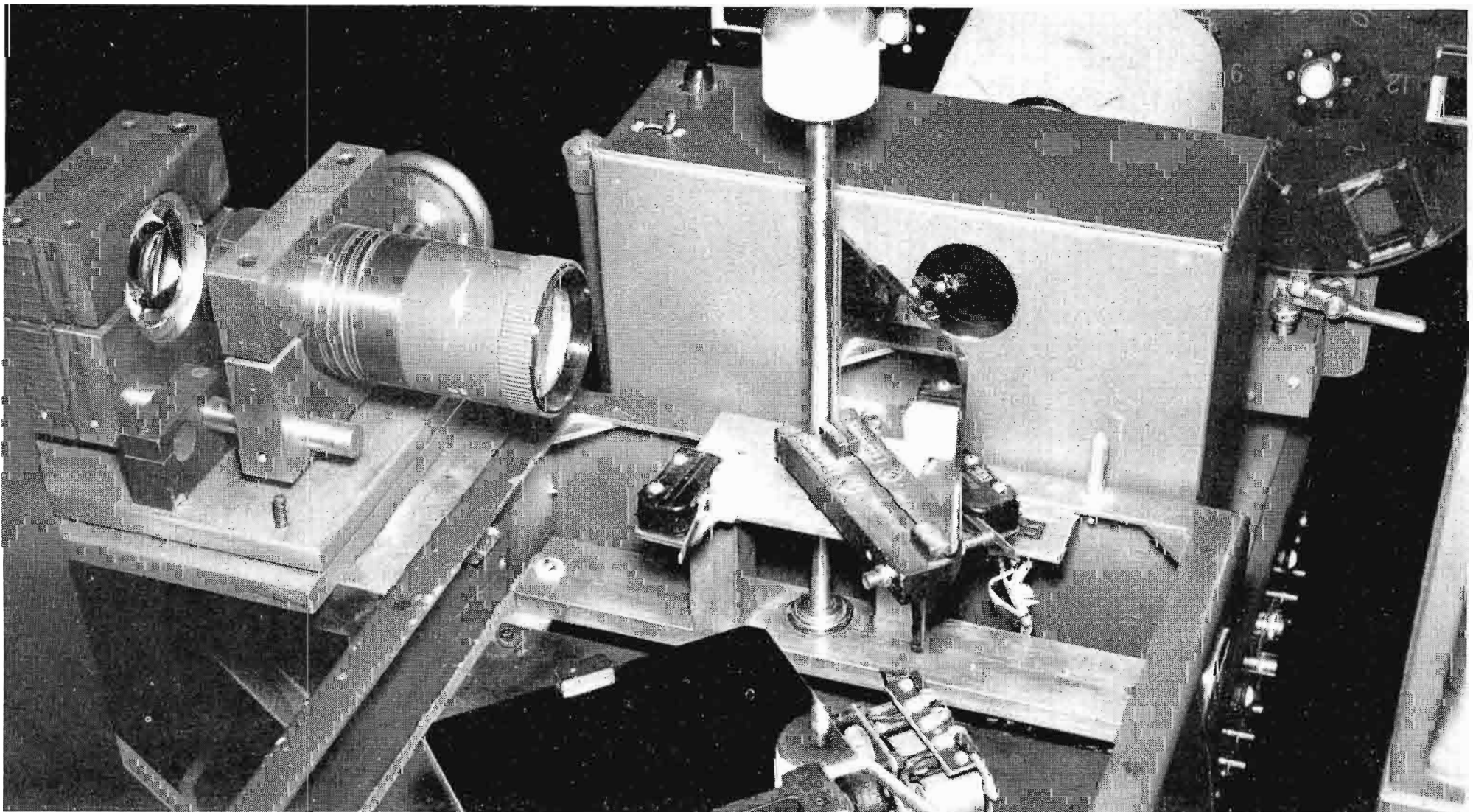
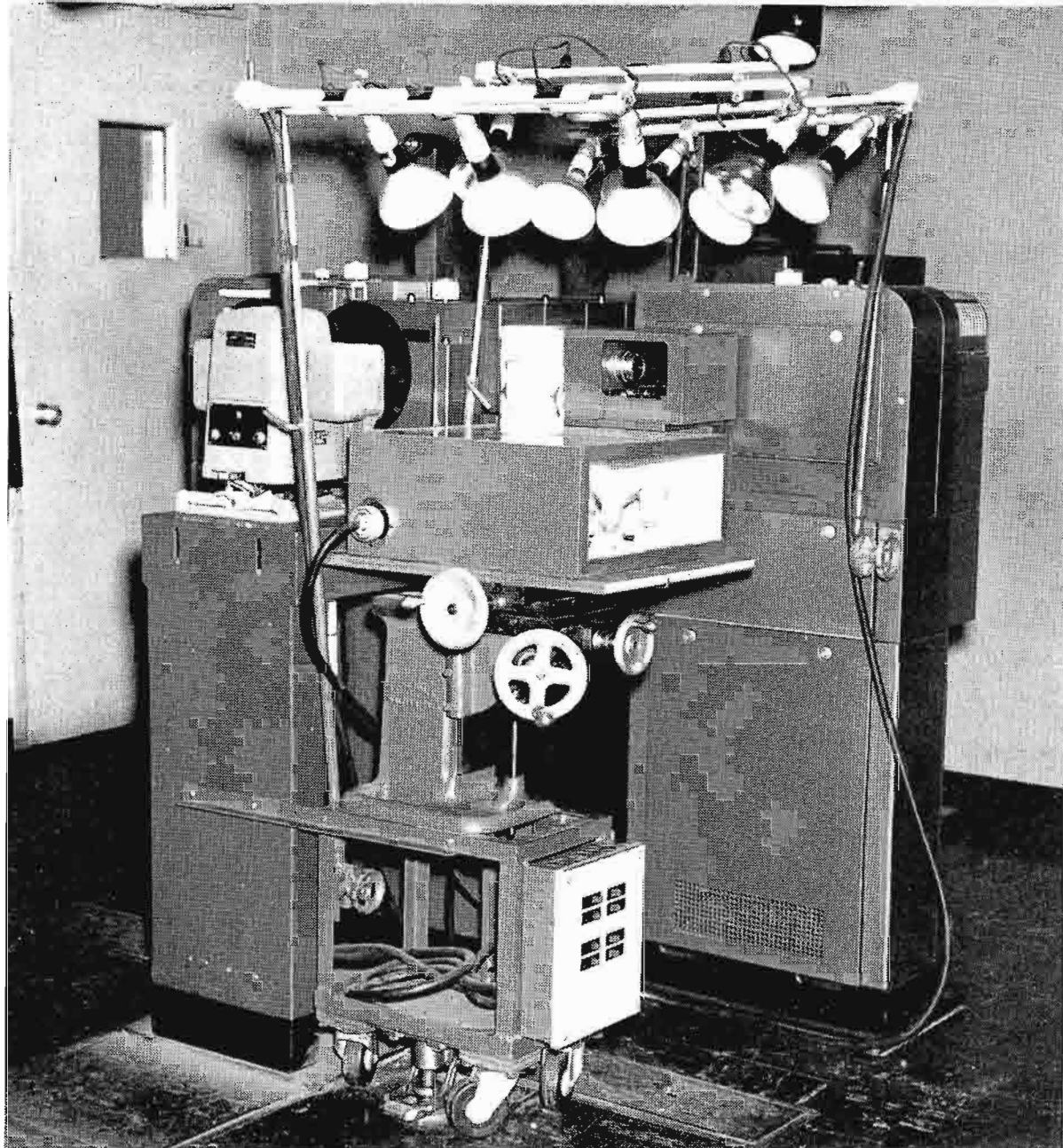

FIG. 3. Cover on TP-12 multiplexer has been removed to show mounting arrangement of manually operated mirror.

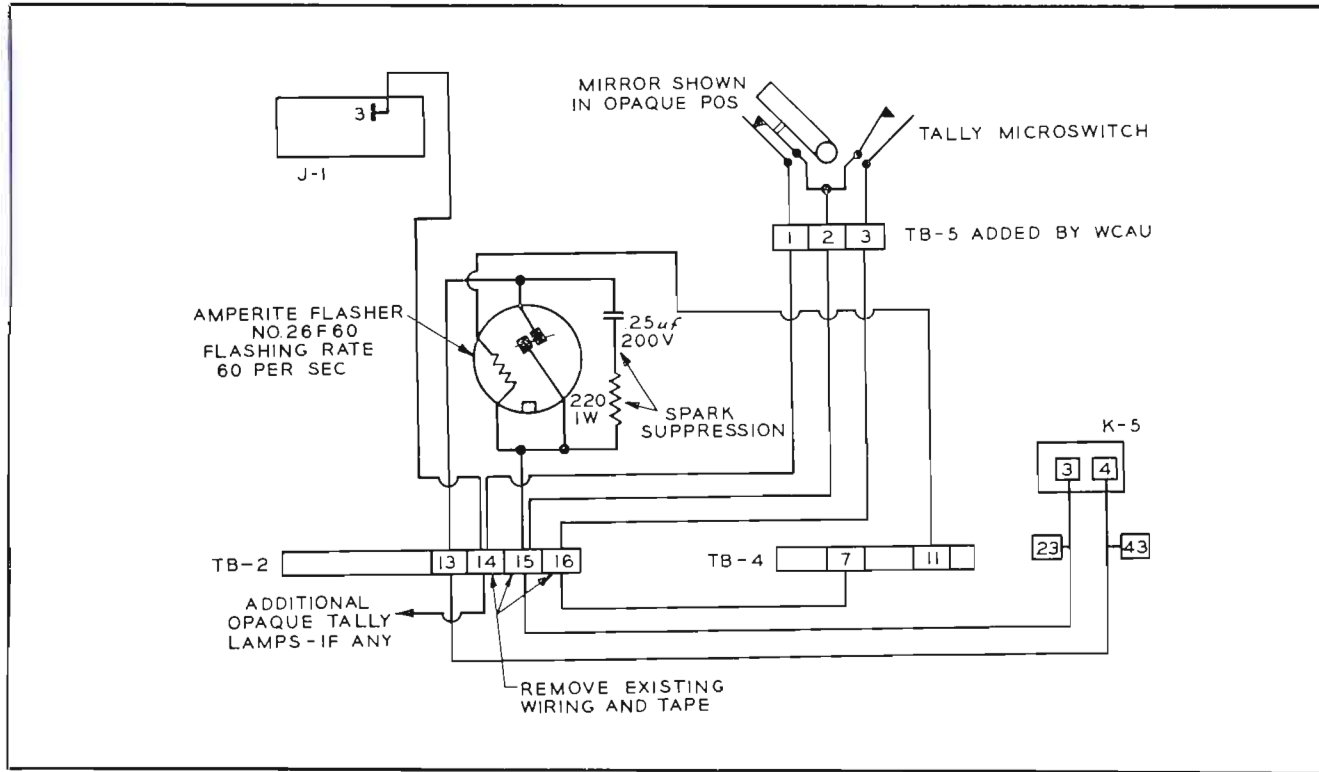

FIG. 4. Tally circuit is used to indicate mirror position for either opaque or slide input. Flashing tally operates when film is in use to indicate mirror position.

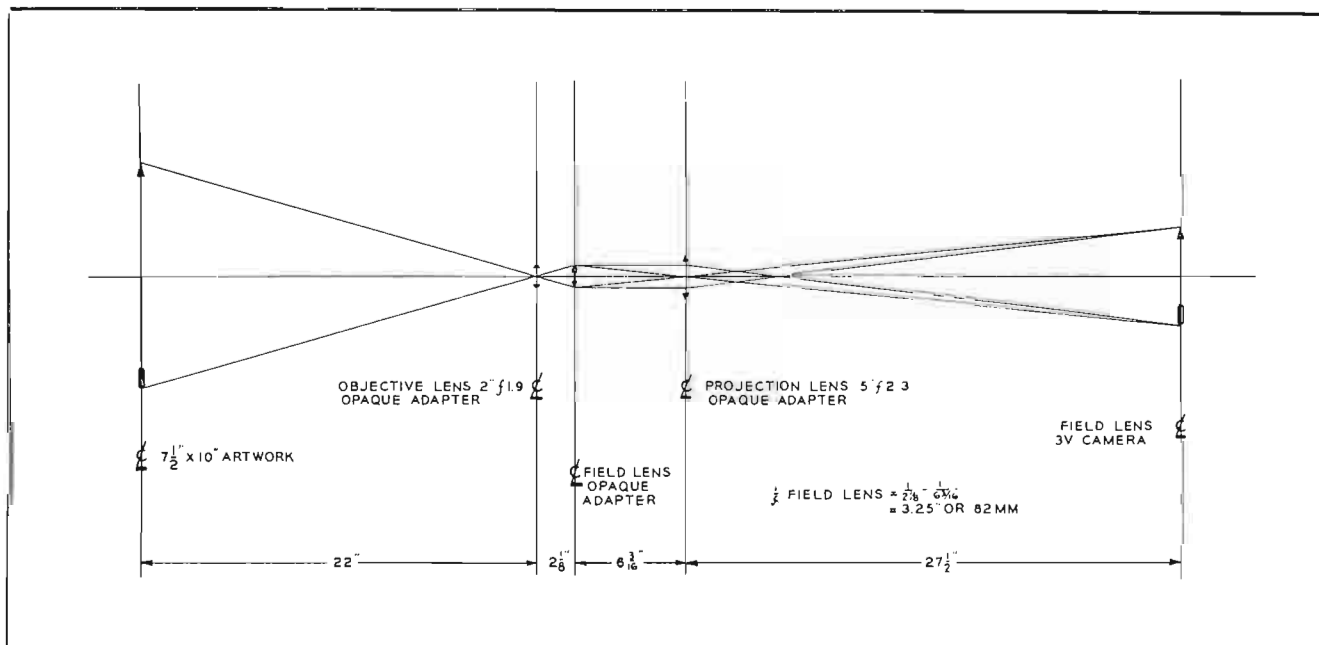

FIG. 5. Optical schematic showing lens arrangement for fourth input to TP-12 multiplexer in 3-V Color Film Chain.

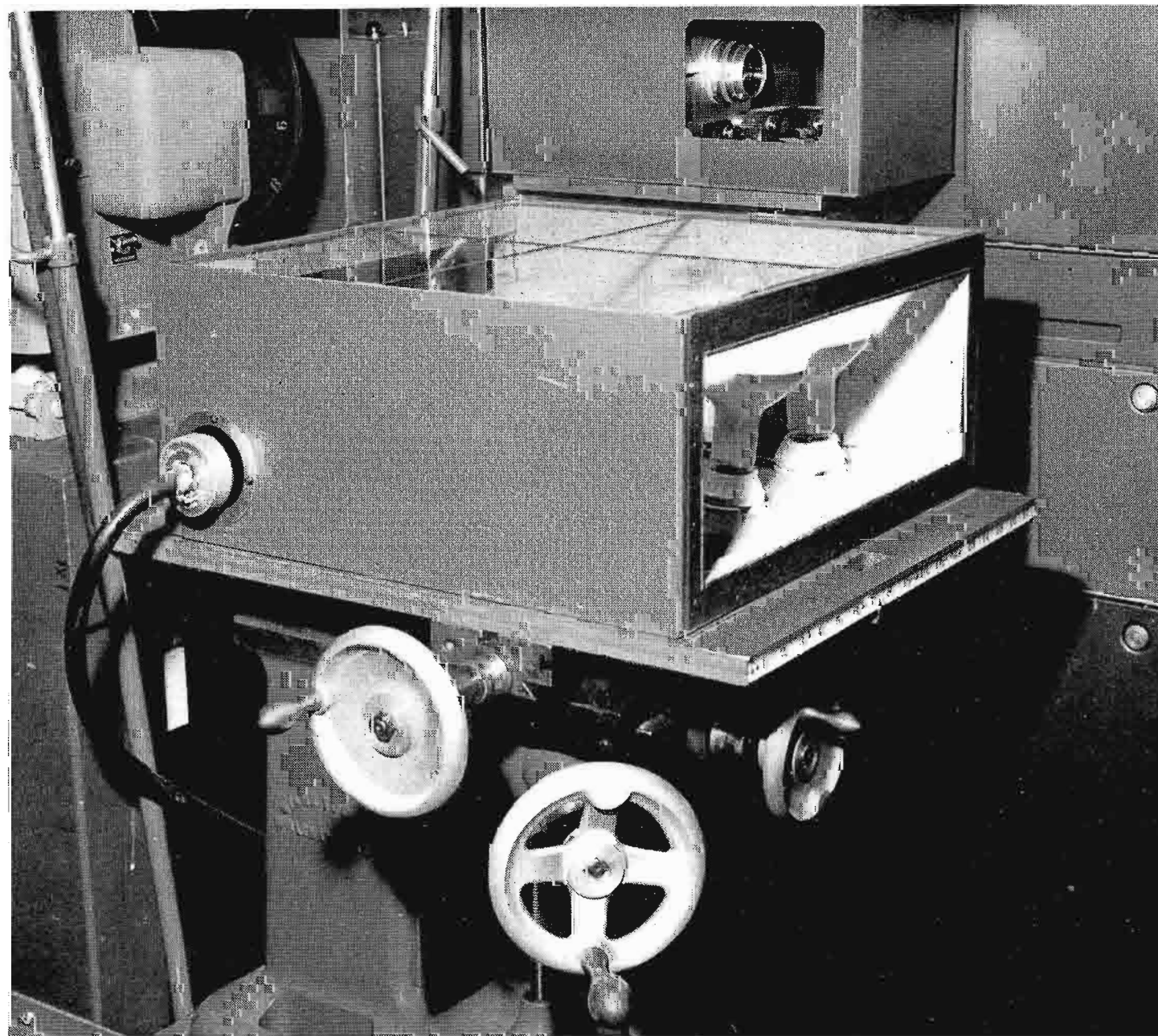

FIG. 6. Illuminated base with nine 500-watt lamps has proven very effective in presenting liquid displays. Milling machine permits lateral and vertical motion. Note the quick indexing device on the edge of the stage foundation—portion of a flexible metal rule fastened to 3/4 inch ply board.

system for this opaque unit should be: very fast; use standard lenses; and be moderate in cost. Such a system was developed by RCA for use with the TP-15 multiplexer. Ours was then to modify these optics for use with the TP-12 (which has a throw distance shorter than the TP-15), modify the TP-12 to handle a fourth input, and design a miniature staging area.

It was believed that a stage area 12 by 12 by 14 inches would handle most of our present and future needs, as well as be consistent with lighting requirements and working space available in the projection room. Base lighting is approximately 10,000 foot candles of incident light. We believe that an attempt to illuminate a larger area would be impractical.

Optics

Figure 5 shows the optical schematic and the field lens focal length computation. Note that the pickup lens is a standard 50mm f1.9 lens, the opaque field lens a simple double convex lens coated for low reflection properties, and the projection lens a standard Ektagon 5 inch f2.3 lens.

Each lens is mounted in a sliding brass block to facilitate alignment and replacement in the event of future changes. The brass blocks slide on hardened steel rails made of drill rod. This sliding assembly together with reversal mirror is secured to a $\frac{1}{2}$ inch brass bedplate. Brass was selected solely because of its ease in machining. This bedplate is fitted with three levelling screws. An angle-iron frame secures the entire optical assembly to the side of the TP-12. A 16-gage cover protects the lenses and helps to keep out dust and stray light. The angle-iron frame is equipped with a Stanley hinge to permit access to the TP-6 16mm projector.

Mirror Assembly

A moving mirror situated at the intersection of the 3-V and opaque unit optical axes serves to complete the fourth input. The method of operation of this mirror was given considerable thought. It was originally hoped that a motor-driven mirror, similar to the two existing in the TP-12, could be added. Unfortunately lack of space prohibited the use of this or any other commercially available units. The choice was then to construct either a manually operated or a motor/solenoid moving mirror. A fixed half-silvered mirror was dismissed on the basis of resulting loss of much needed light.

A manually-operated mirror was finally selected because time was somewhat of a

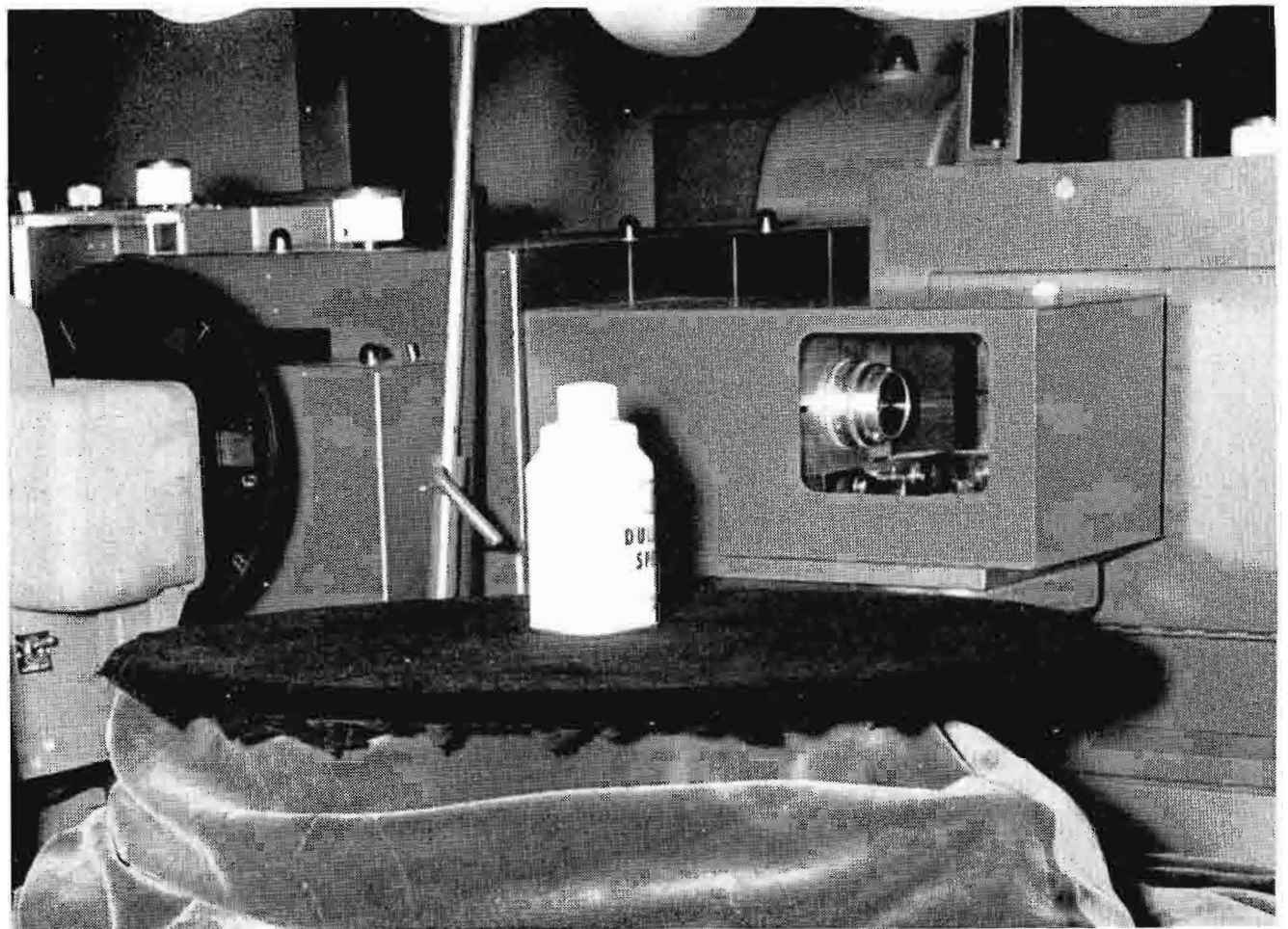

FIG. 7. Revolving turntable attachment is used to display products in motion.

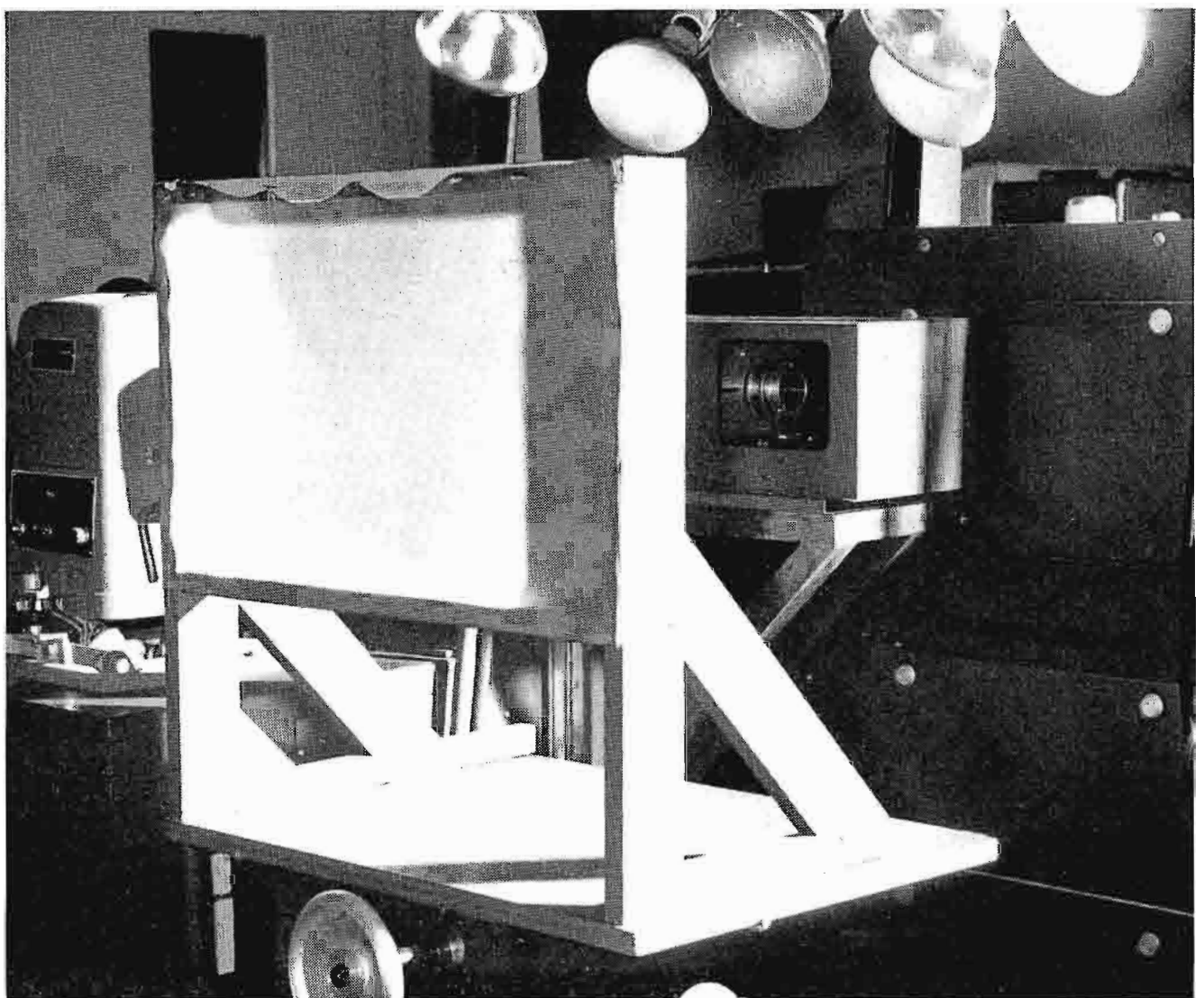

FIG. 8. Stand with translucent screen makes rear-screen projector available for fourth input to TP-12 multiplexer.

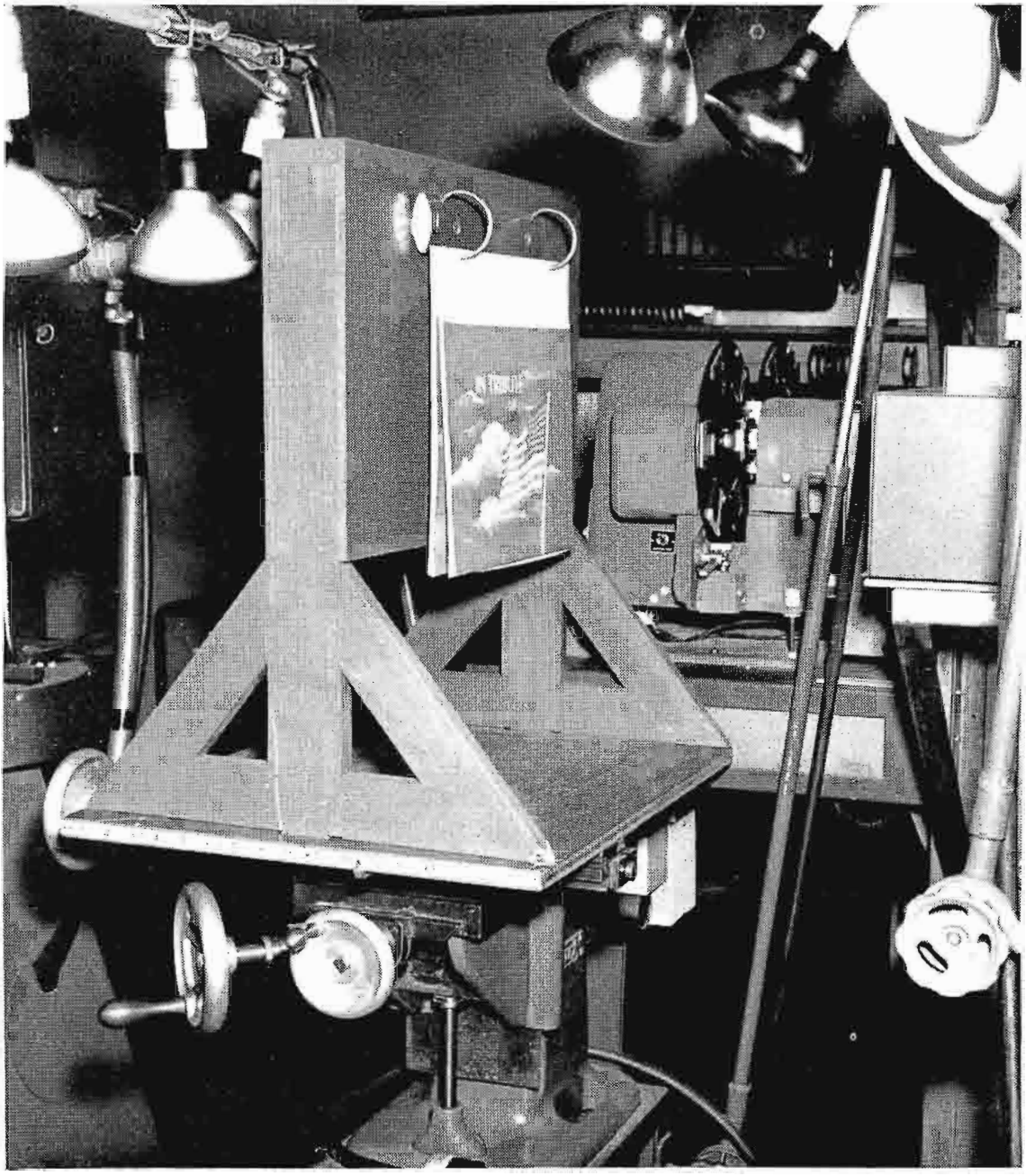
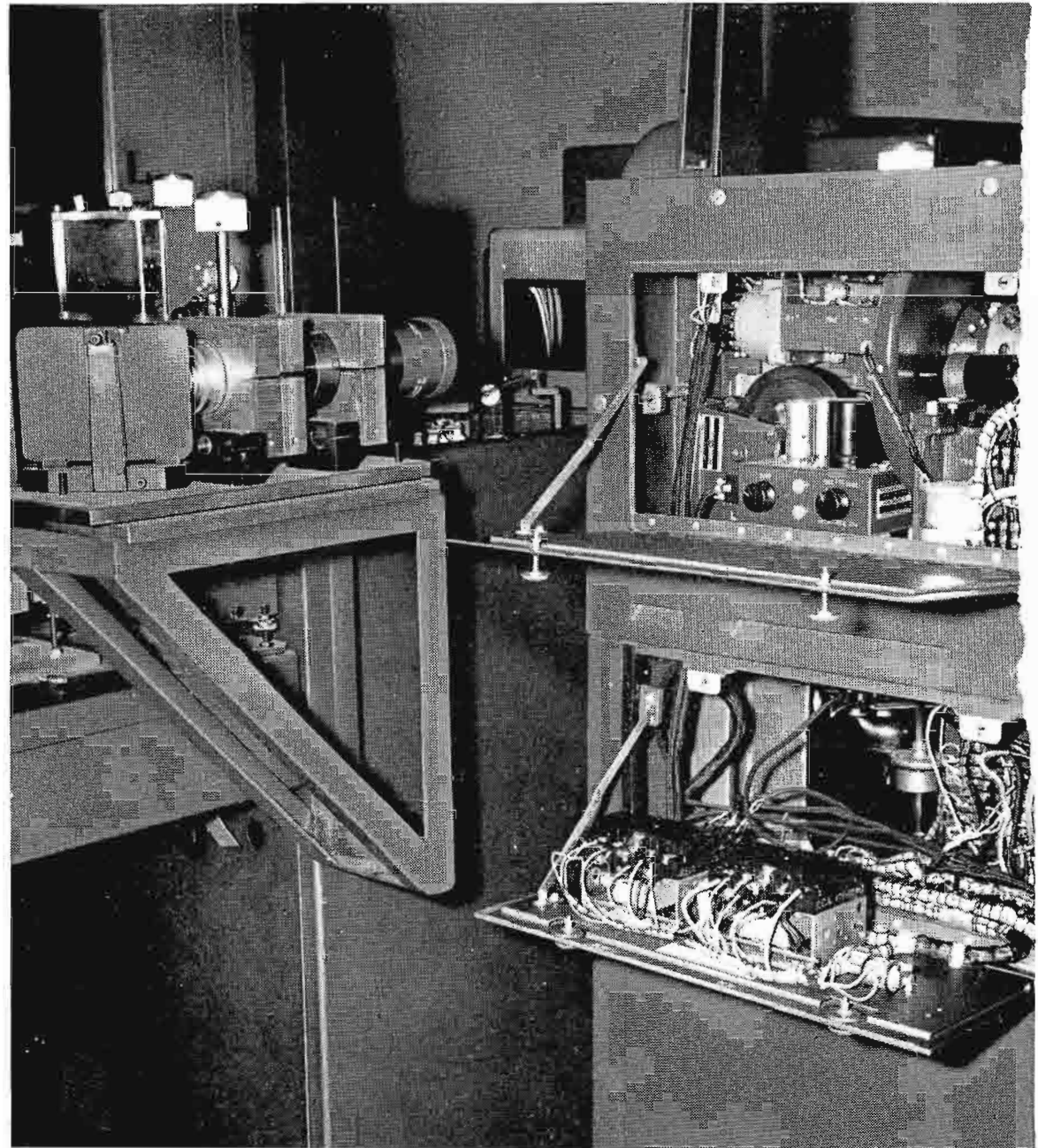
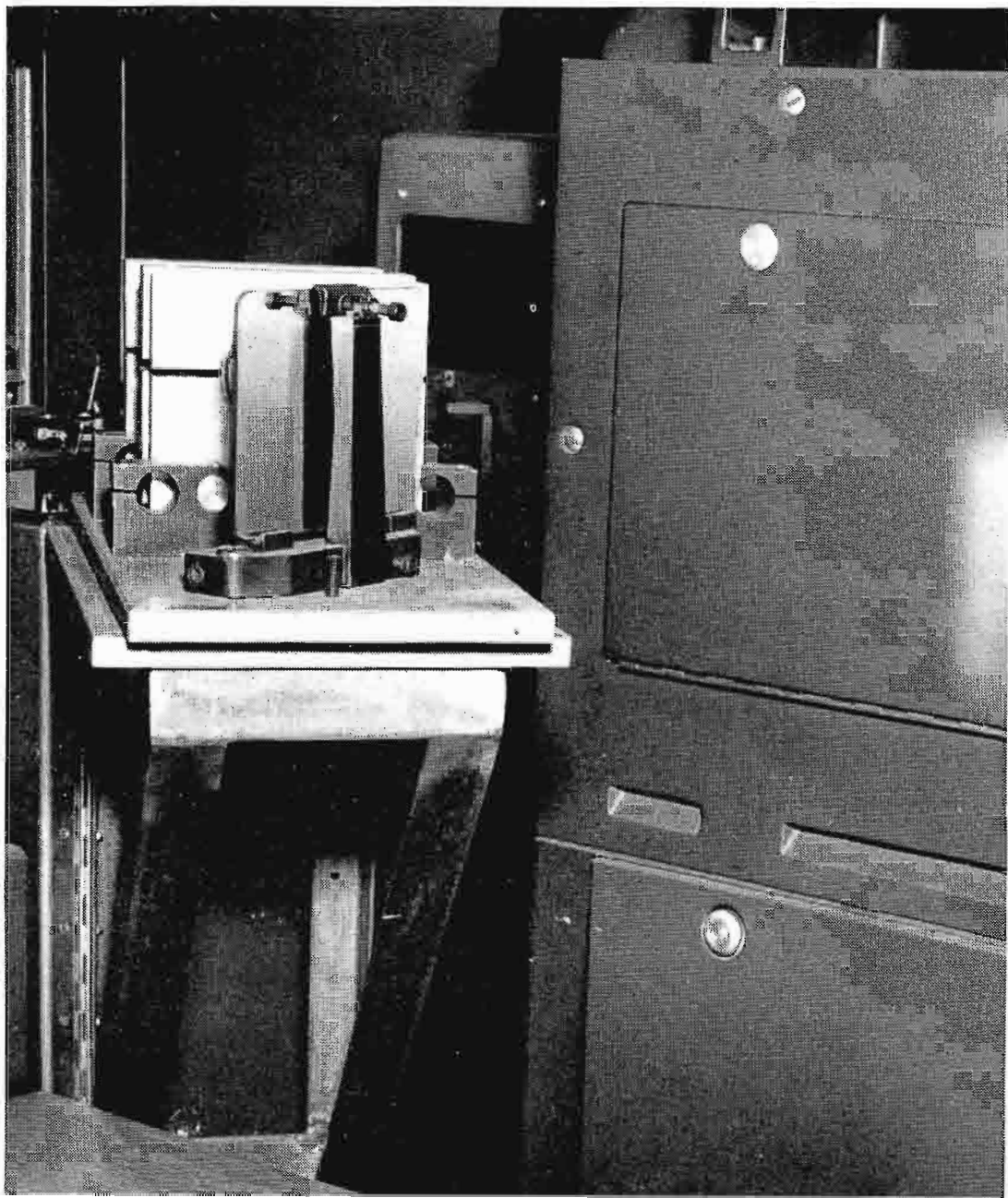

FIG. 9. Color opaque adapter attachment consists of easel stand for title cards, artwork, etc.

FIG. 10. Angle-iron frame supporting the optical assembly is equipped with a Stanley hinge. This allows access to the TP-6 16-mm projector for maintenance purposes.

FIG. 11. Optical assembly of extension lens system can be rotated 90 degrees when staging area and milling machine are moved out of the way.



factor and this unit would require less design and construction time. In addition, an operator would be on duty at the 3-V position to handle film, slides and lighting, who could easily operate the mirror if it should be necessary.

The mirror mounting is attached to a vertical shaft of $\frac{1}{2}$ -inch drill rod. The shaft is supported by two permanently sealed ball bearings. These bearings are surprisingly low in cost, will handle both radial and thrust loading, and require a minimum of auxiliary machining work. The bearings are "press-fit" both onto the shaft and into the bearing support plates. Once again brass was used to facilitate machining. An off-center spring arrangement is used to supply most of the motive power and to keep the mirror in its stop. Nylon bumper blocks are used as shock absorbing stops.

A tally circuit was added to show the position of the mirror when either the slide input or the opaque input is in use. Two micro-switches actuated by the mirror are used to operate the tally lights. By means of a memory circuit, a flashing tally light indicates the position of the mirror when film is in use.

Staging and Lighting

Having completed the optical portion of the opaque attachment to the 3-V system, our next step was to design an illuminated staging area that would yield as many of the advantages of a studio type camera operation as practicable. Essentially, this means ease and versatility in lighting coupled with dolly and panning facilities.

Obviously the 3-V chain could not be made to move easily, so that any motion would have to occur on the stage area. A used milling machine was located which suited the purpose ideally, since it gives smooth motion in all three dimensions. With the optical unit yielding an approximate depth of field from 8 to 12 inches, some on-the-air motion can be used.

A $\frac{3}{4}$ -inch plyboard is fastened to the top ways of the milling machine and serves as the stage foundation. On this foundation the following attachments can be placed:

- An illuminated display base (very effective for liquid displays),
- Either a translucent (for rear screen projection) or opaque backdrop,
- An easel stand for title cards, artwork, etc., and
- A revolving turntable for displaying products in motion.

Dimensions are such that the backdrop or easel can be used in combination with either the display base or turntable.

FIG. 12. The milling machine, stage foundation and lighting booms shown here can be quickly removed from the 3-V Color Film Chain should this prove necessary for maintenance purposes. Note the lighting switch panel (lower left) used for power distribution to the light booms, the light box, the revolving turntable and two accessory outlets.

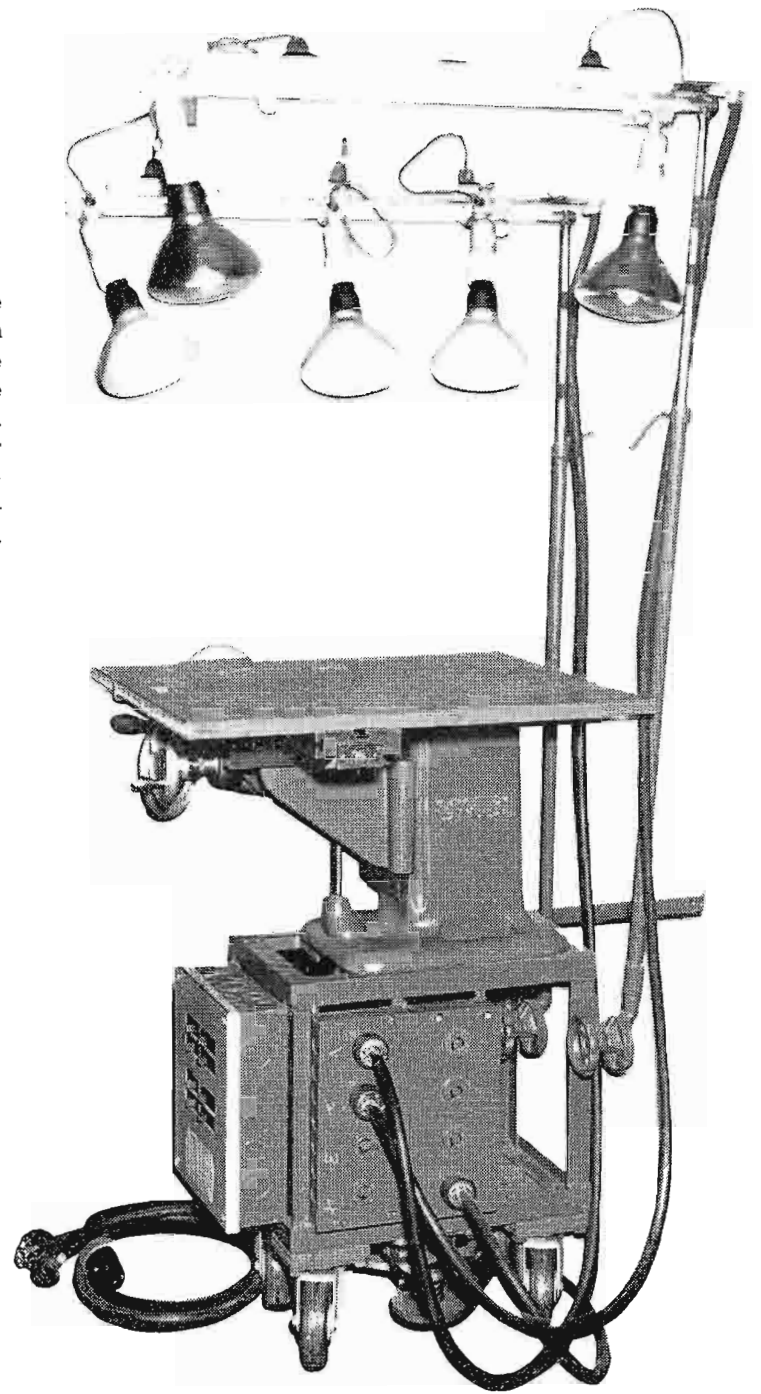

Mounted on the base of the milling machine is a lighting switch panel. This serves to distribute power to the three adjustable lighting booms, the light box, the turntable and two accessory outlets. The lighting booms were constructed from discarded music stands and are adjustable both in elevation and angular position. Plugmould outlets are fastened to the boom, providing ac facilities along the length of the boom. Clamp-on adjustable sockets serve as the spot and flood light holders.

Operation

The 3-V chain operates normally in every way with the inclusion of the opaque adapter unit. The chain is pre-air adjusted in normal fashion by use of the registration slide. Next the opaque is punched up and white balance checked. Usually it will fall within the range obtained between the film and slide projectors but if not, a slight compromise can be made. By the use of 500 watt RSP-2 and RFL-2 lamps sufficient illumination and excellent color temperature match can be obtained.

An incident reading light meter may be used at first until familiarity with lighting requirements is obtained. The final light-

ing will be determined by picture quality, along with sufficient video level. Our normal practice has been to keep the pickup lens wide open at f1.9 and adjust lighting by the number and positioning of the lamps. These lamps give off a considerable amount of heat and usually as few as possible are used.

Conclusion

The opaque adapter has in every aspect exceeded our fondest expectations. Color quality is excellent and, it seems to us, equal to that obtained from live image orthicon cameras. Underneath lighting obtained from the illuminated display base is very effective for our commercial beverage displays. The turntable adds the element of motion to certain types of displays. The easel is utilized to show original artwork as it comes off the sketch pad. Even rear screen projection has been moderately successful.

The opaque adapter will, in addition to giving the broadcaster the many advantages of a fourth input to his 3-V system, yield much valuable experience in live color handling that will benefit him when he adds the inevitable and ultimate live color studio cameras.

RAI

RADIO TELEVISIONE ITALIANA



by PAUL A. GREENMEYER,
Managing Editor, BROADCAST NEWS

FIG. 1. Typical American type of quiz show has put a shot in the arm of the Italian TV industry. Called *Lascia O Raddoppia* (Leave or Double), the show has a jackpot of 5 million lire (\$8000).

(United Press Photo)



Television has in it the seeds for sprouting a booming industry in Italy despite several assorted handicaps. Programming is becoming sufficiently attractive—especially through the introduction of a jack pot quiz show—to spark buying of sets and receiver licenses. Geographical coverage of the Italian peninsula is proceeding according to an excellently conceived plan as RAI engineers struggle under the difficulty of having six or seven different kinds of equipment to contend with.

Radio Televisione Italiana is the organization that operates this TV network, as well as a comprehensive network of radio stations. Since the radio net has been in operation for more than twenty years, it blankets the peninsula with its three program channels but the TV system, being a more recent development, offers only a single program.

The TV system operates out of three large centers of population—Rome, Turin and Milan. In the studios at Milan we observed operation of the RAI, and inspected their largest TV transmitter installation—an RCA Type TT-10AL 10 kw unit—atop nearby Monte Penice. At Brunate near the Italian-Swiss border, we paid a visit to a typical automatic repeater station, many of which are scattered about in the more remote places of Italy to provide TV fare for local consumption.



FIG. 2. The RAI television system has 36 stations in operation. By the end of 1957, there will be a total of 77 stations covering all of Italy.

RAI is owned by IRI (Istituto Ricostruzione Industriale) which also owns other industries and farms in Italy. This organization consists of a group of banks formed under government supervision during the depression of 1936, in order to save failing farms. It is controlled by the government, with 51 per cent of the capital being supplied by the state. As a result broadcasting is, in effect, a state monopoly.

Television is now noncommercial in Italy, station income being received from fees paid by viewers, however a movement is afoot to switch to commercial operation. Although radio is semicommercial, a nominal fee of 3000 lire (\$4.80) is charged for a yearly receiver license. The TV fee of 15,000 lire (\$24.00) yearly includes radio also. For this sum one receives 10 hours of radio plus 5 to 6 hours of TV daily.

Nationwide Network

The RAI TV system consists of a network of stations divided into three classes: primary stations, secondary stations and automatic repeater stations. Primary stations are higher power than secondary; and both are linked together by means of a microwave relay system. Automatic repeater stations (which are what those of us in the U.S.A. term translators) pick the TV signal off the air and rebroadcast it on a different channel for local con-

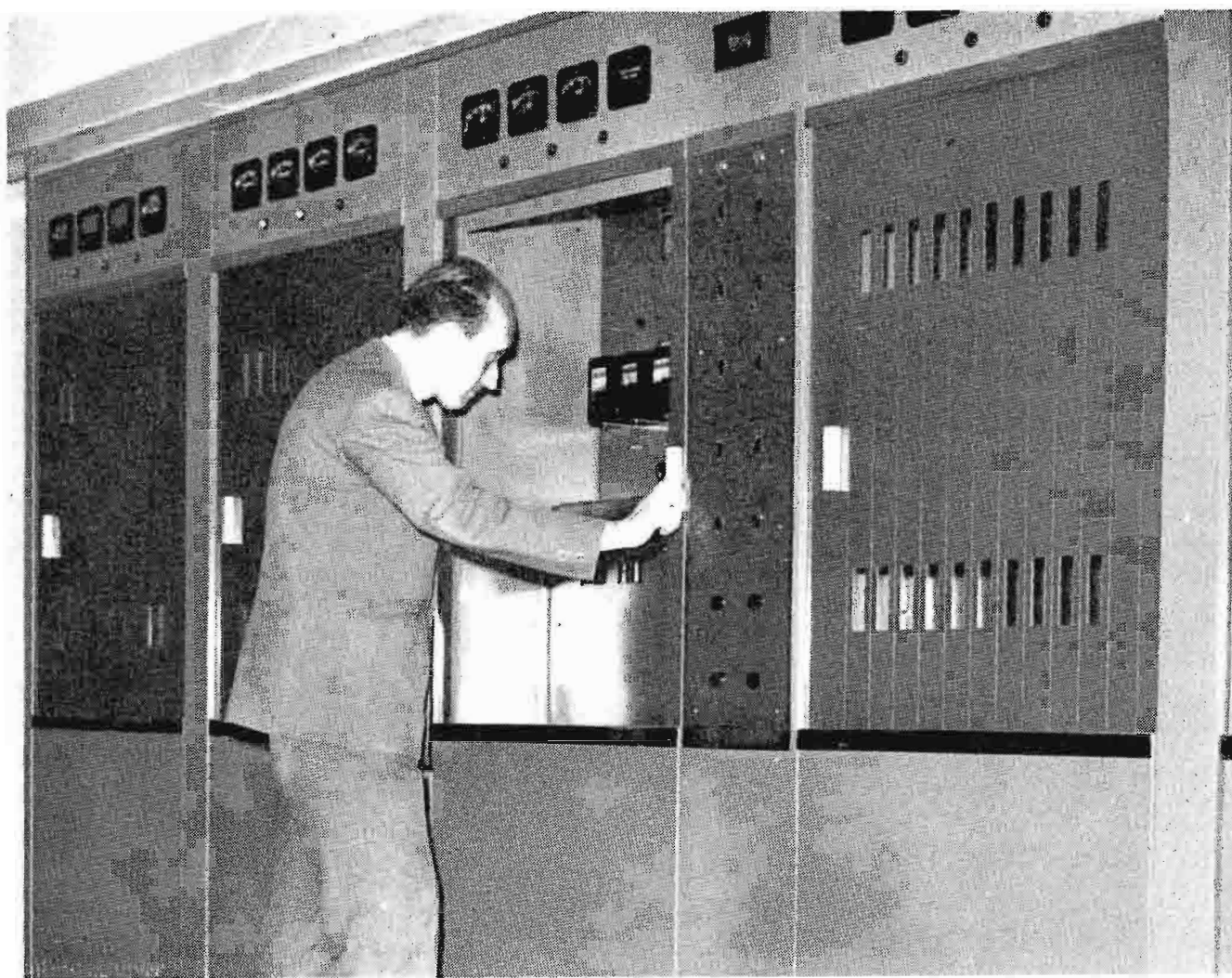

FIG. 3. RAI Transmitter Engineer Alexandro Galeazzi at RCA Type TT-10AL transmitter. This 10-kw unit is the largest in the RAI system and is, "the best transmitter and the most reliable in all of Italy!"

sumption. Since there is only one program all stations are broadcasting the same program.

RAI began experimental TV operations in Turin during 1949, when several telecasts were made weekly. Operations on a daily basis began at Milan in April 1952 and at Rome in December of the same year. Studios are located in these three cities and the program origination shifts

from one to another during the program day.

It is planned to cover all of Italy and Sicily by 1957 with a total of 77 stations. With its present total of 36 stations RAI is about at the halfway mark. Also in the construction stage is a large TV studio and production center in Rome which will be the eventual headquarters and main program origination point for the entire system.

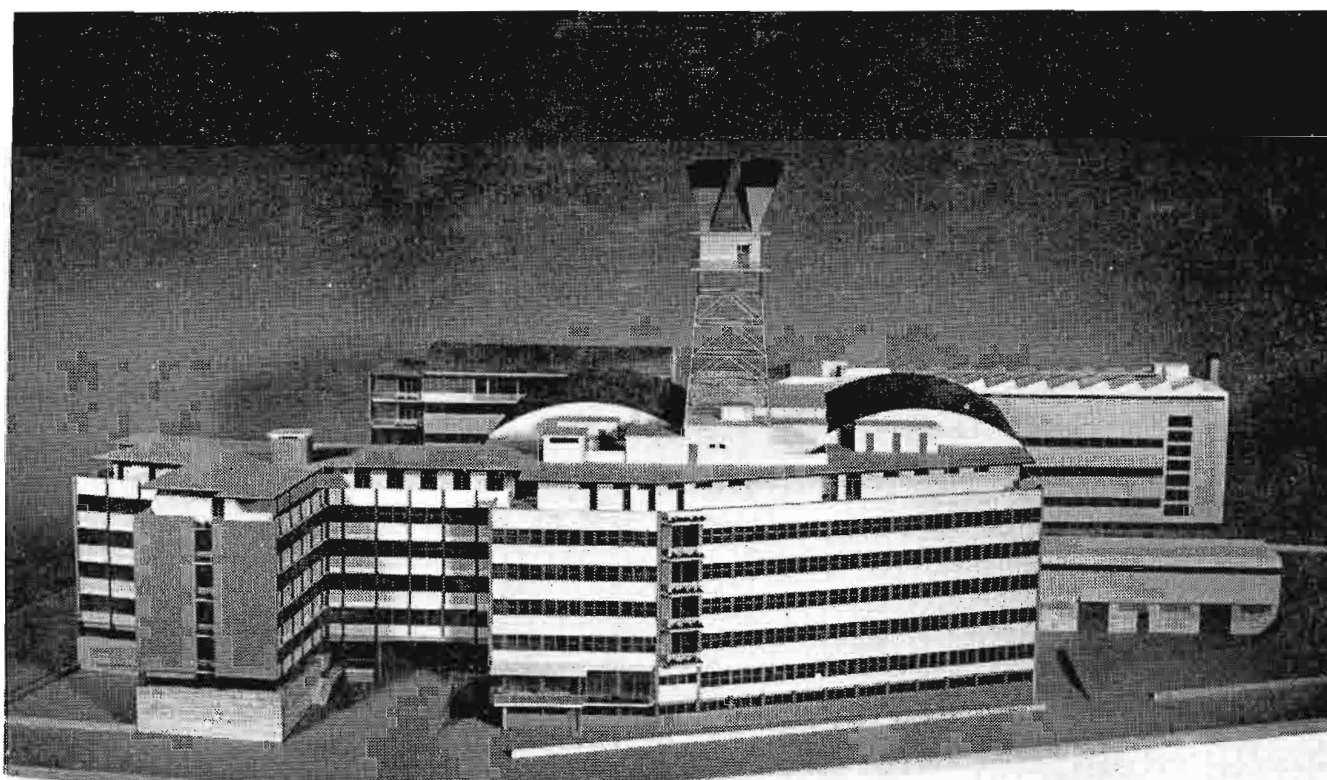

FIG. 4. RAI studios are now located in Rome, Milan and Turin. In the construction stage at Rome is this large TV studio and production center.



FIG. 5. Chief Technical Director of RAI in Milan is Ing. Andrea Magelli.

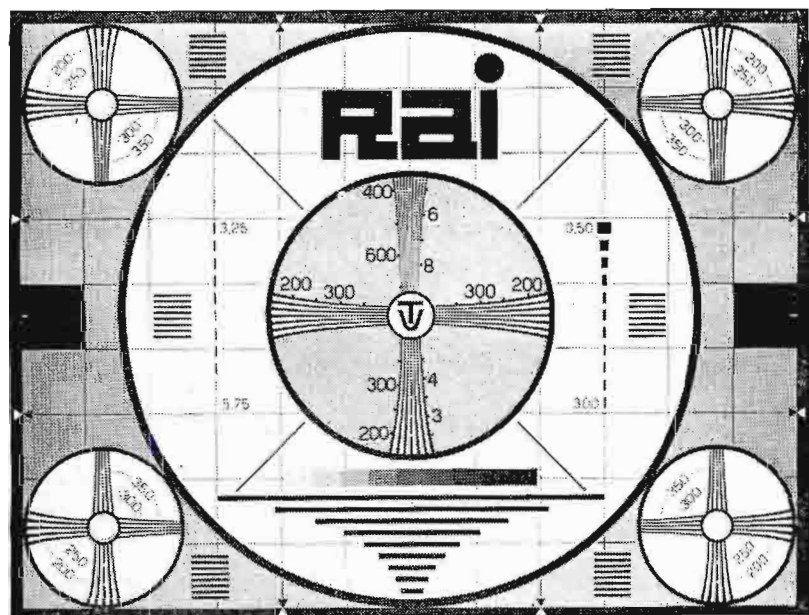
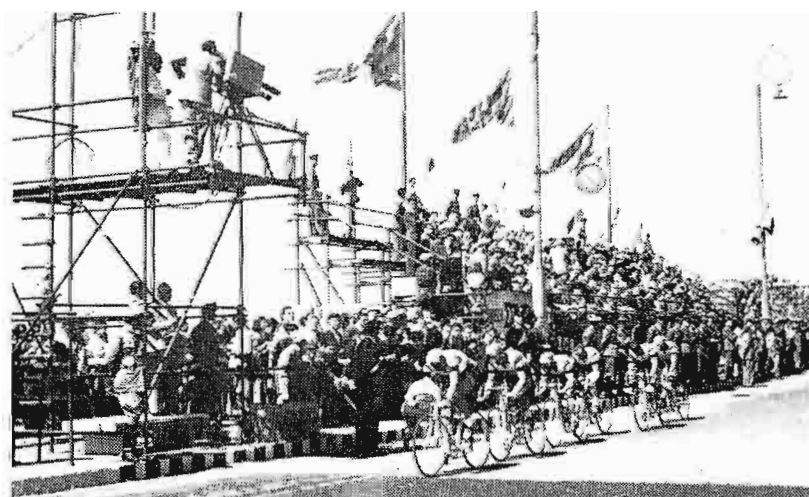

FIG. 6. Test pattern designed by RAI engineers for checking linearity and deflection.



FIG. 7. For the Eurovision network RAI covered the 1956 Olympic games at Cortina, Italy.

FIG. 8. The perennial bicycle races provide favorite sports programs for Italian viewers.



Programming

Operas, a weekly quiz show, sports, and events of national and international importance form the backbone of programming. For example, RAI covered the Olympic winter games in January, 1956 at Cortina, Italy, and RAI mobile units go far afield to cover these games, also special events in Venice, and Italian sports such as the ever-popular bicycle races that have become historic annual events.

RAI has been telecasting operas regularly for two years. This is following the pattern set in radio where it has been done for some twenty years. In TV there is now a regular schedule of one opera every two weeks. The opera program is usually rather long—running from two to two-and-a-half hours. Occasionally there is a short one such as *Cavalleria Rusticana* which we watched on July 11, 1956 from 9:15 to 10:30 p.m.

TV programming runs from approximately 5 to 7 p.m. and 9 p.m. to midnight for a total of 5 to 6 hours daily. On Saturday and Sunday a few more hours in morning or afternoon are programmed. On Sunday, for example, the Mass is telecast directly from a church in either Milan or Turin. On Saturday afternoon a sporting event is often put on air from 12 to 2 p.m. and a film may be run from 4 to 6 p.m.

A rather famous weekly program, entitled *Lascia o Raddoppia* (Leave or Double) is widely credited with putting a

shot in the arm of the TV industry. Lagging set sales began booming as a result of this Italian version of a typical American quiz show with a big jack pot. Participants can win up to five million lire (\$8000). The program began December, 1954 and has been put on each Thursday evening at 9 p.m. ever since. Frequently it generates enough human drama to become national news.

A typical teaching program for all ages is "Passaporto" by Jole Giannini. The English language is taught in this 15-minute program presented twice weekly. Two English-speaking youngsters act as typical students. A handbook (syllabus) has been written by Miss Giannini for her viewing students, who also undertake homework assignments.

Programming originates in Milan, Turin and Rome. Most of the programs originate in Milan—about 70 per cent of them. Ten per cent originate in Turin and the remaining 20 per cent in Rome. With the completion of the new Rome studios, however, it is to be expected that a great deal more programming will originate there.

Audience programs are limited to one studio in Milan—the so-called TV theatre. The weekly quiz show (*Lascia o Raddoppia*) plus two musical programs per week are the only ones that have audiences. Persons wishing to attend write in, then names are drawn from a ballot box. However, many seats are reserved for VIPs.

FIG. 10. Travel Program "The World is Small" captures the fancy of youngsters interested in the adventures of famous explorers like Columbus and Magellan.

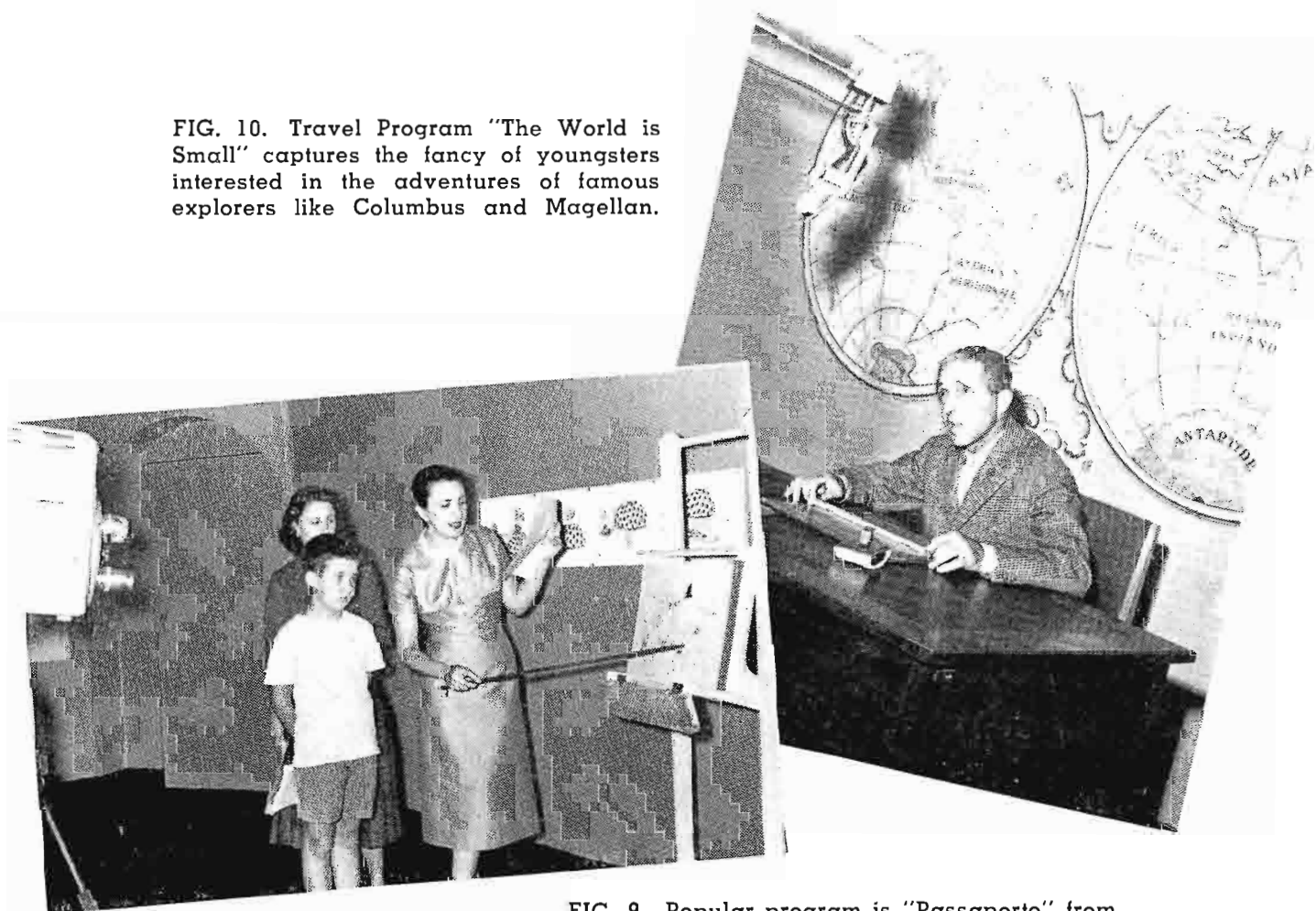

FIG. 9. Popular program is "Passaporto" from Milan, in which Jole Giannini teaches English.

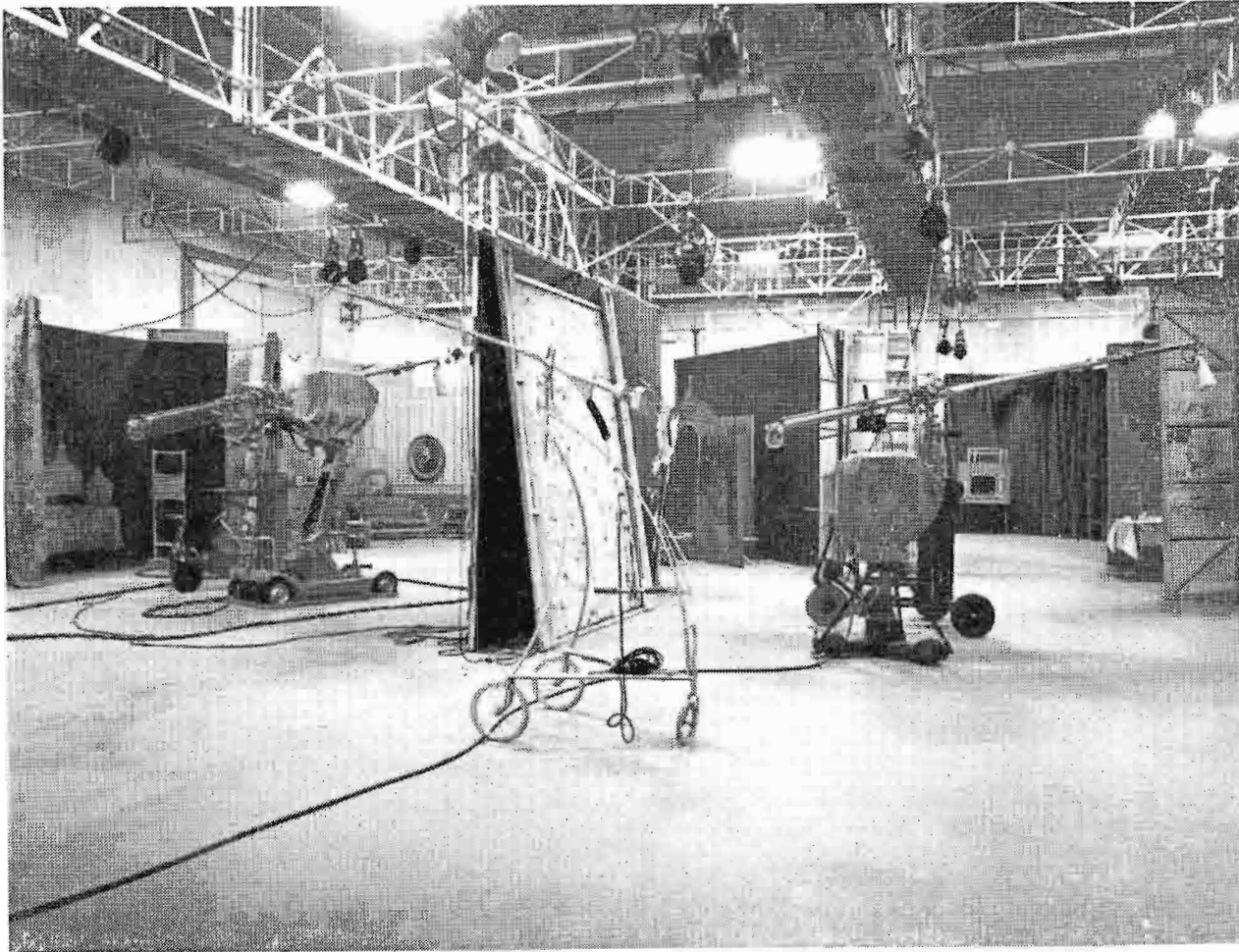

FIG. 11. RAI Studio 3 in Milan is largest in Europe. It is here the biweekly operas are produced.

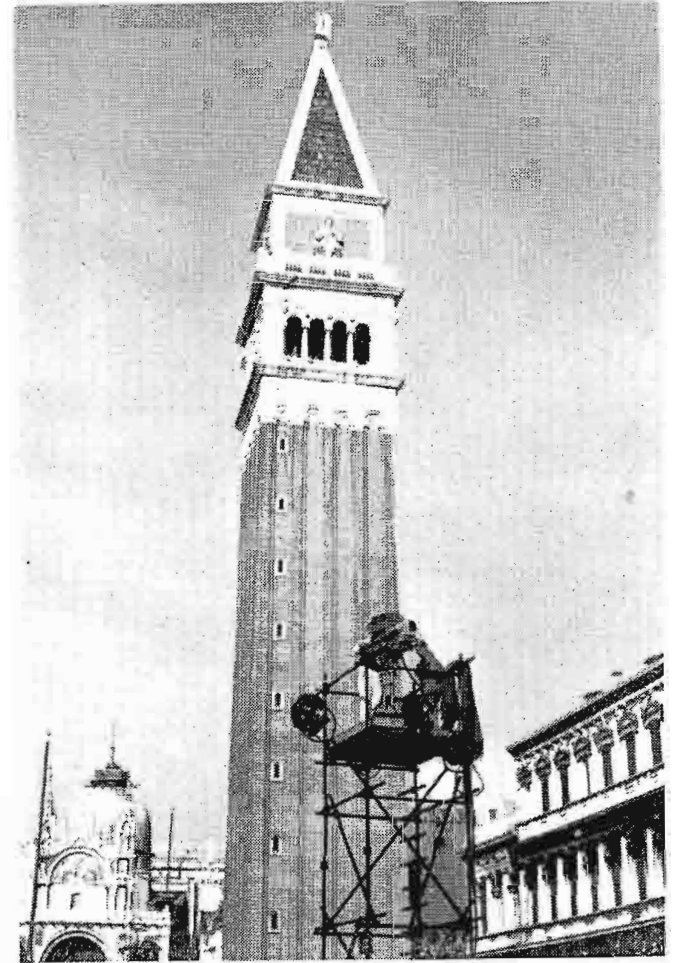

FIG. 12. RAI in Venice. Note St. Marko Cathedral and Tower.

Television Studios

In the three centers used for producing programs, there are at the present time a total of nine TV studios. In Rome there are three studios, in Turin one, and in Milan there are five. Programs come from these one after another during the afternoon and evening.

In Milan, three of the five TV studios are converted radio studios. The fourth is a theatre, seating 500, for TV use exclusively (there are very few audience pro-

grams). The fifth studio is 20 by 30 meters (65 by 97½ ft), which makes it the largest studio in all of Europe. It is from here that the large opera productions are put on.

Mobile TV Units

For remote programs seven large mobile TV units mounted in 36 to 39-foot trucks are used by RAI. Each contains three TV cameras, sound and control equipment, also recorders and relay equipment. Milan and Turin have two each of these mobile units, and Rome has three.

Studio Control

According to RAI philosophy the camera control operations are separated from the switching and mixing operations. In the arrangement of control operations for studio 3 in Milan, for example, the camera controls are in a totally enclosed room on the first floor. The audio and video switching are on the second floor overlooking the studio through large windows. In the video area sit the producer (director), script girl, and the technical switching man. In the audio area there is a Maestro



FIG. 13. Transporting an RAI mobile TV unit through the "streets" of Venice.



FIG. 14. The RAI mobile units travel far afield in all kinds of weather. Here the 1956 Olympic winter games are being televised.



FIG. 15. Ing. Liverani and Marchese at audio switcher designed and built by the RAI engineers.

(for operas and musicals) sitting beside the audio operator.

In the production of live musical shows such as operas the sound is recorded prior to the performance, then played back—both during rehearsals and during the actual on-air performance. By this means the Italian producer and Maestro believe they procure more perfect sound reproduction. Also it is believed that better video production is obtained since there are neither microphones nor shadows caused by sound equipment to contend with. It goes without saying that in a production as involved and requiring as many separ-

rate sets as an opera the elimination of impediments does ease the video job. That better sound is obtained by this method would be questioned by many.

With regard to separate recording of sound, here is room for wide divergence of opinion. This procedure can create more problems than it solves. The difficulty of achieving lip sync with sound playback is a foremost problem. As we watched *Cavalleria Rusticana* on the TV screen, there were easily noticeable times when synchronization was not achieved. Twice it was definitely disconcerting. When camera action and lip sync were achieved, it was a superb performance.

Eurovision TV

The RAI system connects into the all-Europe TV network, known as Eurovision, by means of microwave relay. Co-ordination center for the Italian segment of the Eurovision network is located in Milan. The technical co-ordination center for the entire Eurovision system is in Brussels, Belgium.

There are four Swiss stations in the system, six German, six covering Holland, France and the Netherlands, and one in England. In France and England conversions must be made since they do not employ the standard CCIR European system.

Italy employs the CCIR system of TV. This consists of a 625-line picture run at a frequency of 25 frames (50 fields) per

second. England employs a 405-line, 50-field system, while France uses 819 lines and 50 fields.

TV Transmitting Stations

The original RAI TV system consisted of five stations with studios at Rome. Now, there are 9 primary stations, 15 secondary stations and 12 automatic repeaters in the RAI system (as of this writing, October 1956) with studios in Turin, Milan and Rome. It is planned to cover all of Italy and Sicily by 1957 with a total of 77 stations.

The 9 primary stations are powered by 4 to 10 kw transmitters, while the 15 secondary stations use 1/2 to 1 kw transmitters. Antenna gains cover the range shown in the following table:

Primary Stations in RAI System

Location	Power	Antenna Gain
M. Penice	10 KW	10 (irregular pattern)
M. Peglia	1 KW	15 (irregular pattern)
M. Faito	5 KW	10 (irregular pattern)
Turino	5 KW	7 (circular pattern)
Milano	4 KW	8 (circular pattern)
M. Venda	4 KW	20 (irregular pattern)
Porto Fino	4 KW	20 (irregular pattern)
M. Serra	7 1/2 KW	26 (irregular pattern)
Roma	7 1/2 KW	10 (irregular pattern)

The 12 automatic repeater stations employ 5 to 250-watt TV transmitters with antenna gains of 8 to 10. These stations usually cover an area of irregular shape with longest radius up to 25 kilometers (15.5 miles). These stations are actually translators, that at Brunate for example, picks up the on-air signal from M. Penice (approximately 75 air-line miles away) on channel one and rebroadcasts it on channel five.

Radio Relay System

The 9 primary stations are linked together by 7 to 20-watt radio relays. Many of these stations are on high mountains such as M. Penice, 1300 meters (4225 ft) high. Links run over various distances, for example, between M. Penice and Milan 86 km (53.4 miles) and between M. Penice and M. Venda, 200 km (124.2 miles).



FIG. 16. Typical 3-channel FM and 1-channel TV repeater (translator) in Northern Italy. Many repeaters are used for both the RAI radio and the TV system to serve small local communities.

Monte Penice Transmitting Site

At Monte Penice, a typical transmitting site some fifty miles south of Milan, is a TV and FM broadcast transmitting station. Three 10 kw FM transmitters are employed using a single antenna for the three program channels. The TV transmitter here is the largest in the RAI network. It consists of an RCA Type TT-10AL, with 10 kw visual and 5 kw aural output. According to Transmitter Engineer Alexandro Galeazzi, the TT-10AL is a "very good transmitter—the best of all we have." This statement was echoed by the Chief Technical Director of RAI in Milan, Ing. Andrea Magelli. Furthermore, he added that the RCA unit is not only the best transmitter in all of Italy—it is also the most reliable.

The relay system at M. Penice makes

contact with M. Venda to the east and Milan to the north. It is a two-way system with signals going in both directions.

VHF voice communication links are also employed between relay stations. At M. Penice, for example, private RAI phone communication links are available to M. Venda and to Milan.

Commercial power supply is available at M. Penice the same as at other mountain-top locations. Power comes in at 27,000 volts and is reduced to 220 volts for operation of equipment at transmitter site. Three transformers are used in the supply system: No. 1 powers the FM and TV transmitters and relay equipment, No. 2 is a spare for emergency purposes, and No. 3 supplies power for lighting, etc. All radio and TV equipment is designed for 220 volt, 50 cycle operation.

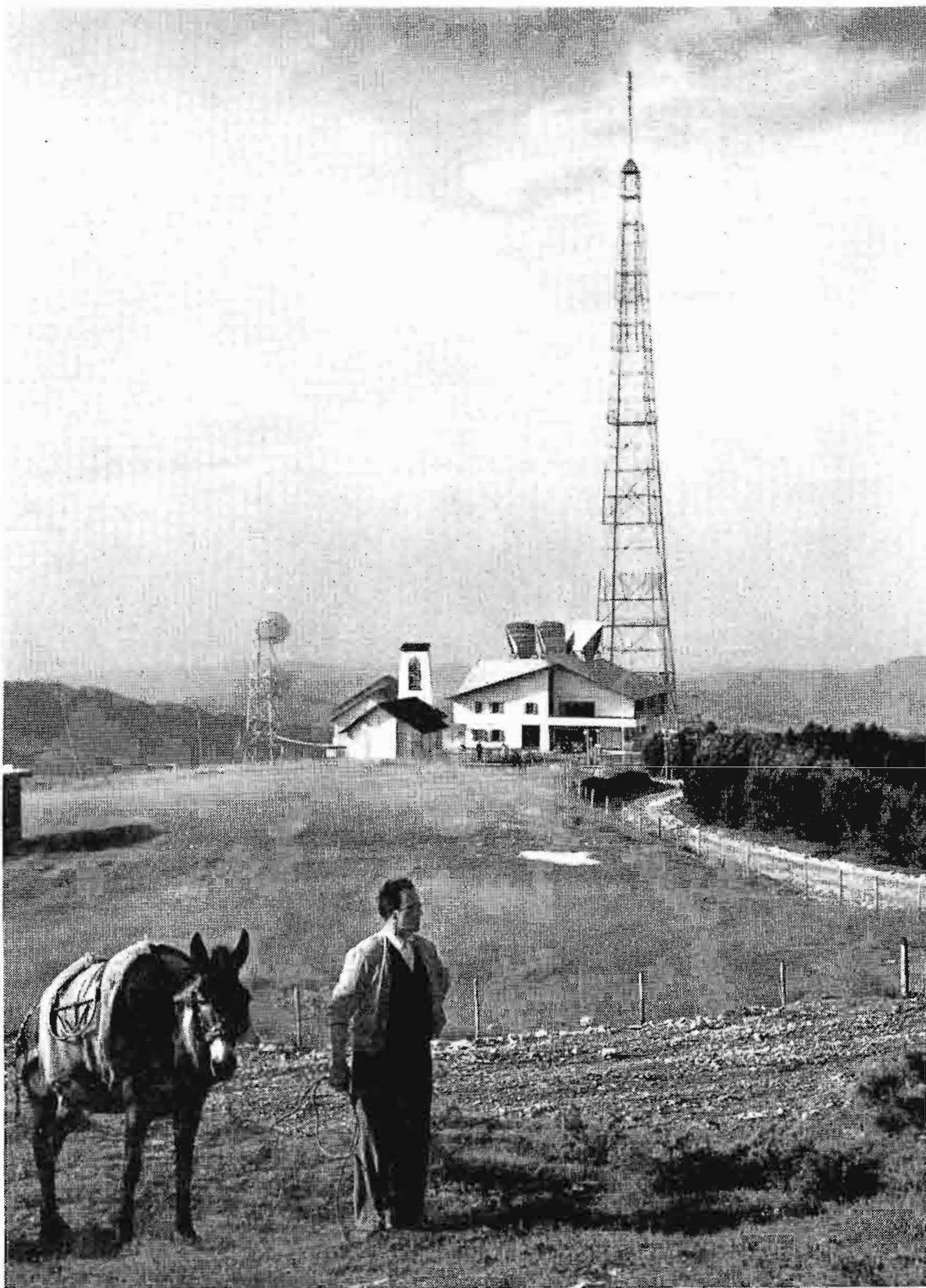

FIG. 17. Monte Penice in Northern Italy is the site of the TT-10AL TV transmitter. (Note church to left of transmitter building.) RAI personnel live in here six days a week.

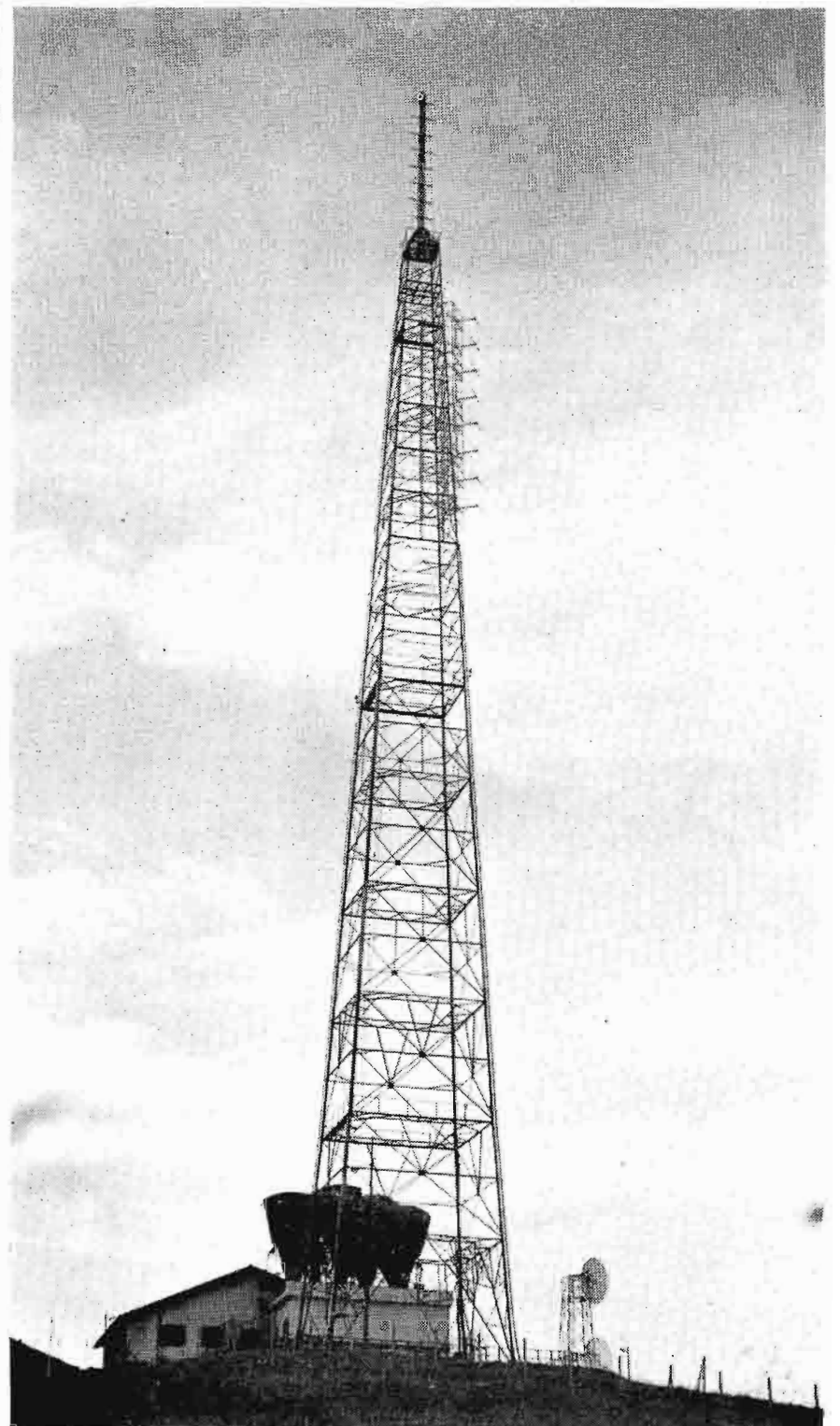

FIG. 18. Radio relay at right is telephone company link. Antennas for TV relay link to Milan and M. Venda are mounted on roof of transmitter building. Tower supports both FM and TV antennas.

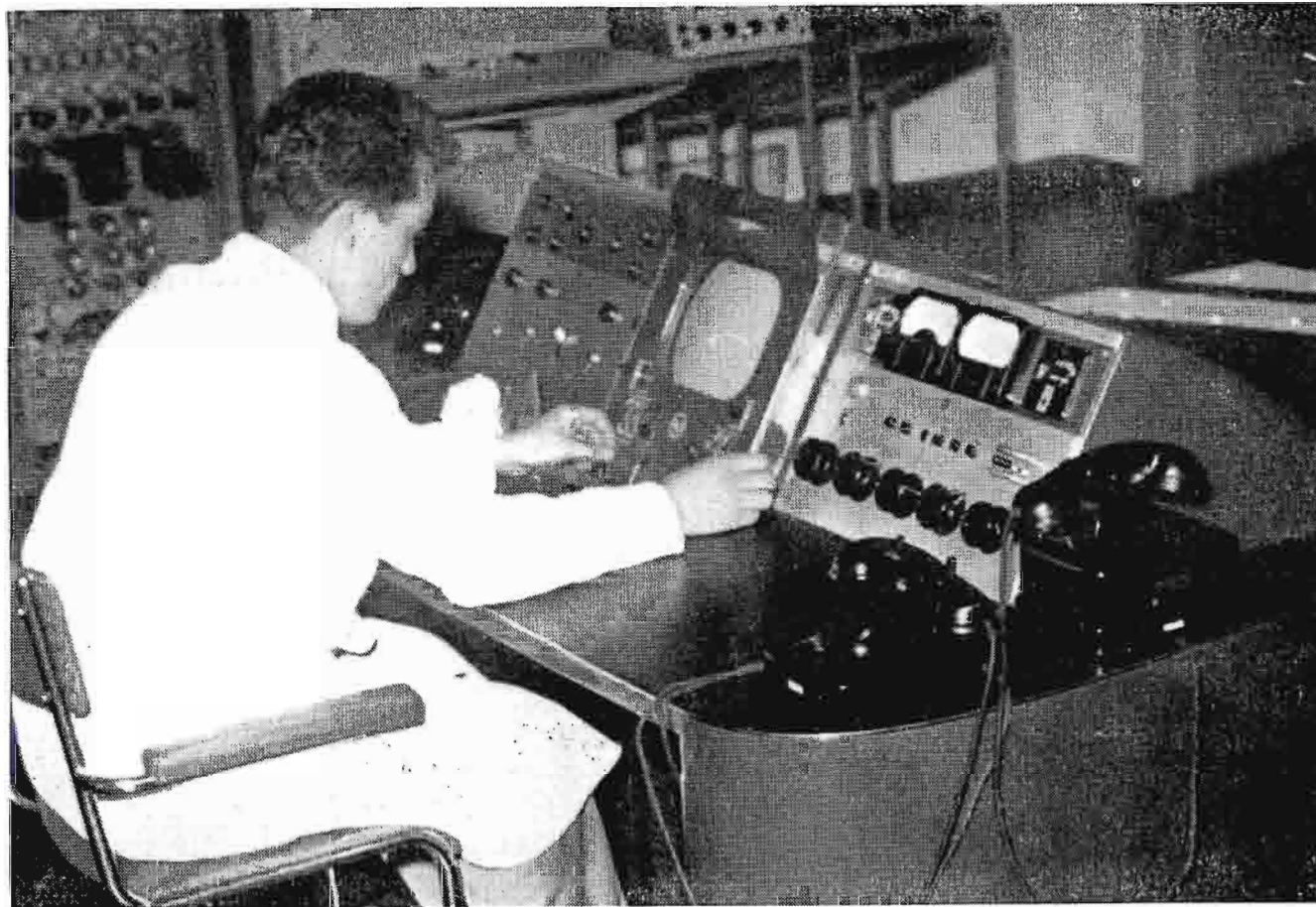

FIG. 19. Operator Benito Chiucchi at TT-10AL 10-kw TV transmitter control console.

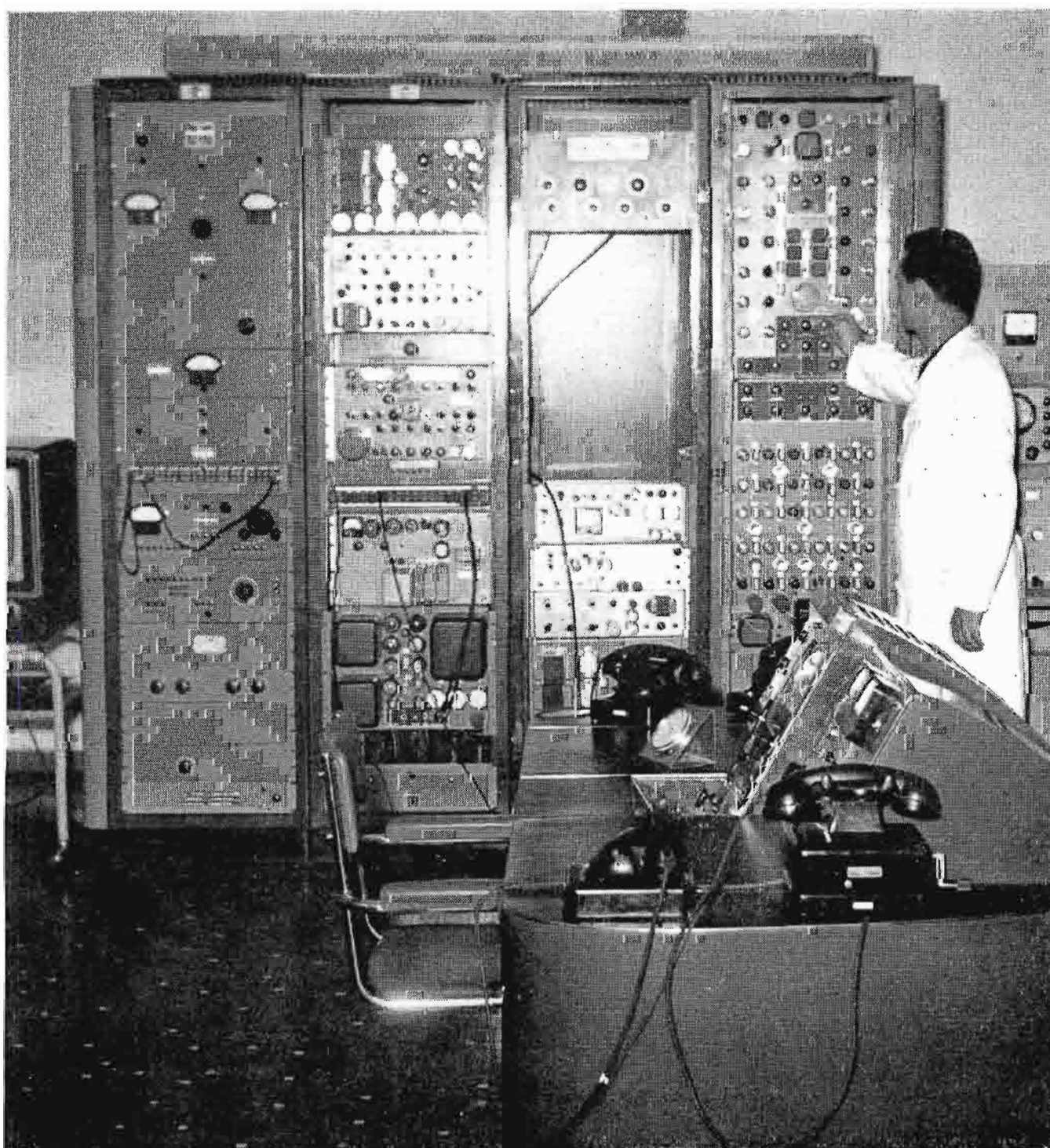

FIG. 20. Second operator Adani Rino at sync generator rack in M. Penice transmitter room.

An emergency power room at M. Penice contains two generating units. They are gasoline powered to deliver 93 kw to power TV and the relay transmitters, and 60 kw to power the radio transmitter. The total is sufficient to power all equipment at the transmitter site.

Engineering Personnel

At a typical transmitting site, such as M. Penice, a total of nine men are engaged. They work six days weekly and all live in. Roads are difficult to travel and the location is fairly remote. There is one shift only, which is 7 hours, 15 minutes daily. The operators take turns working on Sundays.

A typical studio in Milan using three TV cameras employs eight men: three on cameras, one video switching, one audio control, two video control, one sound man at studio microphone.

The entire RAI engineering staff is under the supervision of Ing. Bertolotti, Chief Engineer, who is located at RAI headquarters in Rome, while a complete staff is located in each of the large studio centers. At Milan for example the Chief of Staff is Ing. Mauri and under him the Chief Technical Director is Ing. Andrea Magelli, Chief Studio Engineer, Ing. Pierfrancesco Liverani; Transmitter Engineer-in-Charge, Ing. Alexandro Galeazzi; and Engineer-in-Charge of Relays, Ing. Lari.

Typical TV Translator

At Brunate, near Lake Como in Northern Italy, is one of some 65 projected "automatic repeater" stations as they are called. These are used both for FM and TV. Here three FM receivers are used to pick up radio signals from the strongest nearby transmitter. (A spare receiver is also on hand.) These three receivers modulate three FM 200-watt transmitters, designed and built by RAI engineers.

For handling rebroadcast of the TV signal two repeaters are employed. Number 1 is used on one day, number 2, on the day following, and so on. The switching from one to another is done automatically, since these stations are unattended. Also in case of emergency the unused repeater is automatically switched in.

Each repeater consists of a receiver unit, a conversion unit, and a transmitter unit. The off-air TV signal is received at Brunate on channel one and retransmitted on channel five. By this means the local area is served.

The output of the Brunate TV automatic repeater is 5 watts, but there are in

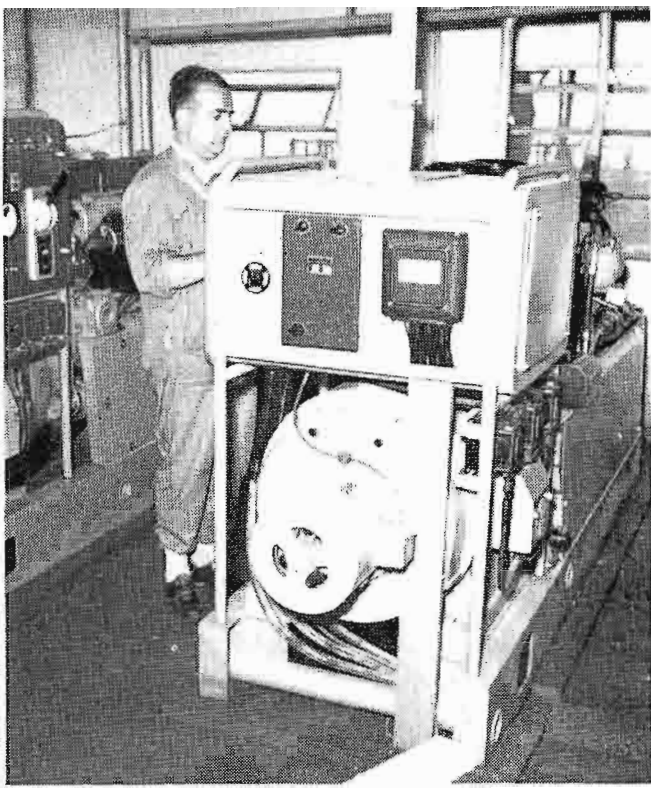

FIG. 21. Two emergency power units of 93 kw and 600 kw are available to power TV and radio equipment at M. Penice transmitting site.

Italy also 50 and 250-watt TV automatic repeaters. The power supply at Brunate is furnished at 380 volts a.c. by the local electrical society and there is no emergency power. (Emergency power, furnished by gasoline-powered generating units, is available only at the primary stations.)

Both radio and TV repeaters are turned on and off automatically by means of an electrical clock. The automatic repeaters in Northern Italy are serviced by a crew of four technicians working out of Milan. Two technicians work inside to construct the equipments while the other two travel to the various sites to maintain them in operating order. Visits are made twice a month to each site.

Conclusion

Some 7000 persons are employed in this huge state-wide operation: 3000 in Rome, 2000 in Milan, 1000 in Turin, and the remainder scattered about Italy. Almost half the total number of employees are engaged in the TV operation. RAI engineers have designed and built a considerable amount of their TV equipment, including monitors, audio control consoles, and video switching equipment. They also build FM transmitters, TV translators, and home TV receivers. The largest TV transmitter used by the RAI is the TT-10AL 10-kw unit.

According to the RAI some 350,000 sets are now in use in Italy. Popular American makes as well as Italian sets are sold. This makes Italy the second most popular TV country in Europe (Great Britain occupies the number one position in Europe).

However, TV coverage in Italy is probably one of the best planned of any we have seen and is being most ably executed by the RAI engineers according to their master plan. It only remains for programming to become more versatile and to offer more choice of channels in order to build a big booming industry.

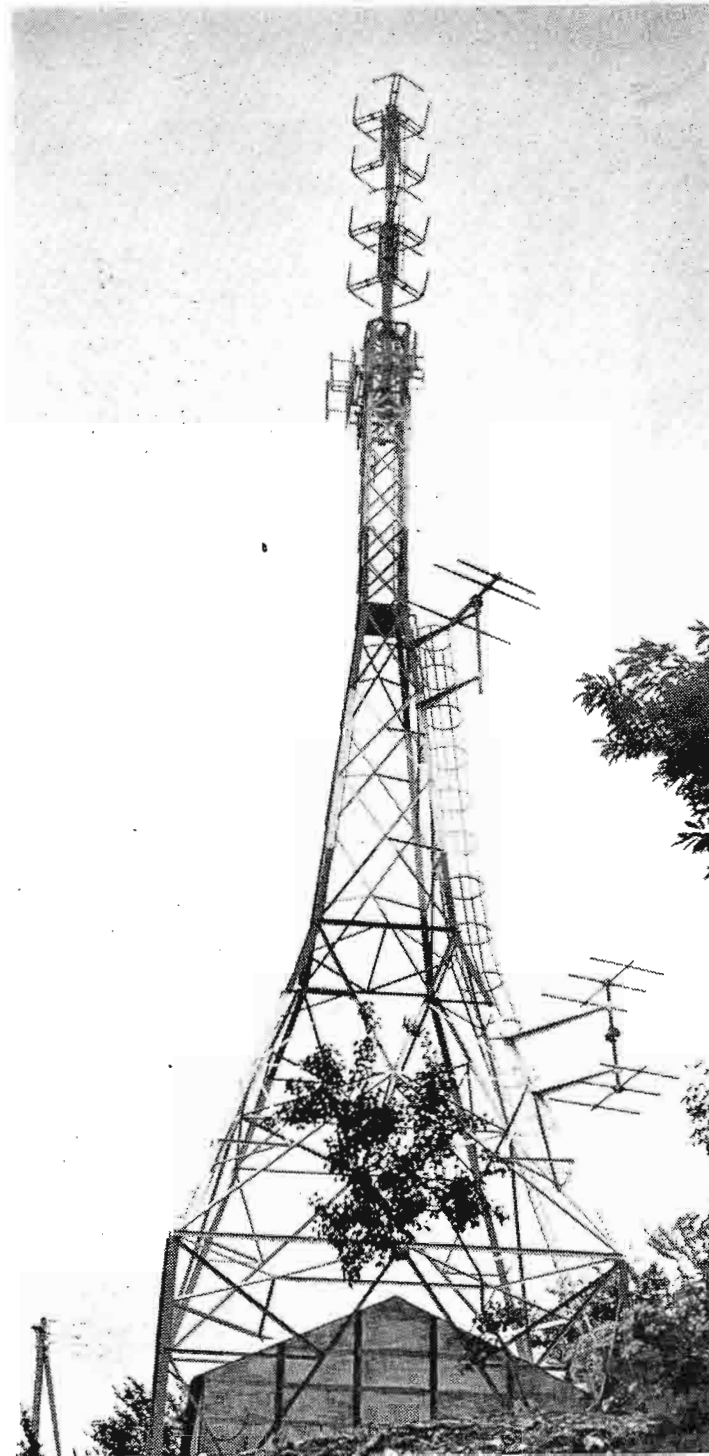

FIG. 22. Typical RAI automatic repeater (translator) for FM and TV at Brunate in Northern Italy.

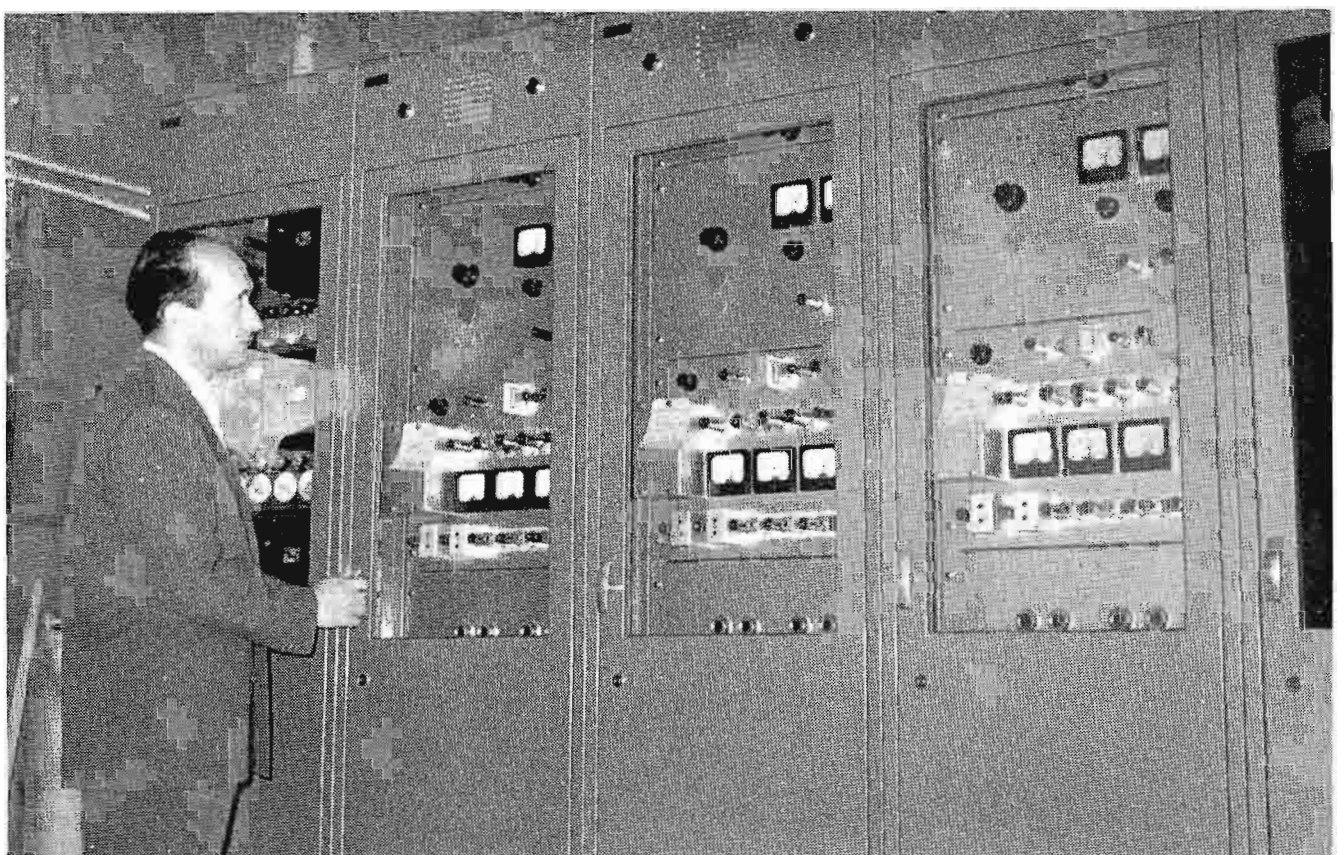

FIG. 23. Ing. Galeazzi at one of three FM transmitters built by RAI engineers and used in Brunate automatic repeater station. Radio system is 3-channel; TV, 1-channel.

HOW SK&F USES COLOR TELEVISION

Presents Surgical and Clinical Procedures at Scheduled Conventions to the Medical Profession

by PAUL A. GREENMEYER*
and PAUL C. SCHMIDT**

* Managing Editor, BROADCAST NEWS
** Assistant Television Unit Manager, Smith,
Kline & French Laboratories, Philadelphia

FIG. 1. Color TV Mobile Unit employed by SK&F to televise clinical and surgical procedures. This unit contains equipment for controlling and switching two color cameras. The cameras, projectors, microphones and cables are transported in the truck and set up on arrival at demonstration hospital.

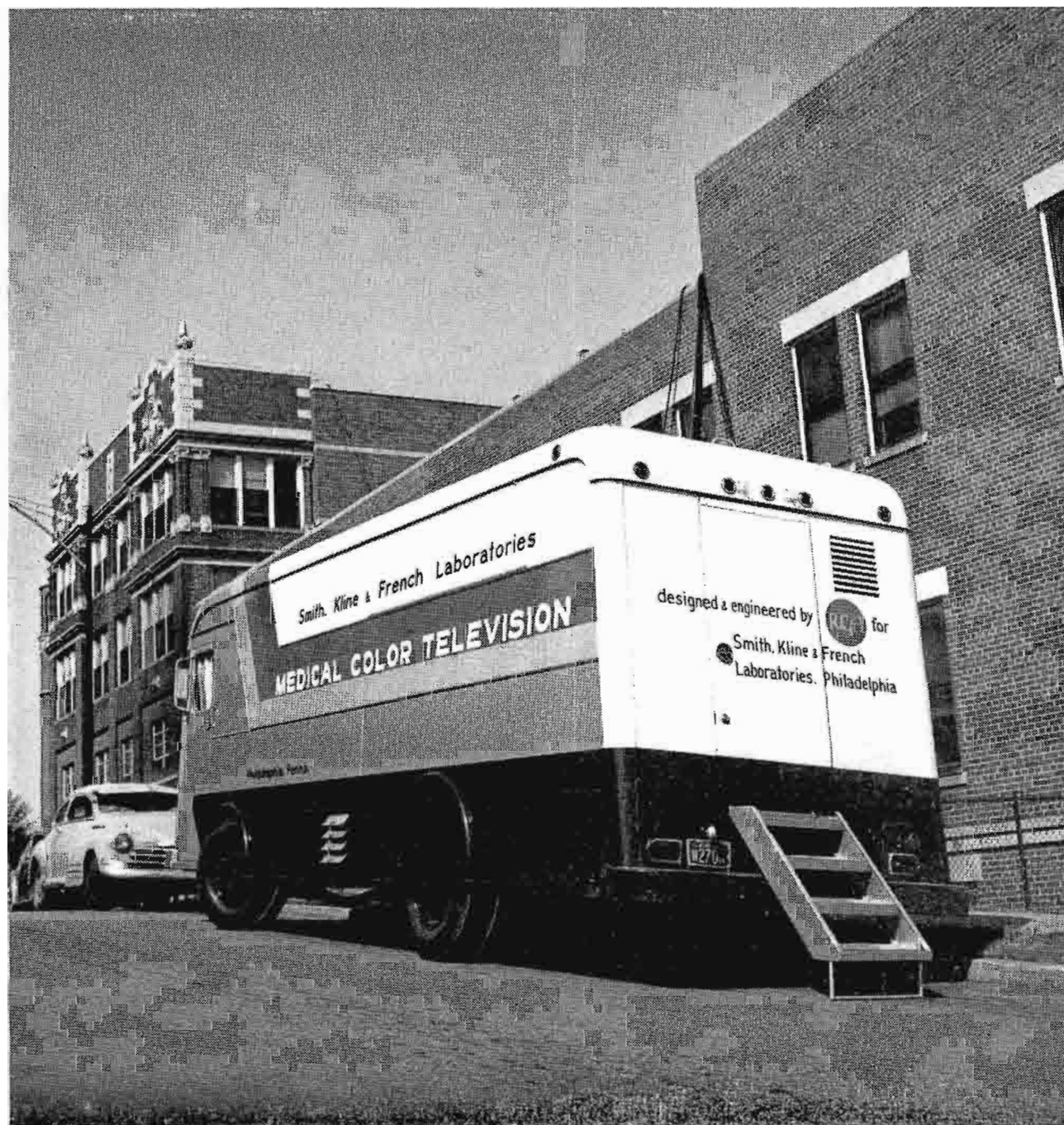

Since June 1949, Smith, Kline & French Laboratories, Philadelphia, pharmaceutical manufacturers, have been presenting live color television programs at meetings of the American Medical Association. At the outset field-sequential equipment was employed but recently a complete RCA compatible color TV system has been acquired. This is an account of the first use of the new system, at the Fall Conference of the Kansas City Southwest Clinical Society, September 25 to 27, 1956.

Best Type Medical Instruction

Typical was the comment of the moderator at the Operative Clinic on Herniorrhaphy, who expressed gratitude to SK&F for presenting the "best type of medical instruction seen by this society." He further commented that the new equipment (RCA) being used by SK&F presented a larger and brighter picture. He said that it is the best demonstration we have seen of surgical procedures and the best view of an operative site.

The SK&F Medical Color Television Unit was organized for several reasons, among which the following are probably the most significant to the medical profession and to educators:

1. To provide otherwise unobtainable close-up views of "live" surgical and clinical procedures for hundreds of viewers simultaneously, and
2. To promote the use of color TV as an aid to medical education.

Under the leadership of Lewis M. Lang, manager of the Color TV Unit, SK&F has presented 1138 clinics and 705 surgical procedures over a period of seven years.

Survey results obtained by SK&F from 1000 questionnaires reveal that 98.4 per cent of televiewing medical doctors favor including TV in the meeting program; 81 per cent prefer color TV clinics to platform (or auditorium) clinics; 84 per cent prefer to view surgery on color TV rather than from an amphitheater; and 70.5 per cent prefer to watch televised live operations rather than color film.

Mobile TV Equipment

A 28-foot truck furnished by RCA contains all the equipment used for the compatible color TV medical presentations. Most of the control and switching equipment is permanently mounted in, and operated from, this truck. Cameras, projectors, microphones and cabling are transported in the truck and set up upon arrival.

This is the only traveling medical color TV unit known to be in existence. Both the production and the technical staff are full-time employees of SK&F, and all the TV equipment is owned by SK&F.

The equipment includes two Type TK-41 color TV studio cameras, one Type TK-45 surgical color camera, two 4½ x 6-foot color TV picture projectors (see Fig. 3), and all the necessary control equipment.

How the Equipment Is Used

The TK-45 surgical color camera is a new and exclusive piece of equipment, being designed especially for use in operating and autopsy rooms. Ordinarily it is installed in a ceiling mount out of the way of the operating doctors. It focuses directly on the operating field by means of a mirror that reflects down through an opening in

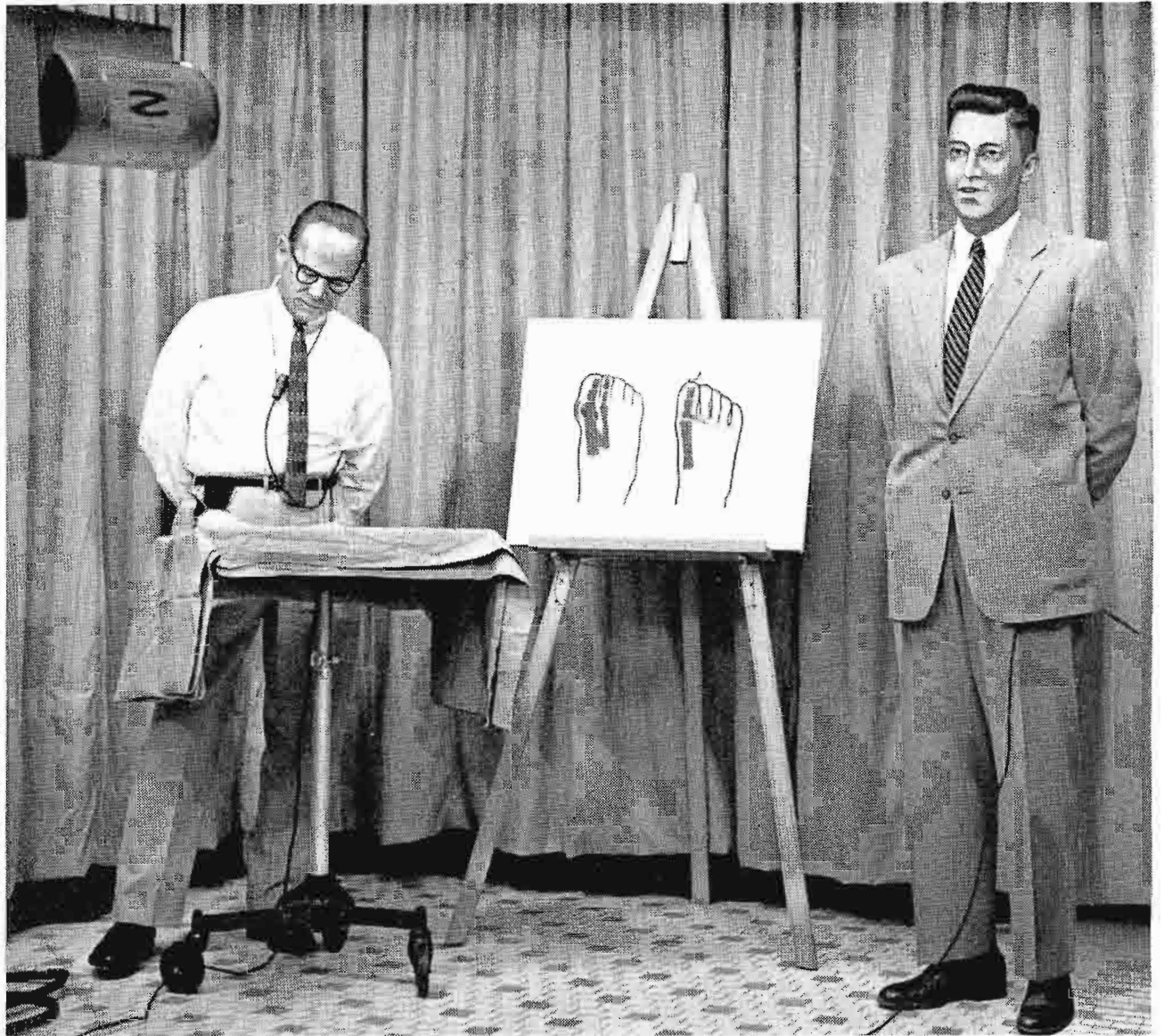

FIG. 2. Typical clinical demonstration televised by SK&F from portable studio set up in Kansas City General Hospital No. 1 at Fall Conference of the Kansas City Southwest Clinical Society, Sept. 1956.

FIG. 3. Audience of several hundred doctors attending Conference view the Color TV pictures miles away from hospital on a large screen. The RCA Telemural Projector, Type TLS-50, is being used for this demonstration.



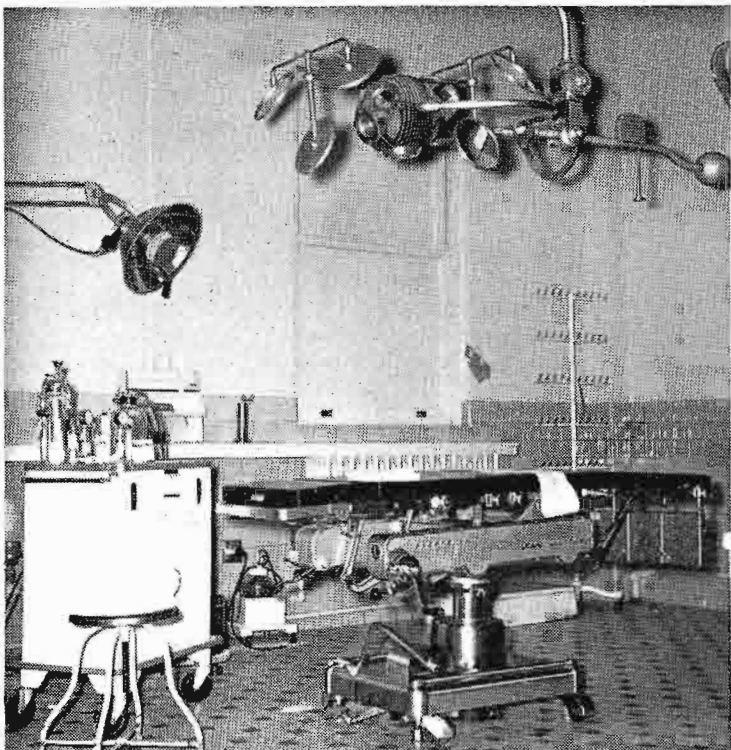

FIG. 4. Spare operating room in hospital is used for setting up studio.



FIG. 5. Same room as it appears when portable drape holder and lights are being installed.

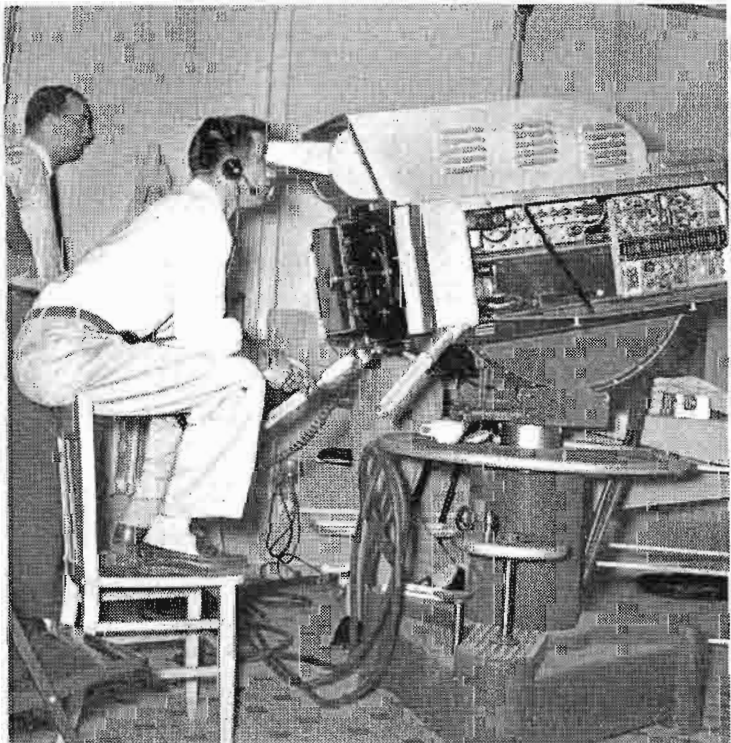

FIG. 6. Setting up TK-41 Color TV Camera to use in the studio for dry clinics.

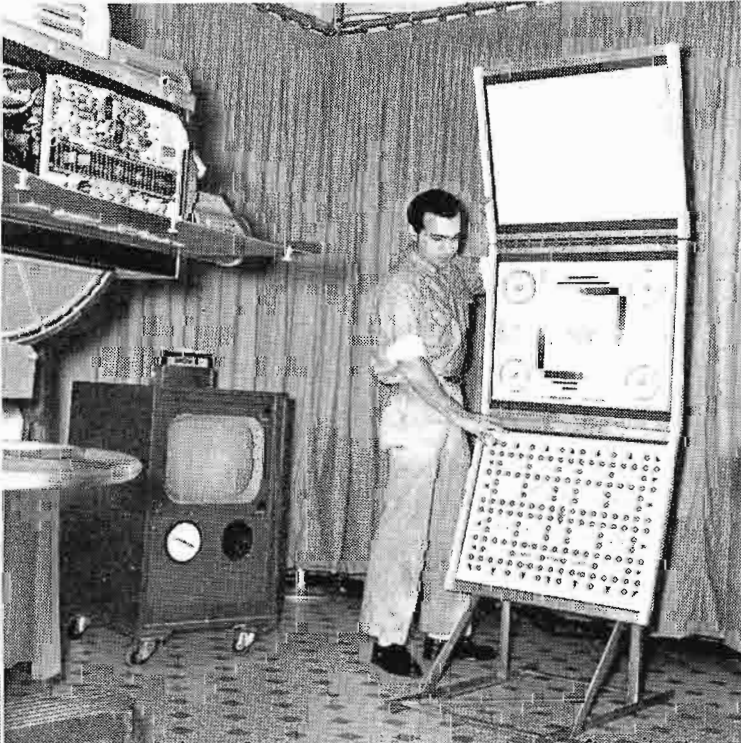

FIG. 7. RETMA charts, used for aligning cameras, are mounted on a portable, folding frame.

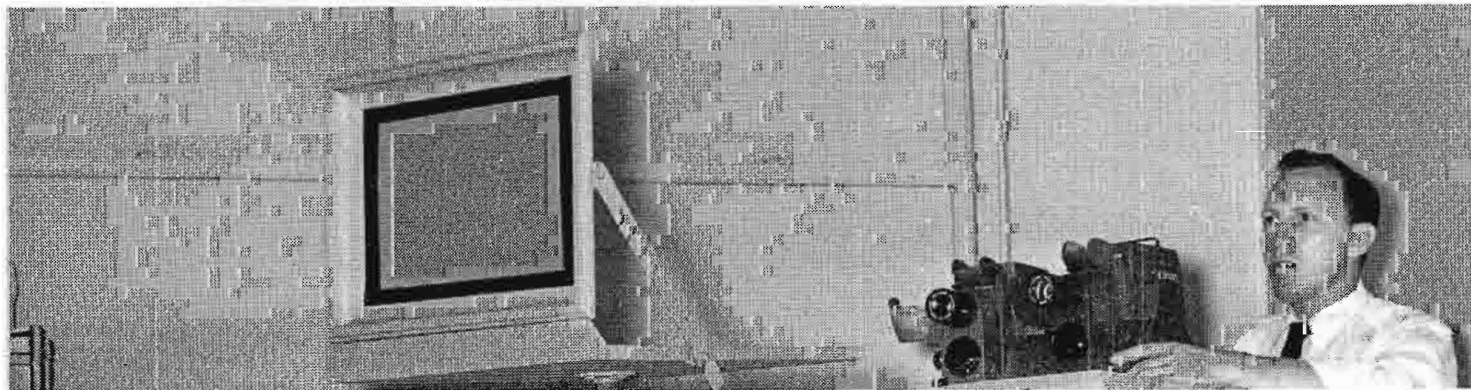

FIG. 8. Small screen is used for rear projection of 35mm slides to be integrated into program. A Color TV Camera is then focused on the screen.

the medical lighting fixture. For SK&F demonstrations, which require portable equipment, this camera has a special boom mount that carries the mirror high above the heads of the surgeons. In this way the camera can be effectively employed for demonstrating surgical procedures.

The two studio cameras are used for demonstrations and presentations that take place in an area other than the operating room. Usually a nearby room is made over into a studio in a few hours by means of portable drapes and other studio accessories. A control console for the SK&F program director is placed nearby.

The color TV picture projector and screen are installed in the auditorium where the meetings are held. Frequently the auditorium is several miles from the hospital where the program originates and this was the case with the presentations at Kansas City. The program origination point was the General Hospital, while the viewing doctors were at the Municipal Auditorium. Hospital and auditorium were connected by a temporary microwave radio link set up by the local telephone company.

The program is arranged so that there is two-way communication between hospital and auditorium. Doctors in the audience at the auditorium can pose questions to the surgeons and other participants at the hospital demonstrations. A moderator at the auditorium reads the questions which are then heard by the participating doctors at the hospital. They are answered immediately and heard by all in the auditorium.

Personnel of TV Unit

The SK&F Medical Color TV Unit comprises a total crew of 12 men—a 4-man production staff and an 8-man technical staff. The production staff includes: manager, assistant manager, program director, and program co-ordinator. The technical staff includes: chief engineer, assistant chief engineer and six technicians.

Operating Positions

When a "show" is being run, the program director operates from the "studio." The program co-ordinator works on the studio floor with doctors—acting as floor manager. The manager and assistant manager may be at the studio, the TV truck, or the auditorium—wherever needed to handle administrative problems.

The chief engineer is at the auditorium watching the picture on the screen and controlling the quality by telephone line to the truck. Here is one type of program

FIG. 9. Miniature rubber models are used to orient audience prior to presentation of a surgical procedure.

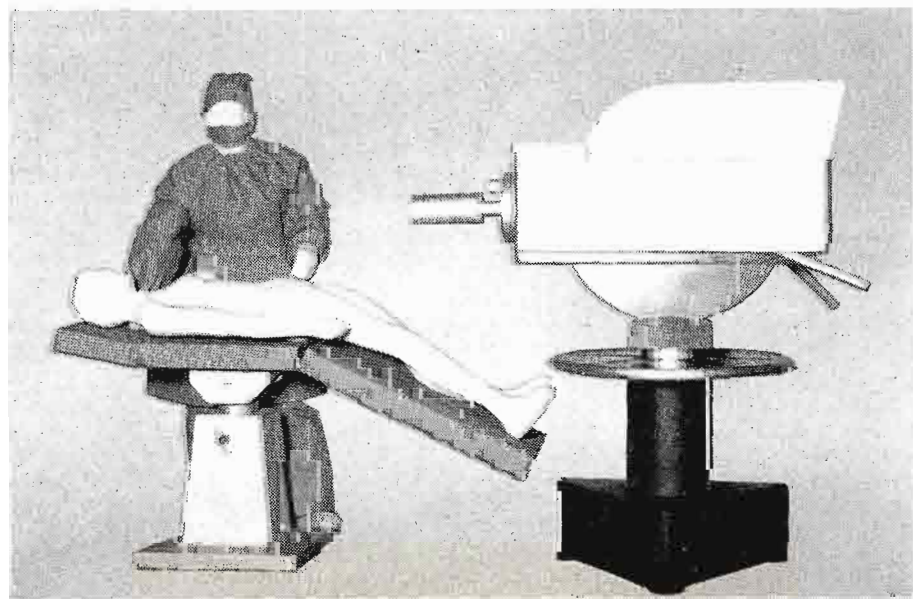

in which the engineers have absolute control of the received as well as the transmitted picture. Any idiosyncrasies in the telephone line (microwave link) or any other maladjustment can be compensated for in order to produce an ideal picture.

The assistant chief engineer acts as technical director, in the truck, where he operates the switching equipment. Two technicians operate the studio camera controls in the truck. Three technicians are cameramen—one for each TV camera. The sixth and last technician is at the control console of the medical camera which is in or near the operating room.

Setting Up

Each program is arranged at least one year in advance of presentation. An orientation meeting is held for all participants four weeks before program date. Individual meetings with each doctor and each lay participant are held one week before the program begins.

The TV truck is scheduled to arrive at the hospital well in advance, in order to allow two days for technical setup time and several days for rehearsal. The amount of time required for rehearsal depends upon the duration of the program, and since programs run anywhere from two to five days, rehearsals range from two to four days.

By correspondence and telephone, preparation for the technical setup has been arranged beforehand so that power is available, telephone lines arranged for, and microwave facilities provided. Accessories for the studio and all other production equipment are shipped (via furniture movers) to arrive several days in advance of set up time. Thus, when the TV truck arrives, its crew can immediately connect the cables, set up the cameras, plug in the power and proceed to get a picture.

Special Cabling

To help speed the job, composite cables have been designed by SK&F engineers. Each consists of a Teflon sleeve containing numerous audio and video lines. Four of these are used. One contains all audio—6 microphones. The second contains all video: 3 monitors, 2 line monitors, and tally lights. The third contains audio and video lines to and from surgery. The fourth contains the video pulses for genlock to the medical color camera. A grand total of 17,000 feet of cabling is employed (including 9000 feet of RG11) and of the total, 7000 feet is audio and the remaining 10,000 is video cable.

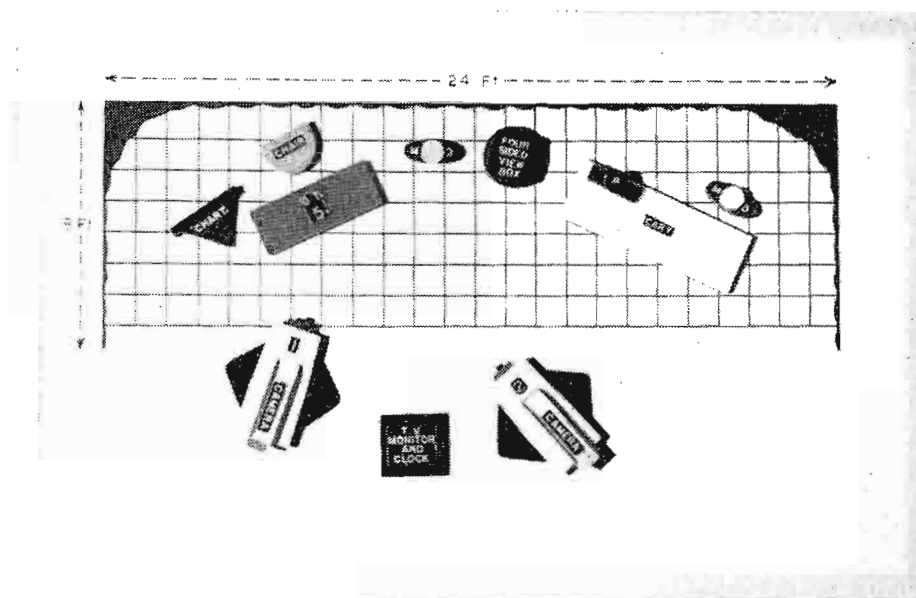

FIG. 10. Floor plan with miniature representation of carts, beds, tables and personnel enable doctors to plan studio presentations rapidly.

Programming for Medical Presentations

As a result of considerable experience in presenting some 90 programs consisting of 1138 clinics and 705 surgical procedures the SK&F production staff has formulated a rather successful and standardized type of format for medical TV demonstrations.

Professional programming is the key to this tried and proved concept. A studio for orientation, introduction, auxiliary materials, and formal close is a basic essential to the format. Commercial TV equipment with all the devices, controls and special effects used by the broadcaster are employed. Finally, but most essential, expert counsel is given to the participating doctors in order to guide them into making an effective presentation.

Professional Programming Assistance

Production personnel at SK&F under supervision of John Mackenzie, Program Director, have written a comprehensive

manual entitled "Medical Color TV Information" to guide doctors in making an effective presentation of their subject. This manual covers such subjects as:

- Clinical Presentation
- Panel Discussions
- Special Effects
- Surgical Presentation
- Chart Techniques
- Patient Release Forms
- Production Pointers
- Sample Cue Sheet Outline
- Studio Equipment
- Visual Aids

The manual explains the purpose of the studio. It reminds the doctor that auxiliary material is often needed for complete understanding of a surgical procedure but would often hamper the surgeons if presented from the operating room. The doctor is reminded that such material can be presented much better from a studio. Here are cameras and other apparatus designed

FIG. 11. Note box containing five microphone inputs used for participants at demonstrations in the studio area.

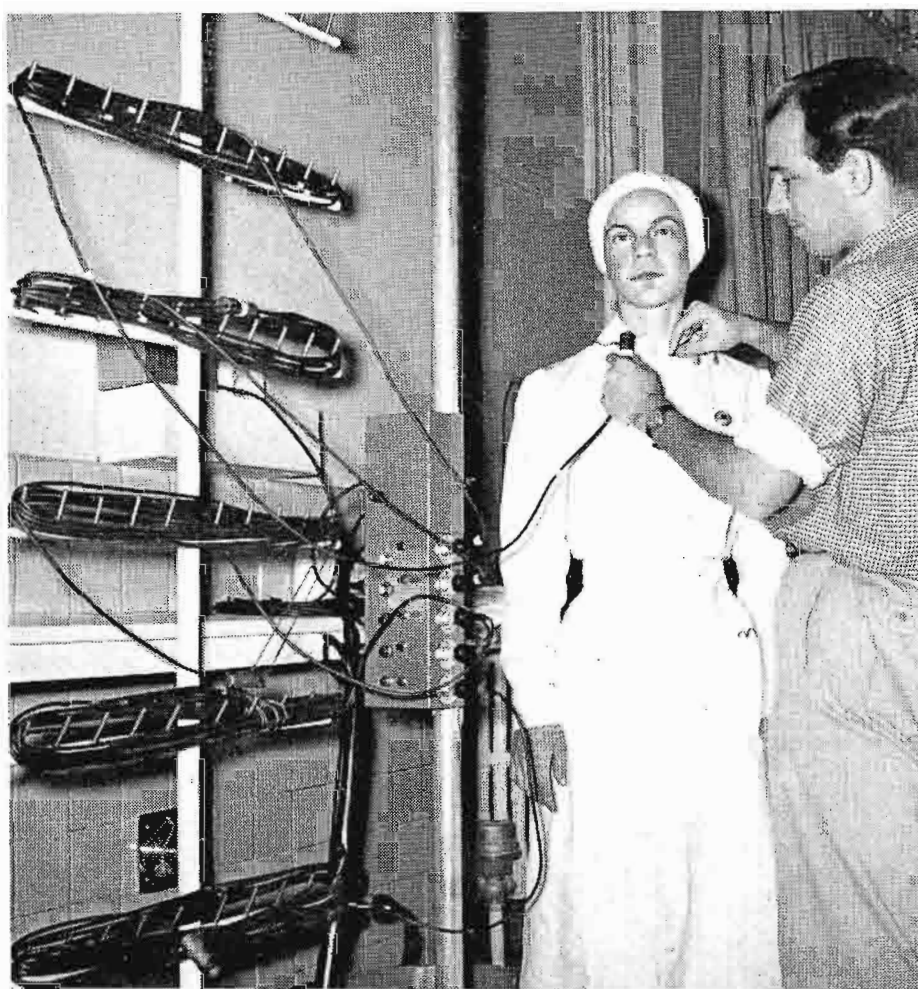

FIG. 12. Video and audio cables from hospital connect to mobile unit through built-in connector panel.

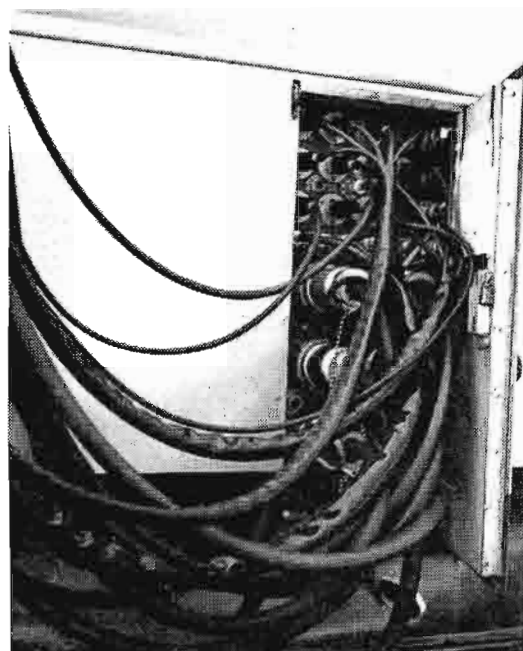

FIG. 13. Mobile unit is parked alongside hospital and connected to studio and power supply via cabling carried in the truck.

FIG. 14. Power and telephone lines connect to mobile unit through built-in terminal facilities.

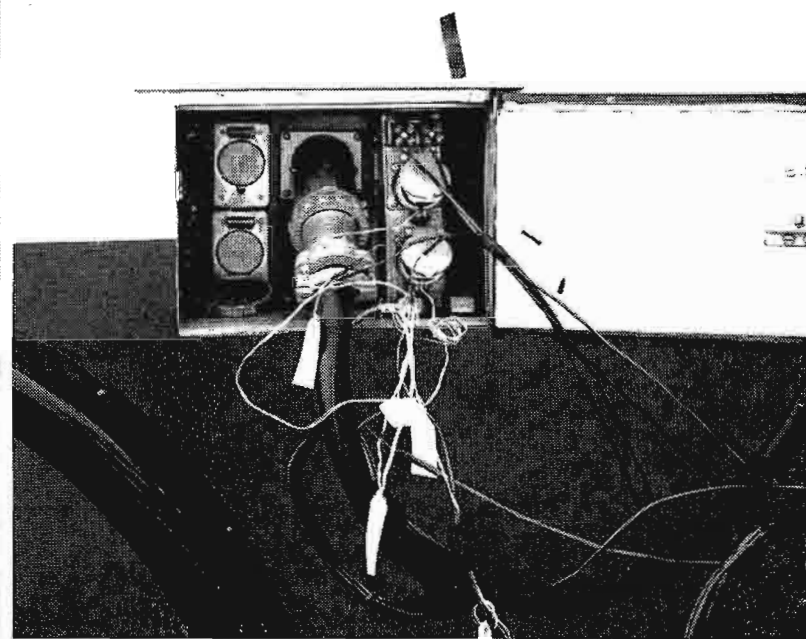

FIG. 15. SK&F chief engineer sits alongside of TV projector operator in order to have advantageous position for controlling picture quality via telephone line to mobile unit.



to make it easy to present such materials as charts, X-rays, slides, and visual aids. Surgical instruments, models, and cue sheets in the studio all help to make the presentation more meaningful. The studio can also be used for the introduction, for necessary explanations while switching from one operating room to another, and for the formal closing.

Lighting

Thirty-three lighting units are carried. Twenty are 500-watt spots, 10 are 50-watt floods, another two are surgical lights of 150 watts each. The last are for use in the operating room to supplement normal surgical lighting. They are mounted on floor stands and equipped with color-correcting filters. The last lighting unit is a 750-watt Alt spot equipped with numerous color insert discs.

Slide Projection Facilities

SK&F production personnel prefer 35mm slides because of ease of handling. A special small rear-screen projection stand with 9 x 12-inch screen has been devised for slide presentation. Two 35mm projectors are mounted atop a convenient packing case about five feet behind the screen. In presenting slides they can be full screen with the doctor giving a running commentary, or a doctor can stand beside the slide with pointer to make this portion of his presentation. (See Fig. 8.)

FIG. 16. Color TV cameras are mounted on foam rubber and strapped to dollies for storing in mobile unit and for ease of transportation to hospital studio area.

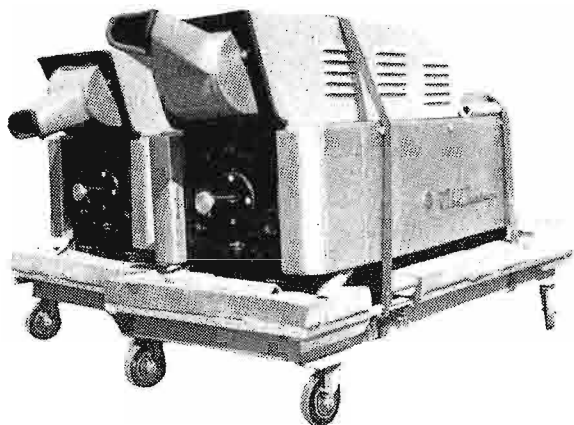

Setting Up Studio

The complete TV studio includes backdrop frames, drapes, lighting bridge, lights, and slide projectors. A room near the operating suite is usually chosen for the studio (this may be one of the operating rooms). Once the room is available, the portable frames for drapes and lights are set up. These are aluminum tubing and strut supports, easily assembled and disassembled. Power and microphone termination boxes are fastened to the frames. Lights are placed and drapes are hung.

The two live color cameras are assembled and cabling is connected. A special monitor in a 30-inch cabinet on wheels is rolled in. This also contains a large clock with sweep secondhand and a loudspeaker. The clock reminds the doctor of the timing and the loudspeaker brings questions from the auditorium.

Portable chart holders are used for aligning the cameras. These are of aluminum angle construction, on wheels, and hold the three standard RETMA charts: registration, resolution, and linearity. To expedite alignment two chart holders are used so that both studio cameras can be lined up at the same time.

Special Program Effects

In guiding the doctors to make the ideal type of presentation the SK&F TV special-

ists give specific examples of how to employ such professional effects as superimposition, split-screen, corner insert and chart wipe. In the case of superimposition the example given consists of using a transparent model of the human torso with a heat generator for a heart. As pulses of the heat generator vary, the wave patterns on an electrocardiograph vary correspondingly. During the program, it is suggested that the wave pattern be superimposed over the transparent model for maximum effect. Similarly, concerning the use of the split-screen device it is suggested that showing the effect of a procedure on a patient and, at the same time, an enlarged view on a model, using two cameras, can be more telling. Illustrations are likewise given for use of corner inserts, chart wipes, and many other effects. By this means the doctor's imagination is fired, enthusiasm develops, and a far more effective program is the final result.

Anatomical Orientation

Here is a typical example of the ingenuity exercised in order to properly prepare the audience for a surgical procedure. It involves three small models which have

been created by SK&F production personnel. One is a figure dressed to represent the surgeon—complete with cap, gown and mask. Another is a figure with ball-and-socket joints to permit duplication of any position assumed by a patient in surgery. The third is a miniature model of an operating table. These three are used to orient the audience during the opening remarks so that they can picture the position of the patient and are also used after a studio shot during which time the position of the patient has changed (Fig. 9).

Program Planning

To assist doctors in planning for studio presentations a series of miniature cutouts and a floor plan have been developed by SK&F program personnel. The use of these shows exactly how many carts, beds and other items can be accommodated in the room selected for the studio. It assists greatly in planning the programs by showing what can be accommodated in the available space (see Fig. 10).

The floor plan is on a glass plate 9 by 12 inches, part of which is divided into blocks and scaled to represent an area

FIG. 17. When a TV demonstration is in progress, two technicians operate camera controls in mobile unit. Not seen is the technical director who operates switching.



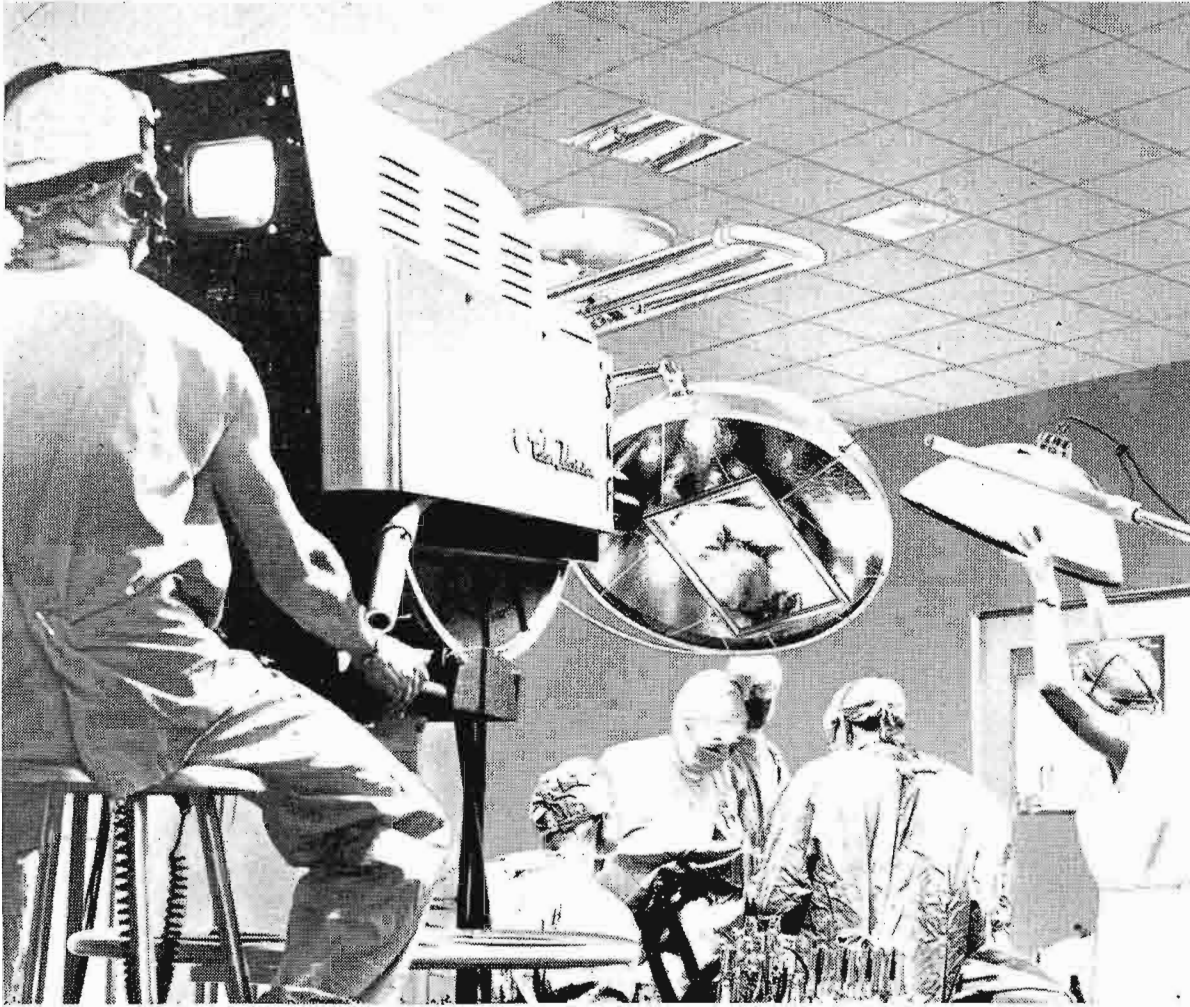

FIG. 18. Studio TV camera being used to televise operation by focusing on mirror fastened to surgical light. (This expedient serves until boom-mounted surgical camera is delivered.)

8 by 24 feet, so that on it can be blocked off the size of the room available for studio use. (The remainder of the area on the plate is for camera movement.) Scale models are available for hospital carts, chairs, demonstration tables and TV monitors; also figures of doctors, nurses and

patients. By use of these the medical doctor can readily see the scope and limitations of his presentation area. This results in rapid decisions of room choice and avoids considerable loss of time otherwise occasioned when the participants cannot readily visualize the limitations of space.

FIG. 19. Portable director's console, on wheels, contains miniature monitors fashioned from RCA 8-inch personal TV sets. Color receiver in background is used for live monitor.



Director's Console

Near the studio (or in it if large enough) is stationed the program director's console. This is a 54 by 36-inch unit, of sheet metal construction, standing 30 inches high (plus a 15-inch sloping panel). Mounted on wheels, it is easily moved about for convenient placement. The unit has been designed and built by SK&F engineers.

The console is equipped with three monitors, a microphone, intercom, speaker, clock and timer. The monitors consist of RCA 8-inch personal TV sets, the controls of which are readily reached through a small door in the top of the console. The microphone is switchable to:

1. Studio, for rehearsal talkback,
2. Live, for announcing,
3. Truck, for switching, etc., and
4. Surgery, for rehearsal talkback.

The intercom is ordinarily a universal connection to all the crew but has an isolation switch for providing the director with a private communication channel to the studio floor manager. The loud-speaker carries the program audio. The timer, equipped with start, stop and reset buttons, is used for rehearsals.

The three monitors display pictures from studio cameras one and two, and from the surgical camera in the operating room. The number three monitor on the console is switchable to permit preview of special effects. In addition, an RCA 21-inch color TV set is used for the line monitor.

Production Desk

This is a 2 by 2-foot case 36 inches high, on wheels, and designed to hold all of the small essential items required by the studio floor manager. It looks like a shipping case with a slanting top and door. When, however, the door is opened, there are revealed three large drawers and several shelves all loaded with production accessories. Slides, pointers, paper supplies and crayons are in one place. Models, cue-cards, and general accessories are in another. Lab jackets, velvet covers, masking tape are in the drawers. The slanting top provides a most convenient working desk for the studio floor manager.

Speeding Rehearsals

Production personnel at SK&F have designed a floor plan sheet that enables the studio floor manager to rapidly plan for each separate studio scene. He can plot the action, the traffic movement, and the equipment placement. This is done using a series of blocked-out floor plans printed

on 9 by 15-inch sheets (which are fastened together to make tablets). Each sheet contains three floor plans and has space for notes. A series of rubber stamps enables the floor manager to place the following items on the plan:

- Cart (or bed)
- LDT (large demonstration table)
- DT (small demonstration table)
- MD (doctor)
- P (patient)
- X-ray (X-ray presentation)

Thus each scene can be rapidly plotted as it is finalized during rehearsals.

Operating Room

A studio color camera was employed for the Kansas City surgical demonstrations since the special medical color camera on order from RCA had not yet been delivered. The camera was focused on a mirror fastened to the ceiling-mounted surgical light (see Fig. 18). The mirror was angled so that the camera picked up a view of the operating field illuminated by the light. A special small size monitor, consisting of an 8-inch RCA personal TV set mounted on a self-supporting tubular stand, gave the surgeon an eye-level view of the resultant picture.

Microwave Link

From the Kansas City General Hospital to the Municipal Auditorium, a distance of several air miles, the Southwestern Bell Telephone installed a microwave link. This consisted of a one-way link with transmitter at the hospital and receiver at the auditorium. RCA Type TTR-1 equipment, modified for color, was employed. One operator at each end was used to insure top performance.

Intercommunication

All operating positions are in touch with one another and also all personnel. The telephone company installs two audio lines to and from the hospital and auditorium for questions and answers. One private line is installed for engineering from the TV truck to the auditorium. One regular telephone business line is also installed in the truck.

Compatible Color TV

After many years of experience, SK&F has shifted from field-sequential to RCA compatible color TV equipment for its medical presentations. The change was however, not without compensation. Several disadvantages were thereby overcome, namely, rapid obsolescence of, and the inability to expand, the field-sequential equipment.

There are in addition numerous other advantages derived from the use of compatible equipment. It is possible to use the services of local broadcasters and the networks whenever desirable. The medical programs can be put on air and closed-circuit intercity loops can be arranged. Great distances can be covered and many more persons can be reached.

With compatible equipment the color TV picture projected on the screen is of larger size. It also has twice the screen brightness as heretofore. This means it will be possible to seat more people in the viewing auditorium. It also means that the doctors will get a clearer view of the presentation.

RCA Picture Projector

The new RCA TV picture projector is less bulky and much lighter than previously used equipment, hence easier to transport and sets up much faster. It will also plug into a regular 110-volt outlet since it requires only 500 watts of current, whereas the previous equipment had to have special power supply wiring in order to obtain 70 amps. The new projector will also work on 50-cycle current, with slight adjustment, and so can serve for international demonstrations.

The Crew at Home Base

The engineers design specially needed devices and do maintenance work on TV equipment, when not out on the road. They design and construct portable studio and control apparatus, amplifiers and composite cables, dual slide projection equip-

ment. Cabling is gone over, repaired where necessary, and new sections added as required. Stocks of spares are replenished. Cameras and all operating gear are serviced and readied for the next tour.

The production personnel work on programs for future shows. Models are designed and built to expedite the productions setup. Scripts are prepared. Correspondence with participants in future shows and meetings with doctors are arranged in order to formulate specific programs.

The crew travels from 20,000 to 30,000 miles (counting the planning as well as demonstration sessions) per year, while the equipment travels from 10,000 to 15,000 miles. The crew averages 130 days per year on the road.

Widespread Applications

In seven years SK&F has presented 90 programs consisting of 1138 clinics and 705 surgical procedures. Every major type of surgery and almost every type of dry clinic has been colorcast. Sixteen babies have been delivered "on air." Almost a half million doctor-visits have been made to the program, an average of 60,000 visits per year. An average of 15 medical presentations are made per year ranging from Canada to Mexico and from coast to coast. With its new equipment the SK&F-TV Unit expects to be in more demand than ever before and more doctors will benefit from the surgical and clinical demonstrations undertaken by SK&F in the behalf of the medical profession.

FIG. 20. Audiences of doctors, students and nurses throughout the nation are now viewing color pictures of live operations as SK&F makes these presentations on behalf of the medical profession.



TV PROJECTION SYSTEM FOR COLOR AND MONOCHROME DEVELOPED BY RCA

*Designed for Closed-Circuit Presentations,
System Produces Color TV Pictures for
Audiences Up to 500 People and
Provides Valuable Color Promotion
Tool for Broadcasters*

Color TV Projection System, Type TLS-50, produces large color pictures up to 4½ by 6 feet using three side-by-side Schmidt optical systems with three 2½-inch projection kinescopes.

An auditorium-size compatible color TV projection system, which produces pictures up to 4½ by 6 feet with adequate high-light brightness, has been developed for closed-circuit applications.

This compatible color TV development (TLS-50) has been scheduled for commercial production by the end of this year. Scheduled for commercial availability at the same time is a similar monochrome projection system, identical with the color TV system except that it utilizes black-and-white instead of color projection tubes. The black-and-white projection system produces pictures up to 6 by 8 feet in size.

Broadcast applications for this projection system include its use in TV stations where facilities for overflow studio audiences must be provided. The system should prove valuable to those stations actively promoting color. The color promotion may take the form of color clinics for TV servicemen, agencies and advertisers.

Two pre-production units of the TLS-50 color TV projection system have been purchased by Smith, Kline & French Laboratories, Philadelphia, Pa. pharmaceutical firm, for closed-circuit presentations of surgical and clinical demonstrations at medical society meetings. The system was first shown publicly by SK&F in September during the recent meeting of the Kansas City Southwest Clinical Society, Kansas City, Missouri. Audiences of over 500 saw the shows. SK&F also used

two TLS-50's for a week long closed-circuit color TV demonstration before the meeting of the American College of Surgeons in San Francisco.

The new auditorium-size projection system can be used for color TV clinics, academic and medical classrooms, business and sales meetings, and product shows and demonstrations. The color and monochrome projection systems are intended for use with directional screens having a gain of two-and-a-half times. With such screens, the useful seating area covers a total angular width of more than 90 degrees.

This new system has been developed to meet a need for an auditorium size color TV projection system that satisfies the size, budget and applicability requirements of the classroom and the meeting room as well as the broadcaster. Prior to this development, organizations planning color closed-circuit presentations were limited in picture size to either home color TV or color projection systems of theatre-screen size. Both the new color and monochrome projection systems represent greater economy, flexibility and effectiveness in closed-circuit presentations.

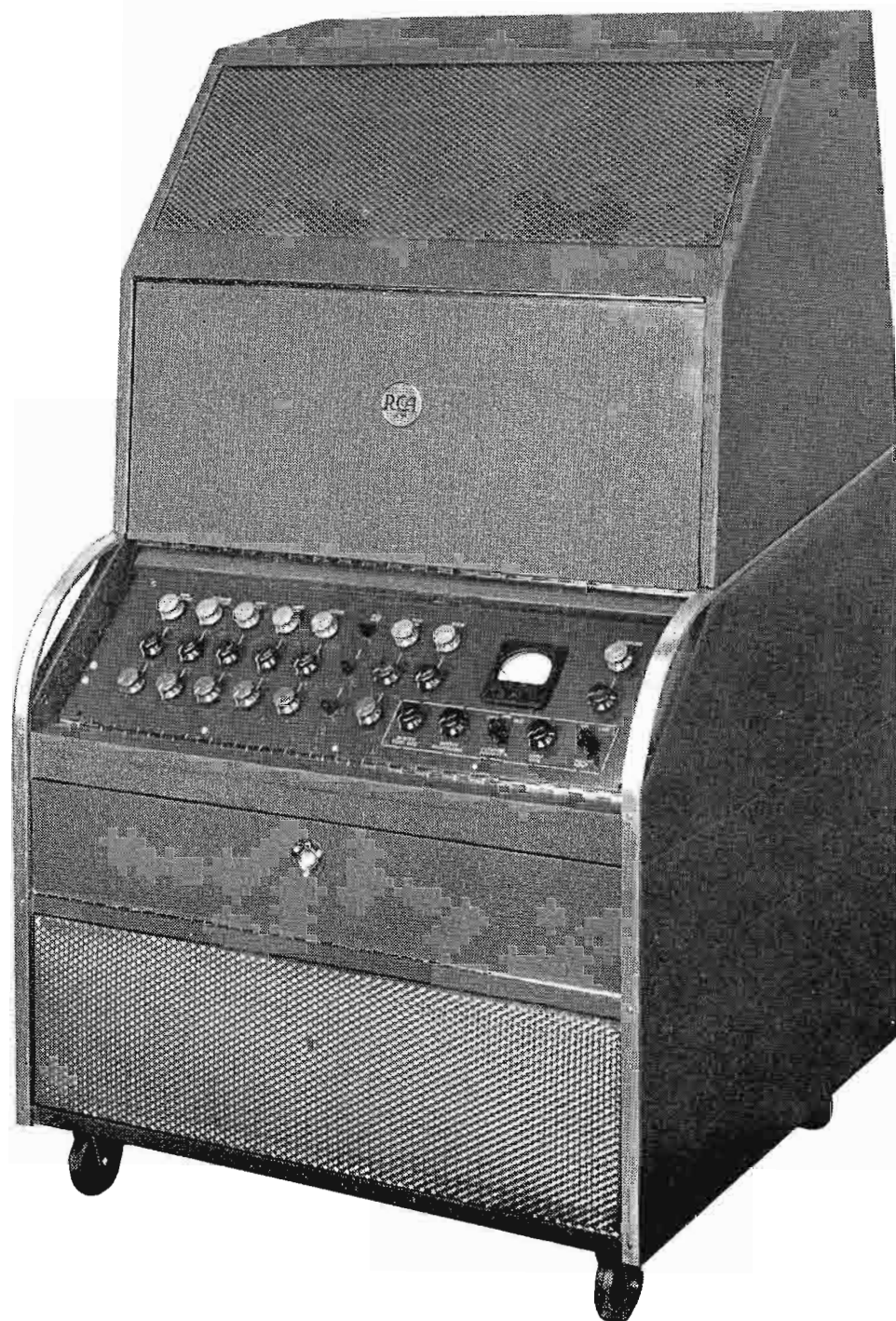

FREE BOOKLET

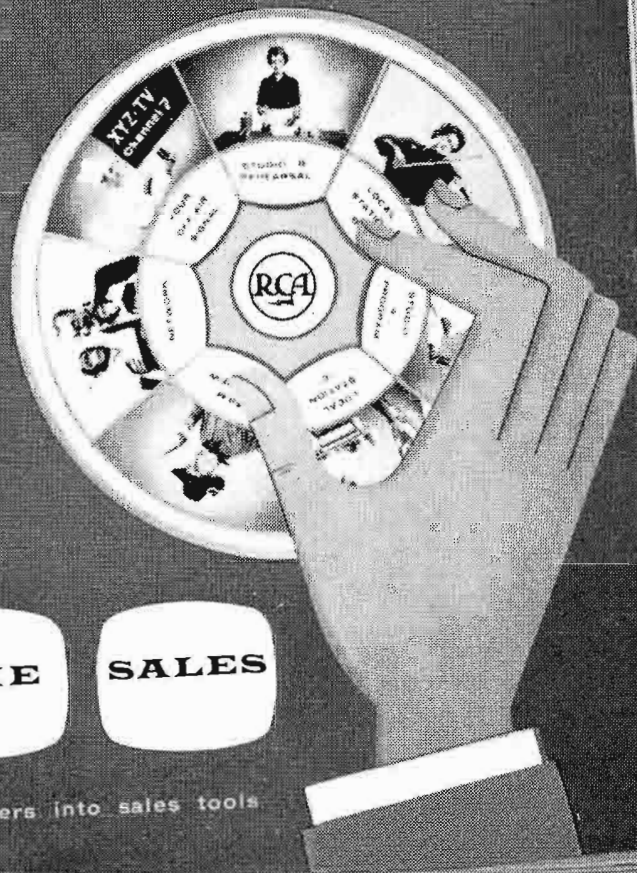

TUNE IN YOUR TIME SALES

RCA House Monitoring turns your receivers into sales tools

... TELLS HOW STATIONS CAN GIVE SERVICE THAT RATES HIGH WITH CLIENTS

"Tune in Your Time Sales" describes the benefits of the RCA House Monitoring System. It points out that with such a system the television station is better equipped for serving clients efficiently.

You can dial any local on-air signal... any studio signal wherever you happen to be in the station. What a service to sponsors this is in program planning! When a question is asked about other stations... competing programs... you're there with the proof! In special presentation in your own studio, or in viewing commercials, it's a tremendous assist to be as close to the "on-air" result as your nearest monitor.

Up to seven channels are available—tailored to your own special requirements. You can flip the switch and bring in whatever your client requires.

Fully rated for color, the RCA House Monitoring System is low in cost and easy to install and operate. Complete technical description of the equipment is included in this booklet.

Ask your Broadcast Sales Representative for a copy.



Your Off-Air Signal



Film Preview



Special Client Presentation in Your Studio



RADIO CORPORATION of AMERICA

BROADCAST AND TELEVISION EQUIPMENT

CAMDEN, N. J.

In Canada: Write
RCA VICTOR Company
Limited, Montreal

Unlimited system plus superb picture quality...make RCA best

Improved technical quality in your film programs need not require a big investment

ICONOSCOPE CONVERSION

You can start simply and build gradually, if you prefer, first by converting iconoscope film cameras to RCA vidicon film cameras. You'll get marked improvement in gray scale, tremendously increased signal-to-noise ratio, improvement in resolution, and provision for automatic black level control . . . all with a minimum of operating attention. The "snap," clarity and live effect will be immediately reflected in advertiser preference.

MONOCHROME SYSTEM EXPANDABLE TO COLOR

Or, you can start with the superior vidicon film system expandable to color. Using the RCA TP-15 universal multiplexer, color and monochrome film equipment can be completely integrated—by adding a TK-26 color film camera at any time. This new multiplexer accommodates up to four projector inputs, all of which are available to two film camera outputs.

COLOR FILM SYSTEMS

To go to color *now*, you can select from various equipment combinations which use the RCA TK-26 three-vidicon film camera. In TV stations where superb picture quality and operational simplicity count, the TK-26 is the preferred system for color film programming. It has been selected after careful comparative evaluation with other systems and found to produce finer quality film pictures in both monochrome and color. Superior results are achieved at minimum cost with maximum operational simplicity.

LIVE COLOR, TOO

It is possible to use the RCA three-vidicon film system for pickup of opaques, live commercial products and demonstrations within a limited area.

See your RCA Broadcast Representative for more details on Vidicon Film Systems. He will be glad to answer your questions. Let him help plan a film system that can start you on the road to the new and additional revenue that will come from color!

NEW STANDARDS OF QUALITY

The RCA Vidicon Film System has established a standard of film reproduction by which all other methods are judged. You can expect and get the highest quality reproduction, with protection against obsolescence for years to come. To give some idea of the wide range of system possibilities with RCA equipment we submit four diagrams, at right, from the very simplest equipment to a Dual Color Film System.

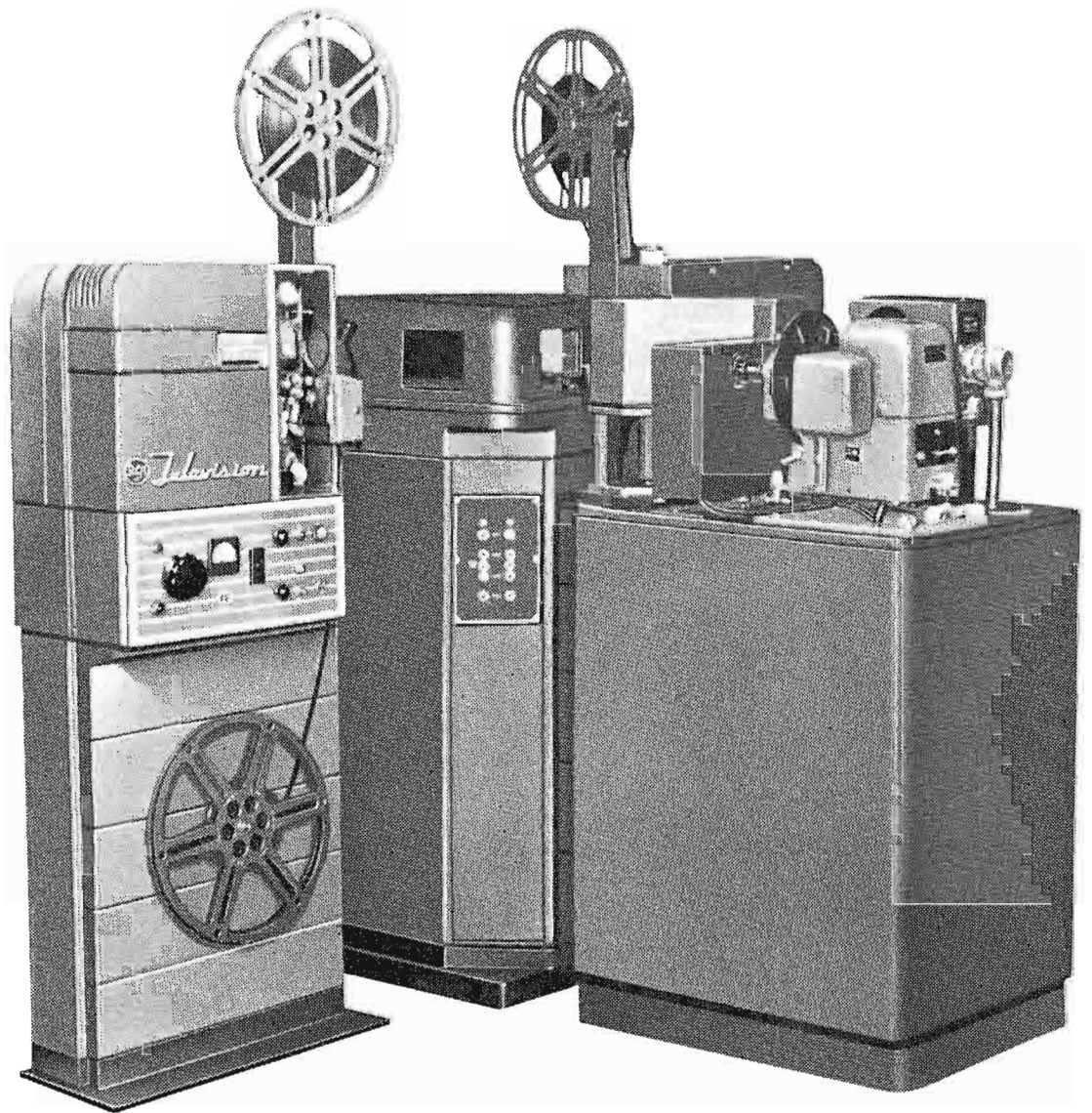

Monochrome film system
expandable to color.



RADIO CORPORATION of AMERICA
BROADCAST AND TELEVISION EQUIPMENT

CAMDEN, N.J.

possibilities . . .

buy in film equipment—monochrome and color

1. CONVERSION OF ICONOSCOPE FILM SYSTEM TO VIDICON

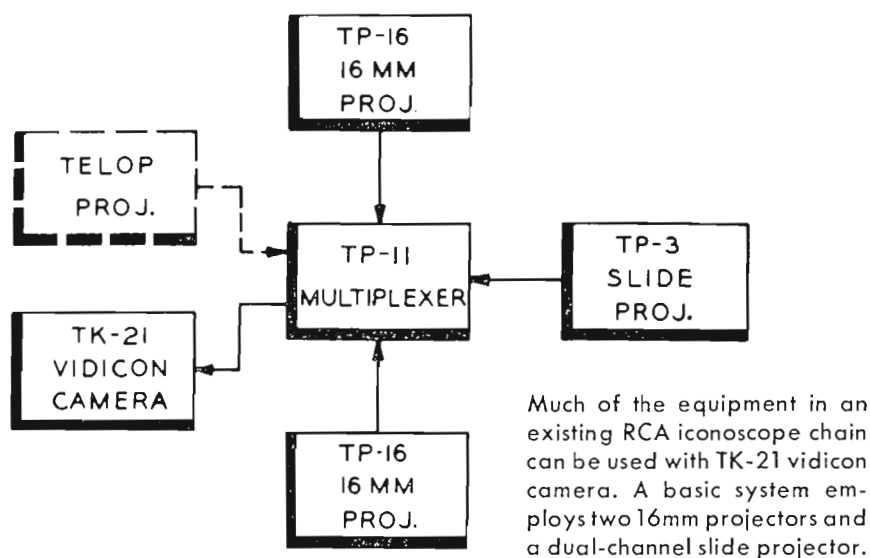

3. BASIC COLOR FILM SYSTEM

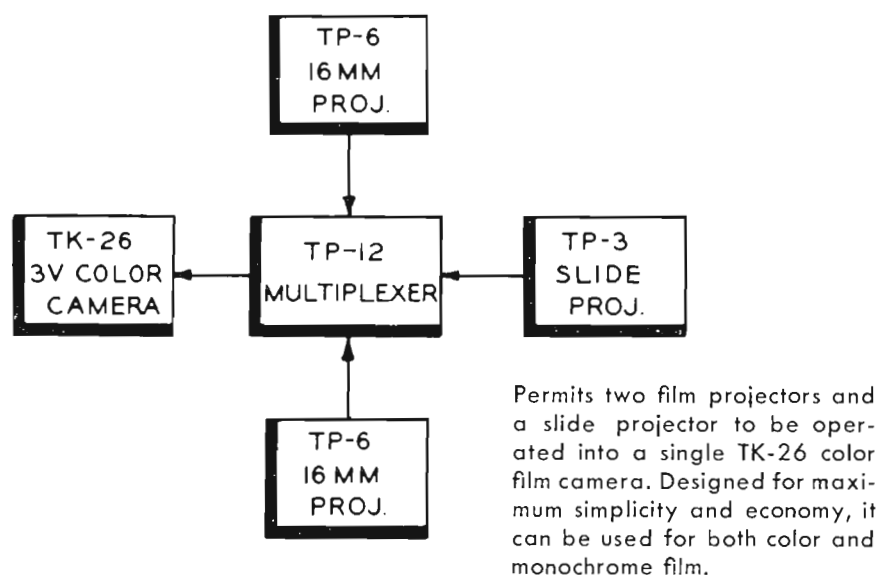

2. MONOCHROME FILM SYSTEM EXPANDABLE TO COLOR

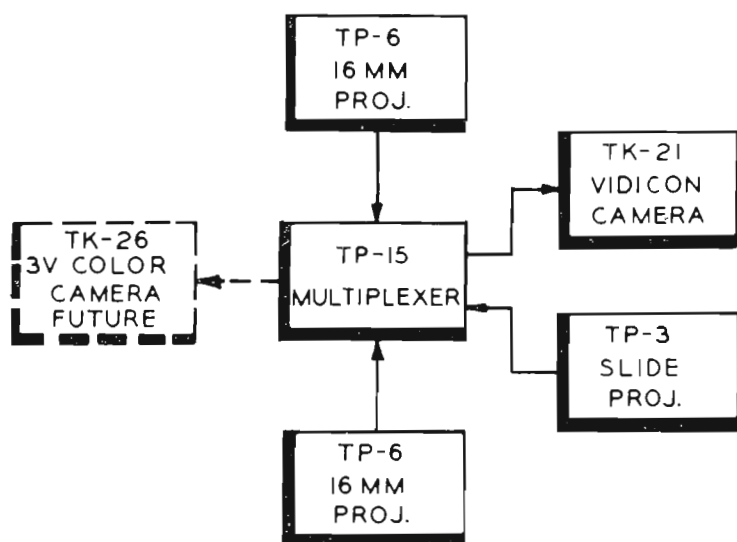

4. DUAL COLOR FILM SYSTEM

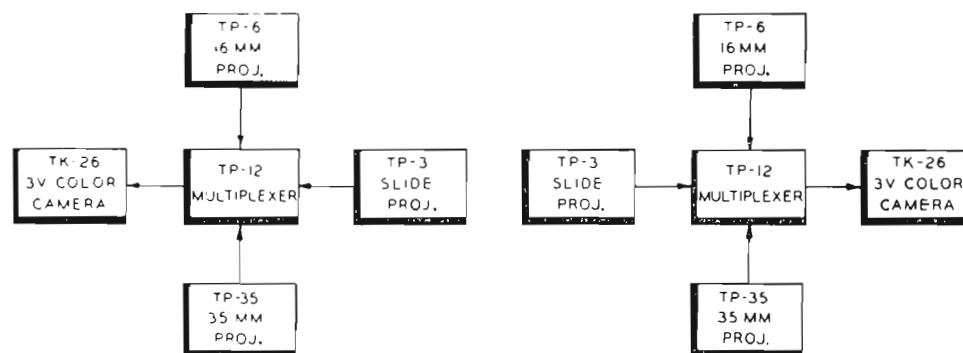

Best for color and monochrome because it uses proved-in components !

VIDICON TUBE . . . RCA development

Vidicon storage tube is outstanding from standpoint of high signal-to-noise ratio, reliability and low-cost operation. It produces a sharp lifelike picture—equally good in monochrome or color. Replacement involves minimum of equipment readjustment.

STANDARD-TYPE PROJECTORS FOR 35 and 16MM

Standard of the motion picture industry, the intermittent projector produces a beautiful steady picture. It involves none of the critical mechanical tolerances of the continuous projector for 16mm. RCA now offers the TP-6 series projector designed from the beginning for professional 16mm television use. Provides maximum video and audio quality with operating convenience and dependability. RCA neutral-density-filter light

control makes it possible to achieve satisfactory results with practically all kinds of film.

NEW TYPE TP-15 MULTIPLEXER

Provides for complete integration of color and monochrome. Offers flexibility and protection of two-camera system without the necessity of buying separate projectors for each camera. Permits preview of one program while another is on-air.

OPERATING CONVENIENCE AND SIMPLICITY

Only two simple controls are employed in "on-air" operation. Pedestal level and Master Gain. For assuring picture perfection, all controls, together with waveform and picture monitors, are located at the operating position.

WAAM-TV Gets

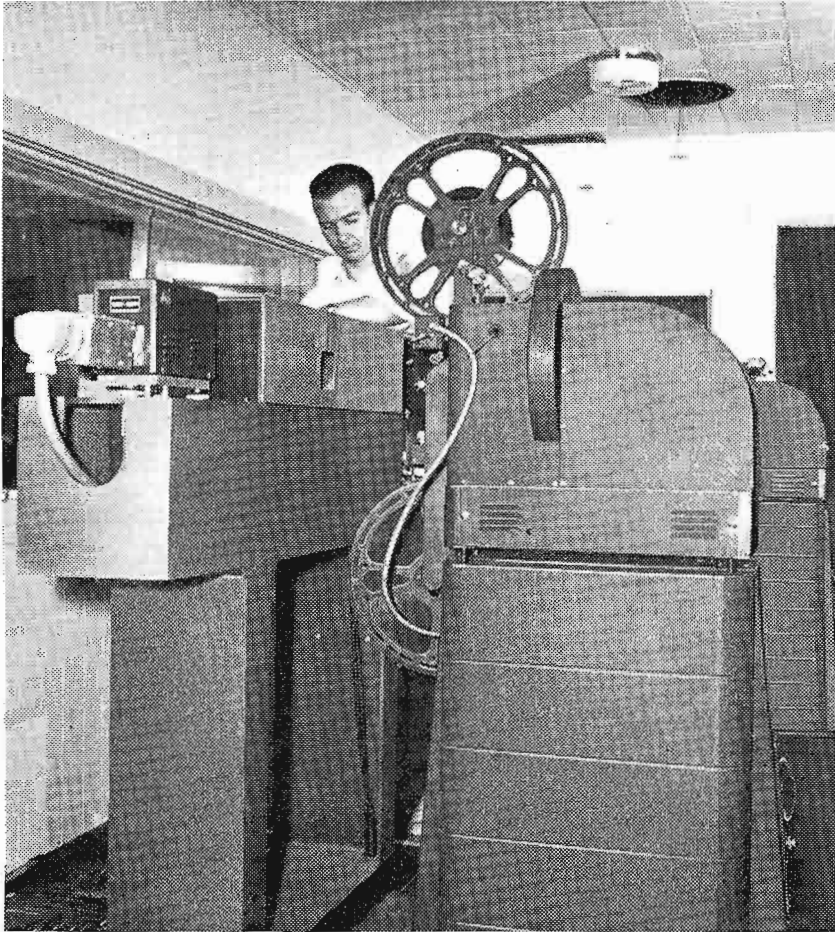

TWO FILM CHAINS MODIFIED! Picture above shows modernized WAAM-TV film projection room. The RCA TK-21 Vidicon Cameras are mounted on TP-11 Multiplexers. One TP-16 Film Projector, one 35 mm slide projector and an opaque projector are used with each camera. The two independently operated chains increase ease of operation and provide preview and auditioning facilities.



SPARE CAMERA! Simplicity and small size of RCA TK-21 make it practical to keep a third camera on hand as a spare. This allows either film chain to be quickly returned to service in emergencies and provides station clients with this assurance of continuous programming.

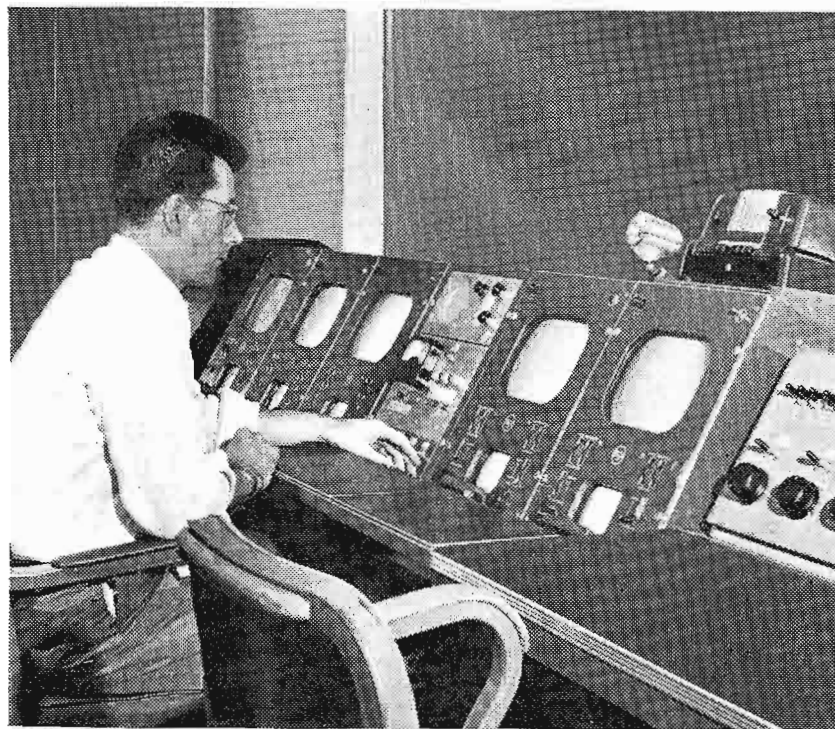

MINOR CHANGES IN CONTROL ROOM! Second and third monitors from left are the vidicon master monitors. Their housings also enclose the camera control panels. Installation was relatively simple since the station's original film monitors and housings were used. No changes in arrangement were required—vidicon control panels being substituted for control panels of the iconoscope cameras.

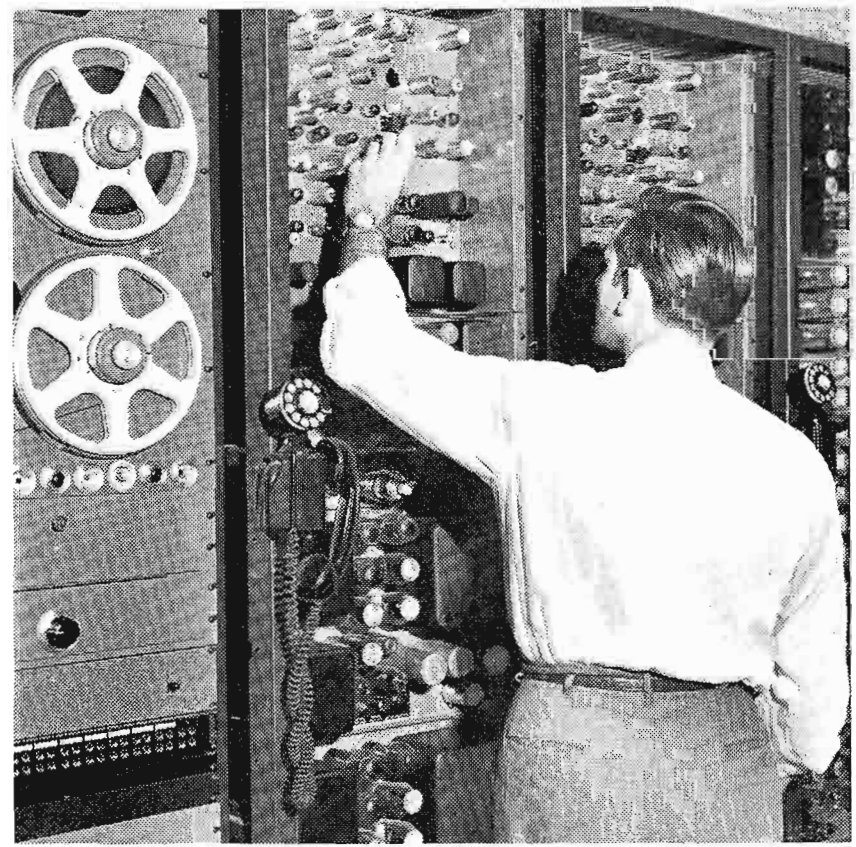

SIMPLE RACK ADDITIONS! Closeup of the two cabinet racks containing auxiliary and power equipment for the two vidicon film cameras. Only the vidicon control chassis and vidicon deflection chassis (top and next to top panels in each rack) had to be installed in each chain. Power supplies were already part of original equipment. Racks are readily accessible for setup, adjustment and maintenance.

Better Picture Quality

by Replacing Iconoscope Film Cameras with RCA Vidicon Film Cameras

WAAM-TV, Baltimore, has replaced its iconoscope film cameras with RCA Vidicon Film Cameras and is obtaining much improved pictures at lower operating cost. WAAM-TV's two iconoscope film camera chains had been in operation for over six years. During that time a number of improvements in original circuitry had been incorporated to boost iconoscope performance.

VIDICON PERFORMANCE INVESTIGATED

In their search for further improvement WAAM-TV engineers inspected one of the first RCA Vidicon chains at Camden. They immediately noted performance that surpassed the iconoscope chain in almost every respect . . . marked improvement in gray scale, tremendously increased signal-to-noise ratio, improvement in resolution, elimination of shading signals, and provision for automatic black level control.

TESTS PROVE VIDICON SUPERIORITY

Actual operating comparisons were made by WAAM-TV engineers by running several of the station's own films on both the iconoscope and vidicon chains. Says Ben Wolfe, WAAM-TV's Director of Engineering, "The reproduction from the vidicon chain was superior in each instance, with a minimum of operating effort." As a result of this demonstration WAAM-TV decided to modernize with vidicons.

STATION SAVINGS ON CONVERSION

WAAM-TV's purchase and installation of two RCA Vidicon chains shows how operating cost can be reduced by modernization of existing equipment. The economy afforded by using existing iconoscope auxiliary equipment — master monitors, console housings and power supplies — permitted expanded station versatility through the use of two multiplexers with two vidicon chains. Since no changes in arrangement were required in the master control room (vidicon remote control panels were merely substituted for the control panels of the iconoscope cameras) actual installation was simplified, allowing greater ease of operation.

AGENCIES APPLAUD IMPROVED QUALITY

The quality of WAAM-TV's film reproduction has received hearty endorsement from advertising agencies who appreciate its sales effectiveness. Their comments have stressed the "snap," clarity and live effect noticeable in WAAM-TV film presentations. This praise, from men who make it their business to recognize top performance, is the final proof of "RCA Vidicon quality."

You, too, can transform film shows and commercials that are just "getting by" into sparkling, life-like hits! Do it with an RCA Vidicon Film Camera System . . . conveniently and economically. Ask your RCA Broadcast Sales Representative for complete details. In Canada, write RCA Victor Ltd., Montreal.



RADIO CORPORATION of AMERICA

BROADCAST AND TELEVISION EQUIPMENT

CAMDEN, N. J.

COLOR



RCA LIVE COLOR CAMERA

**"ALL-IN-ONE"
PROCESSING
AMPLIFIER**

**SPACE SAVING
EQUIPMENT**

All-electronic unit provides identical control equipment for both live and film camera chains.

Only 100 inches of rack space required for all equipments necessary to operate camera chain. With monitors and processing amplifier at the console, only $\frac{3}{4}$ of a rack needed for efficient complete installation.

**NEW
POWER
SUPPLY**

**CENTRALIZED
CONTROLS**

Occupies only $\frac{1}{2}$ space of former d-c power supplies . . . high efficiency plus high output . . . 1500 ma.

Minimize setup time . . . only two controls in "on-air" operation. In addition, over-all stability, peak camera performance and picture quality are assured.

means business!

STATIONS NOW USING LIVE COLOR TO BUILD HIGH SPONSOR INTEREST

Equipped with RCA Live Color Camera Equipment, alert station managements are trail-blazing along the new frontiers of television...adding brilliant dimensions to programming techniques, transforming commercial products into thrilling reality. These progressive television stations are using local color originations to build prestige and stimulate sponsor interest.

LIVE COLOR STATIONS

KHQ, Spokane	WBAL, Baltimore	WJAC, Johnstown
KJEO, Fresno	WBEN, Buffalo	WKY, Okla. City
KMTV, Omaha	WBTV, Charlotte	WNBQ, Chicago
KOMO, Seattle	WCBS, New York	WOAI, San Antonio
KRCA, Los Angeles	WCCO, Minneapolis	WRCA, New York
KRON, San Francisco	WDSU, New Orleans	WSAZ, Huntington
KTLA, Los Angeles	WFBM, Indianapolis	WTMJ, Milwaukee
WBAP, Fort Worth	WGN, Chicago	WTVJ, Miami
WFIL, Philadelphia	WRCV, Philadelphia	WCAU, Philadelphia
WBRE, Wilkes-Barre	KARD, Wichita	WGAL, Lancaster
KCMO, Kansas City	WJBK, Detroit	KGW, Portland

Local studio originations, and live commercials in color are making sponsors sit up and take notice. Your station can spark the same type of advertiser interest in production of live color with RCA's color camera equipment! For complete technical information call your RCA Broadcast Sales Representative. In Canada write RCA VICTOR Company Limited, Montreal.



RCA PIONEERED AND DEVELOPED COMPATIBLE COLOR TELEVISION

RADIO CORPORATION of AMERICA

BROADCAST AND TELEVISION EQUIPMENT

CAMDEN, N. J.

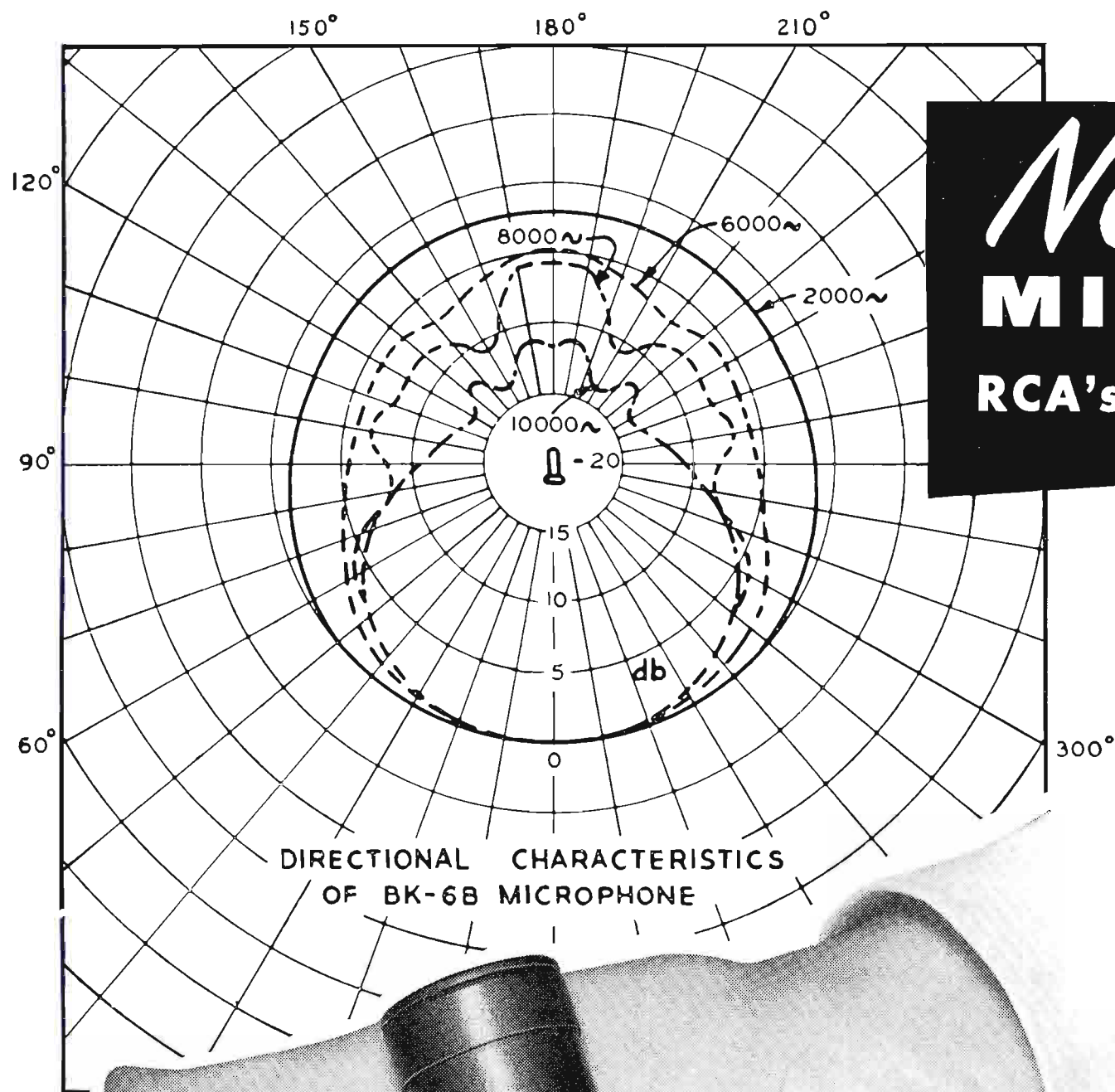

New PERSONAL MICROPHONE

RCA's BK-6B Miniature Mike

- **Half the size (by volume) of the BK-6A!**
- **Excellent speech balance when talking "Off Mike!"**
- **Wide range Frequency Response!**

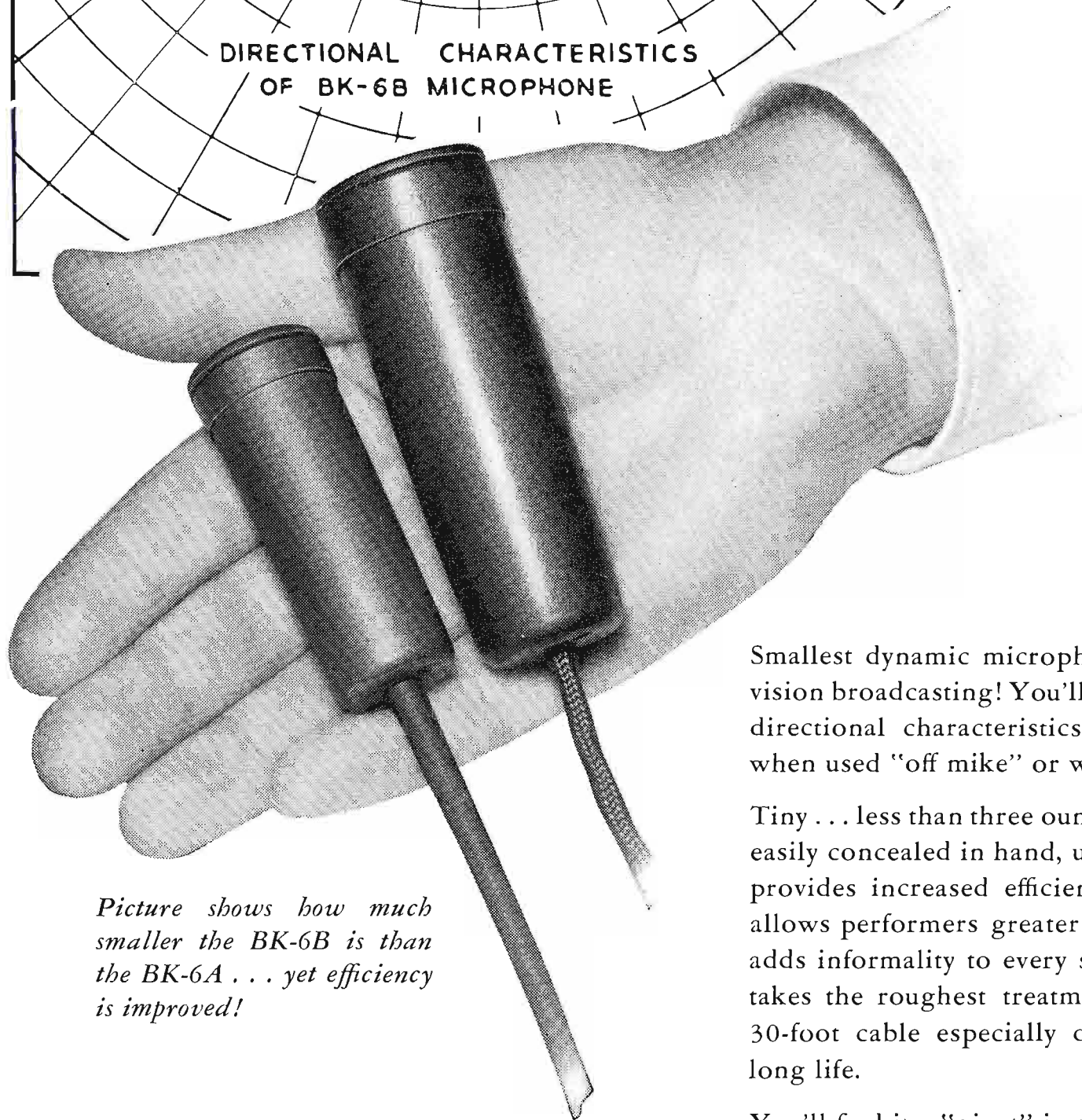

Picture shows how much smaller the BK-6B is than the BK-6A . . . yet efficiency is improved!

Smallest dynamic microphone ever developed for radio and television broadcasting! You'll be amazed by its frequency response and directional characteristics that provide superior speech balance when used "off mike" or worn on the person.

Tiny . . . less than three ounces in weight, this new miniature mike is easily concealed in hand, under necktie, or corsage. Versatile . . . it provides increased efficiency to difficult walk-around operations, allows performers greater flexibility and freedom of movement . . . adds informality to every such production. Tough . . . the BK-6B takes the roughest treatment in stride, is furnished with flexible 30-foot cable especially designed for ease of manipulation and long life.

You'll find it a "giant" in performance for a wide variety of broadcast applications. Ask your RCA Broadcast Representative for complete information. In Canada, write RCA VICTOR Company Ltd., Montreal.



RADIO CORPORATION of AMERICA

BROADCAST AND TELEVISION EQUIPMENT

CAMDEN, N. J.

RCA Time-proved Tube Designs...for longer service

**48,044
HOURS
ON-AIR**

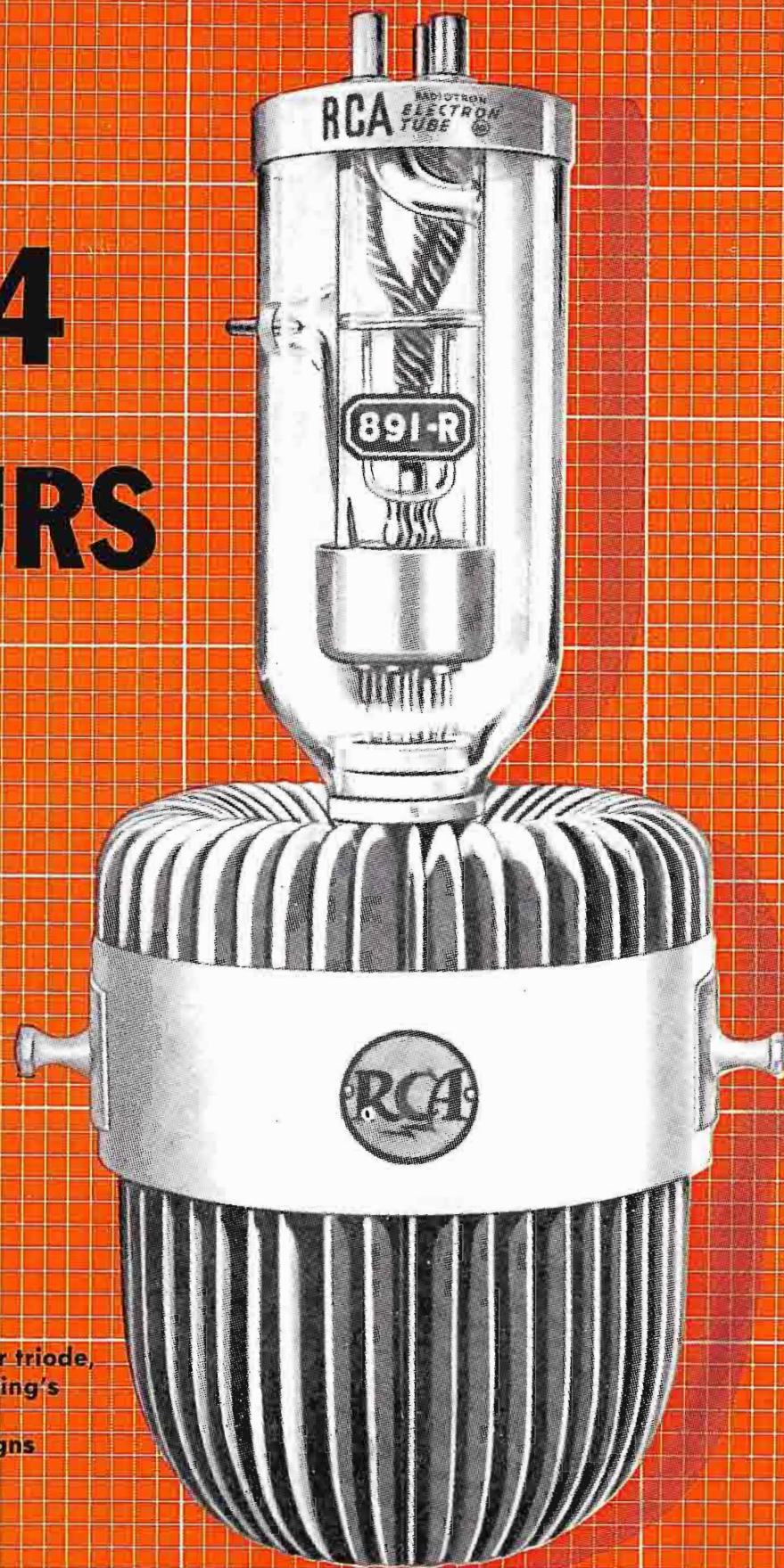

**...in
11 years
of operation**

RCA-891-R power triode,
one of broadcasting's
first forced-air-
cooled tube designs
—still a favorite.

The remarkable endurance of RCA Power Tubes is due in great measure to "proved-in" designs—that have withstood and passed the "shake-down" tests of practical transmitter operation for years and years. Take RCA's famous forced-air-cooled designs—like the RCA-891-R at WOI. Says WOI's Chief Engineer, Keith K. Ketcham:

"In April of 1952 we removed from our RCA 5DX 5-kw transmitter, an RCA-891-R modulator tube...which was purchased by WOI in September 1939... The total number of hours in use chalked up by this tube amounted to 48,044.6—which amounts to approximately 11½ YEARS OF SERVICE IN OUR TRANSMITTER!"

RCA application-proved power-tube designs are paying off for broadcast stations like WOI every day—in assuring greater reliability of equipment operation—in reducing tube cost per hour of operation! Your RCA Tube Distributor is ready to handle your call for RCA Tubes of all types promptly—for virtually every need and operation in a broadcast station.

HOW TO GET MORE HOURS FROM AN RCA-891-R

- Reduce filament voltage to the minimum to give required output at acceptable distortion level—then increase by the amount required to compensate for line-voltage regulation.
- Keep air-cooling system clean—to prevent tube and circuit damage from overheating.
- When handling tube, lift it by the handles to avoid mechanical damage: Don't bump glass envelope or grid arm.
- Operate spare tubes periodically.
- Operate RCA-891-R within RCA ratings. Always follow the instructions packed with each tube.



TUBES FOR BROADCASTING
RADIO CORPORATION OF AMERICA • HARRISON, N. J.



See Color every night—even a child can tune it. (Shown) The Aldrich (21CS781) in limed oak grained finish. \$495.

“LIVING COLOR” AT \$495 IS NOW BEST TV BUY—IT’S LIKE 2 SETS IN 1

New RCA Victor Big Color is the TV for thrifty families. Now you can enjoy Color plus black-and-white in one TV set!

Here is double-value Color TV at the lowest price in history. Now you and your family will see every program *exactly* as it is broadcast. The big Color shows in breathtaking “Living Color”—all regular programs in sharp, clear black-and-white.

You see them easily with new “Color-Quick” tuning—so simple a child can do it. Turn two knobs and the screen blossoms out in Color.

You have your choice of 10 Big Color models—from table model to full-door console in contemporary or traditional styling.

See “Living Color” with your own eyes at your RCA Victor dealer’s soon. Ask him about easy budget terms on any Big Color set—your present TV may even cover the down payment!

Manufacturer’s nationally advertised VHF list price shown subject to change. UHF optional, extra. **At your service:** RCA Victor Factory Service Contracts from \$39.95 (90 days).

RCA VICTOR TRADE MARK  RADIO CORPORATION OF AMERICA

RCA PIONEERED AND DEVELOPED COMPATIBLE COLOR TV

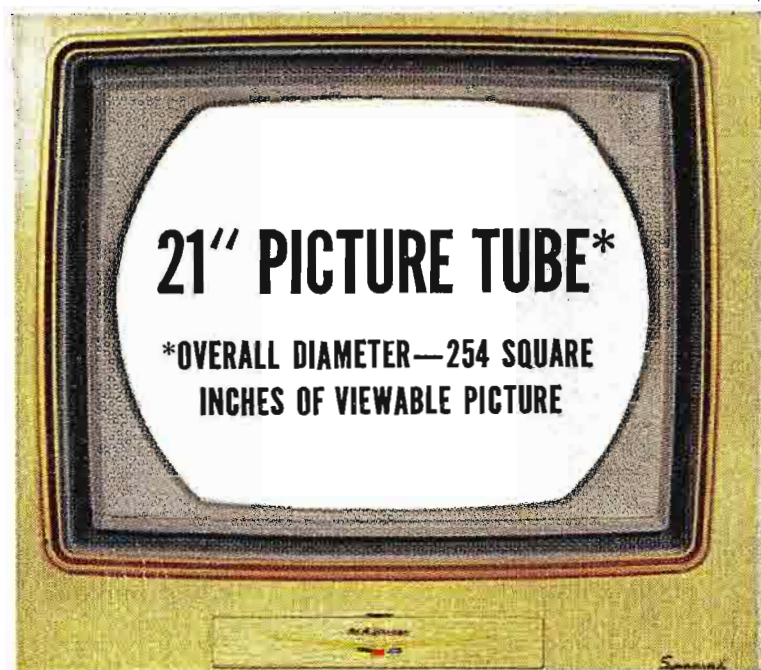

Big as life. Even the lowest priced RCA Victor Big Color set gives a huge 254 square inches of viewable picture—crisp and clear in black-and-white or Color.



All the colors of life. RCA Victor Big Color TV gives Color so natural, so alive—you have to see it to believe it. It’s a completely new experience in home entertainment.



Practical and dependable. Big Color TV service is low-cost—RCA Factory Service Contracts are available in most areas, but only to owners of RCA Victor TV sets.



Like 2 sets in 1 because it’s RCA Victor *Compatible* Color. Color shows in Color—all others in black-and-white. This is today’s common-sense investment in TV.